

SAFETY

Ensure that you read and understand these instructions **BEFORE** operating the equipment. Please pay particular attention to the Safety Warnings.

WARNINGS

1. The Searchline Excel gas detector is certified for and intended for use in potentially hazardous areas. Install and use the Searchline Excel gas detector in accordance with the latest regulations.
2. For installations in the UK, the Code of Practice SELECTION, INSTALLATION AND MAINTENANCE OF ELECTRICAL APPARATUS FOR USE IN POTENTIALLY EXPLOSIVE ATMOSPHERES should be strictly observed. General recommendations are given in BS 5345: Part 1:1989. Specific requirements for flameproof (Type 'd'), intrinsically safe (Type 'I') and increased safety (type 'e') protection are given in BS 5345: Part 3: 1979, BS 5345: Part 4:1977 and BS 5345: Part 6:1978 respectively. Consideration should also be given to BS EN 60079-14. Refer to BS 6959:1988 in the UK or the appropriate local or national regulations.
3. For installations in North America, the national Electrical Code (NFPA 70 - 1990) or later issues should be strictly observed.
4. Elsewhere, the appropriate local or national regulations should be used.
5. The Searchline Excel gas detector must be properly earthed to protect against electrical shock and minimise electrical interference. For electrical installation design considerations refer to Section 3.
6. Operators must be fully aware of the action to be taken if the gas concentration exceeds an alarm level.
7. Dismantling or repair of equipment should be carried out in the safe area only.
8. Test gases may be toxic and/or combustible. Refer to Material Safety Sheets for appropriate warnings.
9. Do not drill holes in any housing as this will invalidate the explosion protection.
10. In order to maintain electrical safety, the unit must not be operated in atmospheres with more than 21% oxygen.
11. Ensure that the bolts which secure flameproof enclosures are fully tightened. The securing bolts used are made from a special certified grade of steel. Only bolts supplied by Zellweger Analytics should be fitted for this purpose.
12. Do not open the enclosure in the presence of an explosive atmosphere.
13. The transmitter unit contains high voltages when operational. These are discharged when the unit is removed from its enclosure.
14. The conduit and cable glands fitted to Searchline Excel should not be modified. If, however, it becomes necessary to make modifications they must comply with the relevant national Codes of Practice.

SAFETY

CAUTIONS

1. Use only approved parts and accessories with the Searchline Excel gas detector.
2. To maintain safety standards, commissioning and regular maintenance of the Searchline Excel gas detector should be performed by qualified personnel.

IMPORTANT NOTICES

1. Zellweger Analytics Limited can take no responsibility for installation and/or use of its equipment if this is not done in accordance with the appropriate issue and/or amendment of the manual.
2. The user of this manual should ensure that it is appropriate in all details to the exact equipment to be installed and/or operated. If in doubt, the user should contact Zellweger Analytics Limited for advice.
3. Effect of explosive atmosphere on materials.

Searchline Excel is made from materials which exhibit good resistance to corrosive and solvative substances. The Exd enclosures are made from 316 stainless steel and the explosion protected windows are made from toughened soda lime glass. Zellweger Analytics are not aware of any significant effects of explosive atmospheres upon these materials. Contact Zellweger Analytics or one of their agents for specific queries.

Zellweger Analytics Limited reserve the right to change or revise the information supplied in this document without notice and without obligation to notify any person or organisation of such revision or change.

If further details are required that do not appear in this manual, contact Zellweger Analytics Limited or one of their agents.

HELP US TO HELP YOU

Every effort has been made to ensure the accuracy in the contents of our documents, however, Zellweger Analytics Limited can assume no responsibility for any errors or omissions in our documents or their consequences. Zellweger Analytics Limited would greatly appreciate being informed of any errors or omissions that may be found in our documents. To this end we include the following form for you to photocopy, complete and return to us so that we may take the appropriate action.

<p>To: Marketing Communications Zellweger Analytics Limited Hatch Pond House 4 Stinsford Road Nuffield Estate POOLE. Dorset BH17 0RZ United Kingdom</p> <p>Tel.: +44 (0) 1202 676161 Fax.: +44 (0) 1202 678011 E-mail : sales@zelana.co.uk</p>	<p>From: Address:</p> <p>Tel.: Fax.: E-mail:</p>
--	--

I suggest the following corrections/changes be made to:

Marked up copies attached (as appropriate): Yes / No

Please inform me of the outcome of this change: Yes / No

For Marketing Communications, Zellweger Analytics Limited:

Actioned By: Date:

Response: Date:

CONTENTS

SAFETY	2
HELP US TO HELP YOU	4
1. INTRODUCTION	7
2. OVERVIEW	9
2.1 Introduction	9
2.2 Transmitter	10
2.3 Receiver	11
2.4 Adjustable Mountings	13
3. INSTALLATION AND OPERATION	14
3.1 Introduction	14
3.2 Siting and Mounting	15
3.3 Electrical connections	19
3.4 Power supply	24
3.5 Unpacking	25
3.6 Installation procedure	28
3.7 Alignment and commissioning	34
3.8 System Controller calibration	49
3.9 Installation Checks/Tests	50
4. CROSS-DUCT EXCEL	57
4.1 Introduction	57
4.2 Gas Detector Description	57
4.3 Installation and Operation	58
4.4 Installation Procedure	61
4.5 Electrical Installation	65
4.6 Initialising the Excel Gas Detector	68
4.7 Maintenance	70
4.8 Problem Solving	72
5. MAINTENANCE	73
5.1 Inspection and Cleaning	73
5.2 Functional Checking	73
5.3 Calibration Check using the Gassing Cell	74
5.4 Display Gas Reading	75
5.5 Alignment Telescope	76
5.6 Operational Maintenance (FM)	76

CONTENTS

6. PROBLEM SOLVING	77
7. SPECIFICATIONS	82
7.1 System	82
7.2 Detectable gases	83
8. CERTIFICATION	84
8.1 General	84
8.2 CENELEC	85
8.3 UL	91
8.4 CSA/FM	96
APPENDIX A - HANDHELD INTERROGATOR	100
A.1 Introduction	100
A.2 Overview	100
A.3 Connection to System	101
A.4 Basic User Tasks	102
A.5 Menus	103
A.6 Problem Solving	116
APPENDIX B - GLOSSARY	117
B.1 Terminology	117
B.2 Measurement Units	117
B.3 Abbreviations	118
APPENDIX C - ACCESSORIES & SPARE PARTS	120
C.1 System Units	120
C.2 General	120

1. INTRODUCTION

Searchline Excel is a hydrocarbon gas detection system that is available in two versions:

- **Searchline Excel Open-Path Gas Detector**
- **Searchline Excel Cross-Duct Gas Detector**

Searchline Excel Open-Path Gas Detector (OPGD) consists of a Transmitter unit that sends an infrared beam to a Receiver unit up to 200 metres away, and can be located where a flammable hydrocarbon gas cloud is likely to occur.

The Cross-Duct version of Searchline Excel is used where the path length is less than 5 metres, for applications such as air intake ducts. Most of the installation and operating instructions for the Open-Path Excel apply to the Cross-Duct Excel, but see **Chapter 4** for specific information about the Cross-Duct version.

Both types of gas detector operate on the principle of infrared (IR) absorption. Gases absorb light at specific wavelengths depending on their molecular composition. Hydrocarbon gases absorb in the infrared region of the spectrum. If a cloud of hydrocarbon gas is present, part of the infrared light is absorbed by the gas, causing a reduction in the signal received that is proportional to the amount of gas in the beam.

The Searchline Excel Transmitter unit produces the infrared light, and the Receiver unit features optical detectors and signal processing electronics. Each unit is housed in a robust stainless steel housing. The Receiver produces a 4 - 20mA analogue output equivalent to 0 - 5 LEL.m (Lower Explosive Limit metres) of gas.

NOTE: THE INFRARED BEAM IS INVISIBLE AND EYE SAFE.

Searchline Excel is designed for use in the most demanding environments/applications and provides a sensitive, fast and reliable response. The sophisticated open-path technology provides immunity to sunlight and minimises the effects of environmental factors such as rain, fog, ice, snow and condensation.

The Transmitter and Receiver units incorporate heated optics designed to minimise the build up of humidity, condensation, snow or ice on the glass windows, that could obscure the optics in extreme conditions.

The system is microprocessor controlled with integral self-diagnostics and fault finding facilities.

Local communication between an operator/technician and the gas detector system is made via an associated Handheld Interrogator that uses the Receiver's inbuilt RS485 serial link. The interrogator provides the user with a menu-style interface to select and invoke commands for commissioning and configuring the system, and for viewing the system state and measurements.

The interrogator is connected to the Receiver via one of Zellweger Analytics' DVC100/DX100/DX100 (M) types of Termination Unit, or via other types of junction box using the optional SHC Protection Device. The DVC100 and DX100 are passive junction boxes whereas the DX100 (M) features an active digital interface that allows a remotely located control centre to monitor the gas detector's signal output and perform basic commands using the Modbus Remote Terminal Unit (RTU) protocol over an RS485 link.

1. INTRODUCTION

This handbook consists of the following parts:

- **Chapter 1** **Introduction**
- **Chapter 2** **System Description**
- **Chapter 3** **Installation And Operation**
- **Chapter 4** **Cross-Duct Excel**
- **Chapter 5** **Maintenance**
- **Chapter 6** **Problem Solving**
- **Chapter 7** **Specifications**
- **Chapter 8** **Certification**
- **Appendix A** **Handheld Interrogator**
- **Appendix B** **Glossary**
- **Appendix C** **Accessories & Spare Parts**

Information notices

The types of information notices used throughout this handbook are as follows:



WARNING

Indicates hazardous or unsafe practice that could result in severe injury or death to personnel.

Caution: *Indicates hazardous or unsafe practice which could result in minor injury to personnel, or product or property damage.*

Note: *Provides useful/helpful/additional information.*

If more information beyond the scope of this technical handbook is required please contact Zellweger Analytics.

Associated Documents

Searchline Excel Open-Path Infrared Gas Detector
Basic Installation Guide

Part No: 2104M0510

Searchline Excel Cross-Duct Infrared Gas Detector
Basic Installation Guide

Part No: 2104M0511

DX100 Series Termination Units Technical Handbook

Part No: 2104M0701

2. OVERVIEW

2.1 INTRODUCTION

Each type of Searchline Excel gas detector consists of two units, a Transmitter and a Receiver. This separate Transmitter/Receiver configuration provides the most reliable basis for open path gas detection.

There are no transceiver units or retro-panels available for the Searchline Excel, except for the Cross-Duct version, which is only for use between 0.5 and 5 metres path length. For a description of Cross-Duct Excel, see **Chapter 4**.

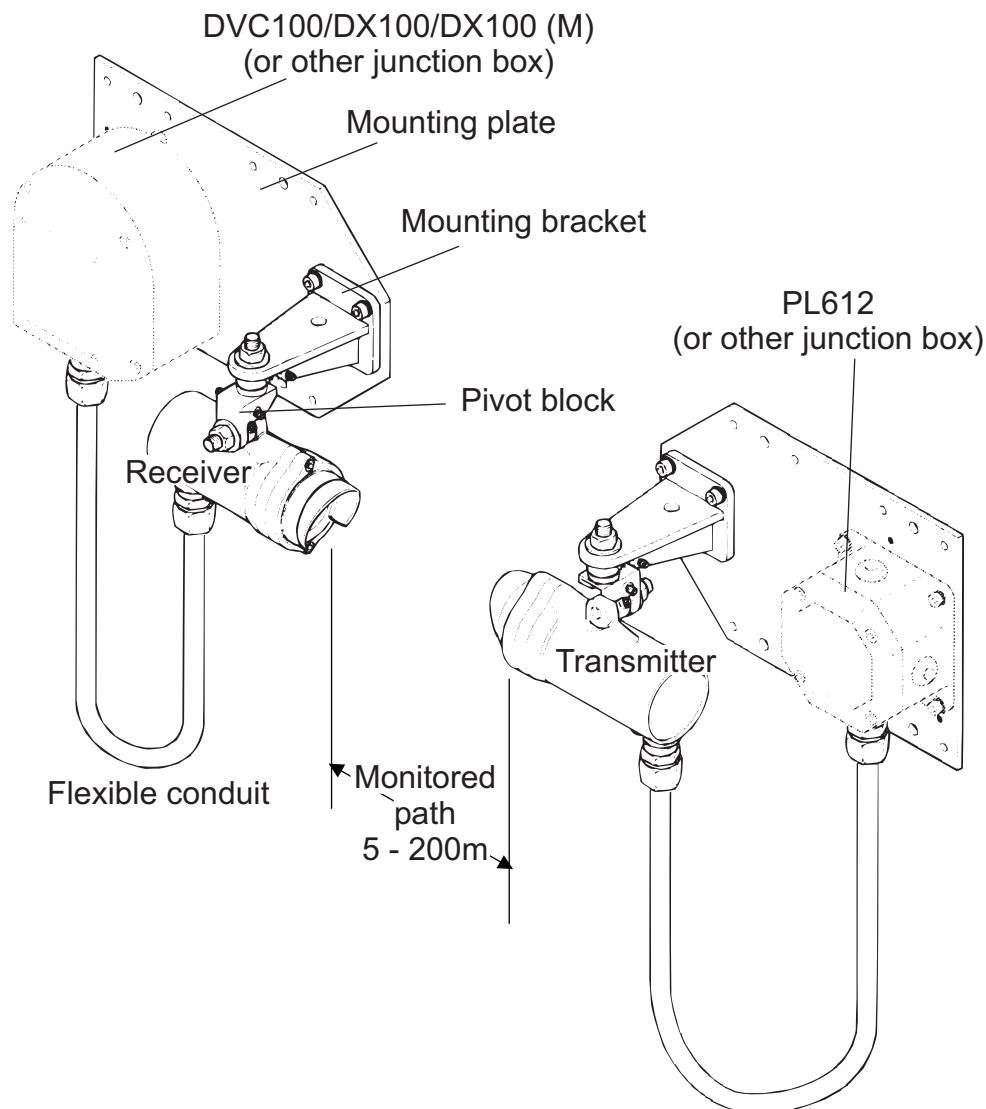

2. OVERVIEW

There are five ranges of Searchline Excel gas detector. These are:

Open-Path	Short Range	5 — 40m	(15ft — 130ft)
	Medium Range	20 — 120m	(65ft — 390ft)
	Long Range	120 — 200m	(390ft — 650ft)
Cross-Duct	Short Range:	0.5 — 2.5m	(20in — 8ft)
	Long Range:	2.5 — 5m	(8ft — 15ft)

See **Chapter 4** for details of the Cross-Duct Excel.

When designing an installation for Searchline Excel it is important that the correct range of the gas detector for each path to be monitored is selected and specified.

Note: In order to avoid the problems associated with gas detectors being used beyond their specified ranges or when incorrectly aligned, an Instrument Assisted Alignment (IAA) procedure for Searchline Excel checks for correct gas detector type, operating range and signal levels before allowing the gas detector to activate.

The Transmitter and Receiver are each mounted upon robust, adjustable mounting brackets. These brackets bolt to a mounting plate, which is designed to accommodate a variety of junction boxes, accessories and mechanical mounting configurations. The small size and flexibility of Searchline Excel and its mounting arrangements are intended to make correct installation design as simple as possible. Installation details are given in **Chapter 3**.

2.2 TRANSMITTER

The Searchline Excel Transmitter produces an intense, collimated infrared beam which is produced by a Xenon arc flashlamp.

The flashlamp's infrared output is collimated using mirrors which enables a more uniform beam (no chromatic aberrations) to be produced and hence reduces alignment sensitivity. In order to prevent annoying visible flashes, the visible emissions from the flashlamp are blocked by a filter.

The Transmitter's flashlamp is pulsed at precisely 4Hz, each pulse lasting for approximately one microsecond. The precise timing and extremely short duration of these pulses give the Transmitter a very distinctive signature. This distinctive signature makes it easy for the Receiver to distinguish Searchline Excel Transmitter pulses from both natural and artificial sources of infrared radiation.

NOTE: THE INFRARED BEAM IS INVISIBLE AND EYE SAFE.

The medium and long range Transmitters contain a higher power flashlamp and larger optics than the standard short range unit. The resulting infrared beam is many times brighter which allows for a considerable increase in operating range.

2. OVERVIEW

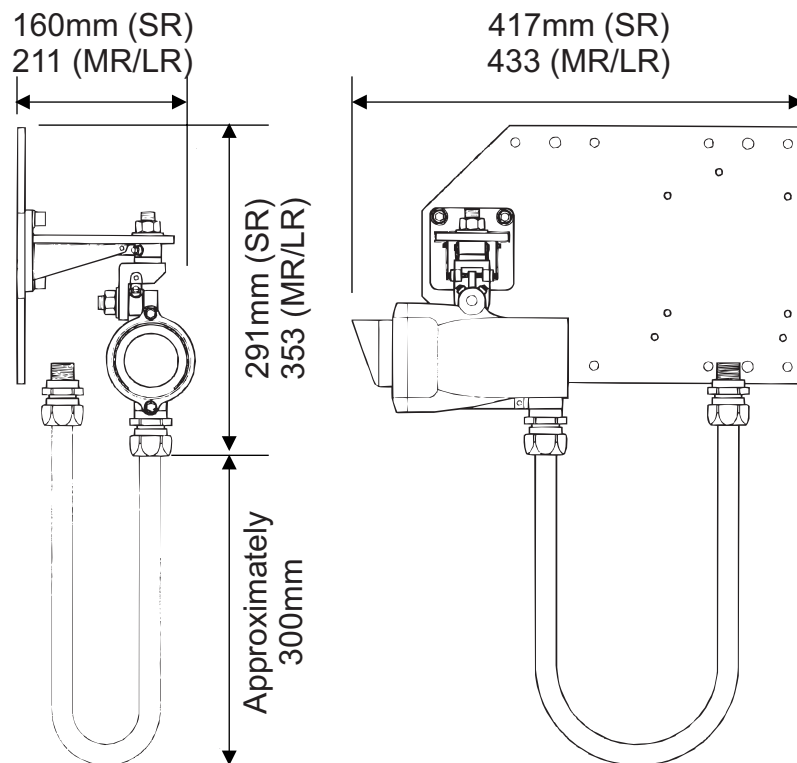

The Transmitter window is heated to minimise condensation, frosting and the build up of snow. During particularly cold operating conditions, the heating of the Transmitter window is increased to turbo levels. The turbo mode can be disabled if not required.

Electrical connections to the Transmitter are made via wires which run through the protective, flexible conduit. There are three Transmitter wires, red (+24V), black (0V) and green/yellow (GND).

2.3 RECEIVER

The Searchline Excel Receiver collects infrared radiation from the Transmitter and performs measurements to enable hydrocarbon gases in the beam path to be detected.

Infrared radiation is collected by a single, silicon lens, which is common to both the sample and reference measurement channels. This radiation is divided by a beamsplitter and fed to two filtered detectors, sample and reference.

The sample detector input is filtered at wavelengths where strong infrared absorption is exhibited by the target gas. The reference detector input is filtered at nearby wavelengths, where strong infrared absorption is **not** exhibited by the target gas. By calculating the ratio of the sample to reference signal it is possible to measure the quantity of gas in the beam, whilst compensating for the effects of rain, fog, dirt etc.

2. OVERVIEW

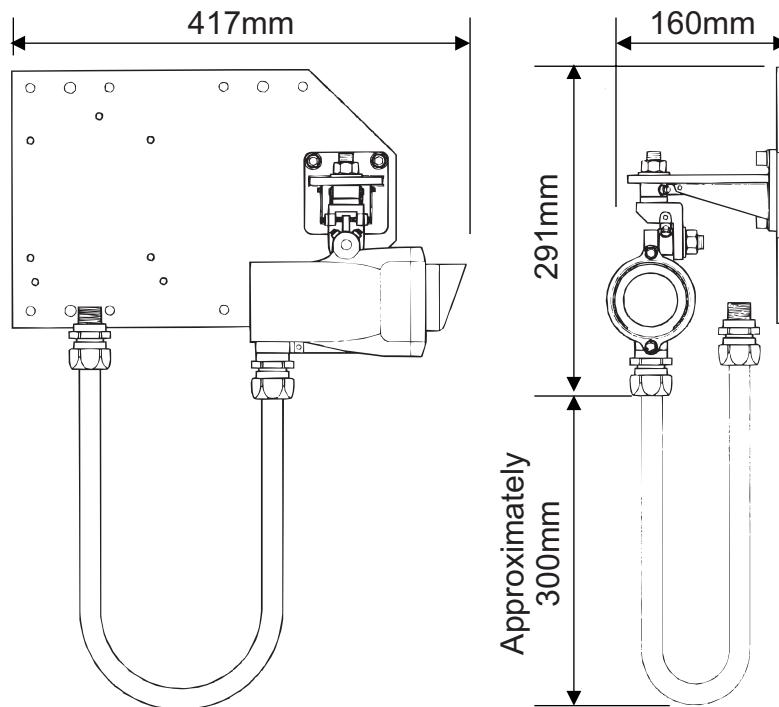

The solid state, photovoltaic detectors used in Searchline Excel provide an exceptional dynamic range and superb temperature and long term stability. These features contribute strongly to the solar immunity and stability of Searchline Excel.

The Receiver contains all of the electronics necessary to amplify, condition and process the signals received by the infrared detectors. The advanced signal processing of Searchline Excel employs two microprocessors.

One microprocessor, the Digital Signal Processor (DSP), is used to perform the necessary intensive signal processing calculations.

The other microprocessor, the microcontroller, controls the overall function of the unit and performs the final calculations to determine the correct gas reading and output state.

The primary output of the Receiver is a signal in the range 4 - 20mA and is available as either source or sink options. For most applications, the output is calibrated for a range of 0 to 5 LEL.m. (See **Appendix B** for the explanation of LEL.m and other terms)

The Receiver also features an RS485 output which is used to communicate with the associated SHC1 Handheld Interrogator. The SHC1 is used to perform final alignment, commissioning, functional testing and diagnostic procedures.

The Receiver window is heated to minimise condensation, frosting and the buildup of snow. The level of heating applied is controlled by the microcontroller and is adjusted from zero to maximum depending on the window temperature.

Electrical connections to the Receiver are made via wires which run through the protective flexible conduit. There are six Receiver wires, red (+24V), black (0V), white (4 - 20mA), orange (RS485 A), blue (RS485 B) and green / yellow (GND).

2. OVERVIEW

2.4 ADJUSTABLE MOUNTINGS

The adjustable mountings are:

- **Purpose-built for Transmitter and Receiver.**
- **Robust.**
- **Rigid and stable.**
- **Made from stainless steel.**
- **Fully adjustable for alignment**

Coarse and fine settings in both horizontal and vertical planes.

Adjustment range:

Vertical $\pm 45^\circ$

Horizontal $\pm 90^\circ$

Alignment details are given in **Chapter 3**.

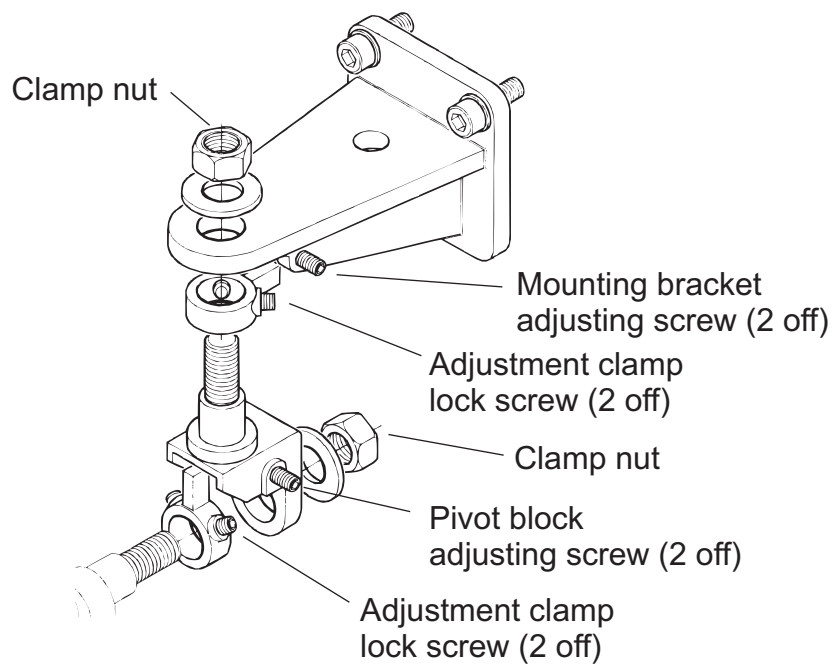

3. INSTALLATION AND OPERATION

3.1 INTRODUCTION



WARNING

The national Code of Practice regarding selection, installation and maintenance of electrical apparatus for use in potentially explosive atmospheres must be complied with at all times.

Most of the information and recommendations given here only apply to the Open-Path version of Searchline Excel. See **Chapter 4** for details about installing the Cross-Duct version of Searchline Excel.

Searchline Excel has been designed, engineered and customer tested to be the most robust, reliable Open-Path Gas Detector (OPGD) available to date.

The design and technology employed in Searchline Excel makes it far more resistant to the adverse effects of the operating environment and non-ideal installation engineering than previous generations of OPGDs.

With careful consideration of the intended operating environment and the installation design, the installer/operator can maximise the reliability, availability and performance achieved with Searchline Excel.

Before designing or specifying an installation for Searchline Excel, it is strongly recommended that the installation design authority reads all of this chapter and considers how the information and recommendations provided can be applied to their installation(s).

If you have any queries concerning your installation design, contact Zellweger Analytics or your local agents.

Zellweger Analytics is committed to ensuring that customers achieve reliable operation of their Searchline Excel Gas Detectors. For this reason, Searchline Excel should only be installed by fully trained personnel (trained by Zellweger Analytics or a Zellweger Analytics authorised trainer).

This training will provide the installer with a clear understanding of the Searchline Excel product and the associated accessories and tools. It will also provide familiarity with the installation, alignment and commissioning procedures, plus installation assessment skills to identify potential problem areas.

For each installation, an installation check sheet should be completed and returned to ZA or their agents. Details of this check sheet are given at the end of this chapter.

NOTE: THE INFRARED BEAM IS INVISIBLE AND EYE SAFE.

3. INSTALLATION AND OPERATION

3.2 SITING AND MOUNTING

3.2.1 General

When designing an installation for a Searchline Excel gas detector it is important to give consideration to where it is to be located, what potential sources of problems may be encountered in this location and how the unit is to be mounted and supported.

3.2.2 Location for Best Coverage

Guidance on the positioning of gas detectors to provide the best detection coverage is contained in BS6959 and other national Codes of Practice. It is recommended that the installation designer consults these Codes of Practice when determining where detectors are to be located. In general, the following positions usually provide the best results:

- **Below potential leak sources for gases that are heavier than air.**
- **Above potential leak sources for gases that are lighter than air.**
- **Near to leak sources, along the expected leak trajectory, taking account of the prevailing wind direction and any other factors which will influence propagation of the leak.**
- **Between possible leak sources and any potential sources of ignition.**

Location to Maximise Reliability and Availability

Care in choosing the location of Excel detectors can contribute significantly to the overall reliability and availability.

When locating units, attempt to avoid areas where they may be adversely affected by the following:

Vibration - Angular vibration of the structure to which Excel units are attached should be kept to less than +/- 0.5°. Where possible, avoid locations where high levels of vibration will be directly induced into the mounting structure. If close proximity to significant sources of vibration is unavoidable, take steps to reduce coupling of this vibration and maximise the rigidity of the mounting structure.

Intense Heat - Excel is certified and specified for operation in environments up to +65°C. If sources of intense heat (flarestacks, intense sunlight, etc.) are present, a sunshade (Part No: 2104B2323) or similar shield should be fitted to the unit to protect it from excessive heating.

Sources of Heavy Contamination - Avoid locations where high levels of contaminants will persistently be blown onto the unit's windows. Potential sources of heavy contamination include generator/turbine exhausts, flarestacks, drilling equipment, process vents/chimneys etc. If sources of heavy contamination cannot be avoided, consider fitting extra shielding and/or providing good access for more routine cleaning.

Snow and Ice in Ambients Below -20°C - The heated optics on Excel units will melt snow or ice on the windows in ambient temperatures down to approximately -20°C.

3. INSTALLATION AND OPERATION

Below this temperature, snow or ice blown onto the window will not be melted until the ambient temperature rises. If long-term, outdoor operation in very cold climates is intended, it is recommended that extra shielding/covers are employed to prevent snow/ice from being blown onto the windows and building up.

Note: The heated optics have not been evaluated as part of the performance testing relating to the FM approval and therefore are not considered part of the performance approval.

Deluge and Flooding - Searchline Excel is rated IP66/67 and as such will not be damaged by occasional deluge or flooding. However, during such instances the unit will completely lose its IR signal and will enter the BEAM-BLOCK/FAULT state. Also, when the deluge/flooding subsides, there is the possibility that contaminants will be left on the windows. Therefore, it is recommended that Excel units be located away from areas particularly prone to deluge or flooding.

Areas Prone to Subsidence and Settling - Where possible, it is recommended that Excel units are not mounted on structures located where problems with subsidence, settling or thawing of permafrost are known to cause significant movement. If such locations cannot be avoided, the foundations of the mounting structure should be engineered to minimise any angular movements.

Areas Prone to Earthquakes - In locations prone to earthquakes, there is a chance that during or after an earthquake, the units of an Excel gas detector will become misaligned with respect to each other. Provided that the Excel units do not suffer from direct mechanical impact damage during an earthquake, they should remain undamaged by such events. Anti-vibration mounts are unlikely to be of any benefit and are not recommended. After an earthquake it is recommended that Excel gas detectors are visited and their alignment be checked.

Accidental Impact - Locations where there is a significant likelihood of equipment, personnel or moving objects accidentally knocking Excel units out of alignment should where possible be avoided. If such locations cannot be avoided, measures including improved mechanical protection and warning notices should be considered.

Intense Electromagnetic Fields - Searchline Excel complies with EN50082 (Industrial levels) and as such is well protected from interference by electromagnetic fields. However, locations in close proximity to radio/radar transmitters, heavy electrical plant and high voltage power cables may experience field strengths in excess of those specified in EN50082. Where possible, such locations should be avoided or units should be installed as far as possible from the source of the electromagnetic field. Measures including additional screening, filtering and transient suppression may also be of benefit in such locations.

3.2.3 Beam Path

The Transmitter and Receiver units windows should face each other across the area to be protected and, depending on the range of the Transmitter in use, should be the following distance apart:

Excel Gas Detector type	Path length between units	
Short Range	5 - 40m	(15 - 130ft)
Medium Range	40 - 120m	(130 - 390ft)
Long Range	120 - 200m	(390 - 650ft)

3. INSTALLATION AND OPERATION

The beam path and immediate surrounds should be kept free of obstructions that might hinder the free movement of air in the protected area or block the infrared beam. A clear beam path of 20cm diameter or greater is recommended. In particular, for optimum availability, avoid areas affected by the following.

- a. Steam vents and plumes
- b. Smoke stacks and chimneys
- c. Walkways and personnel areas
- d. Splash and spray, e.g. from moving equipment, cooling towers, etc.
- e. Parking, loading, cranes, vehicle temporary stops, e.g. bus stops, road junctions, etc.
- f. Vegetation, e.g. shrubs, bushes, branches, etc. - if currently clear, movement due to weather and future growth or planting must be considered

Note: Where c. and d. cannot be avoided, consider indicating the beam by marking the walkway or road with paint.

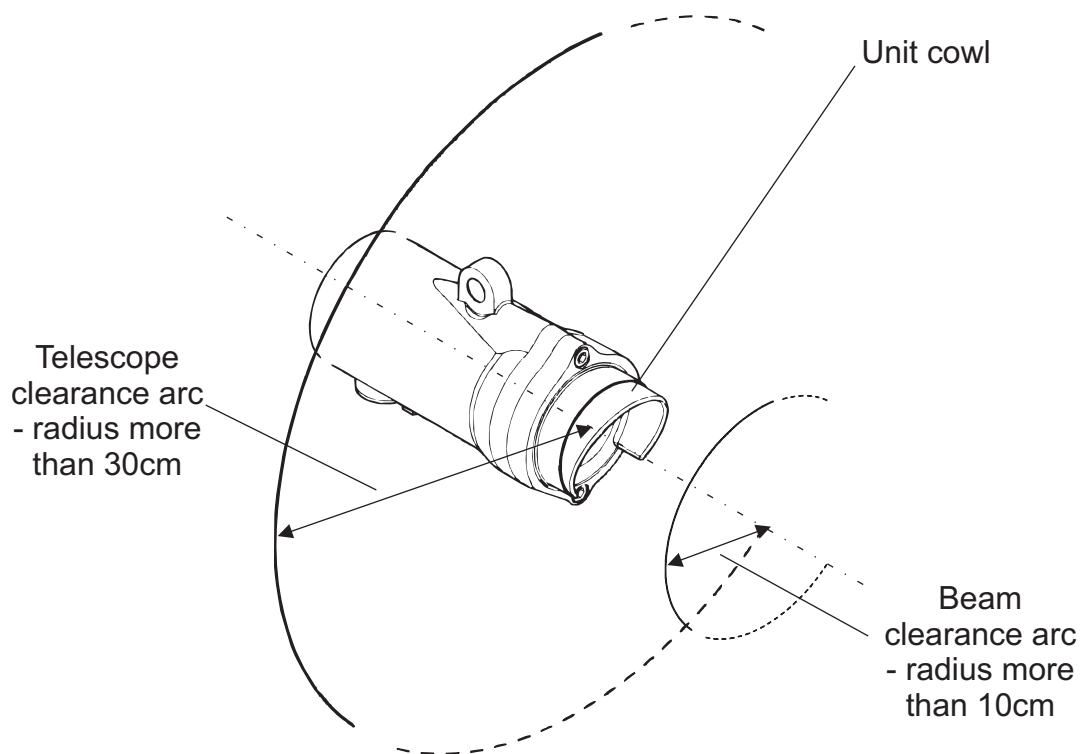

Notes:

1. *In order to fit the alignment telescope, used during the alignment process, a clear accessible arc of at least 30cm radius is required close to the unit's cowling as shown.*
2. *A clear beam path of at least 10cm radius or greater is recommended.*

3. INSTALLATION AND OPERATION

3.2.4 Supporting Structure

The Transmitter and Receiver units should be fixed to a **stable** supporting structure using the mounting plates supplied.

Note: The maximum movement of the supporting structure under all anticipated operating conditions must be $\pm 0.5^\circ$.

If either unit is to be free standing and not mounted to existing supports or structures, and the height above the ground is no more than 3m, the supporting structure shown is recommended:

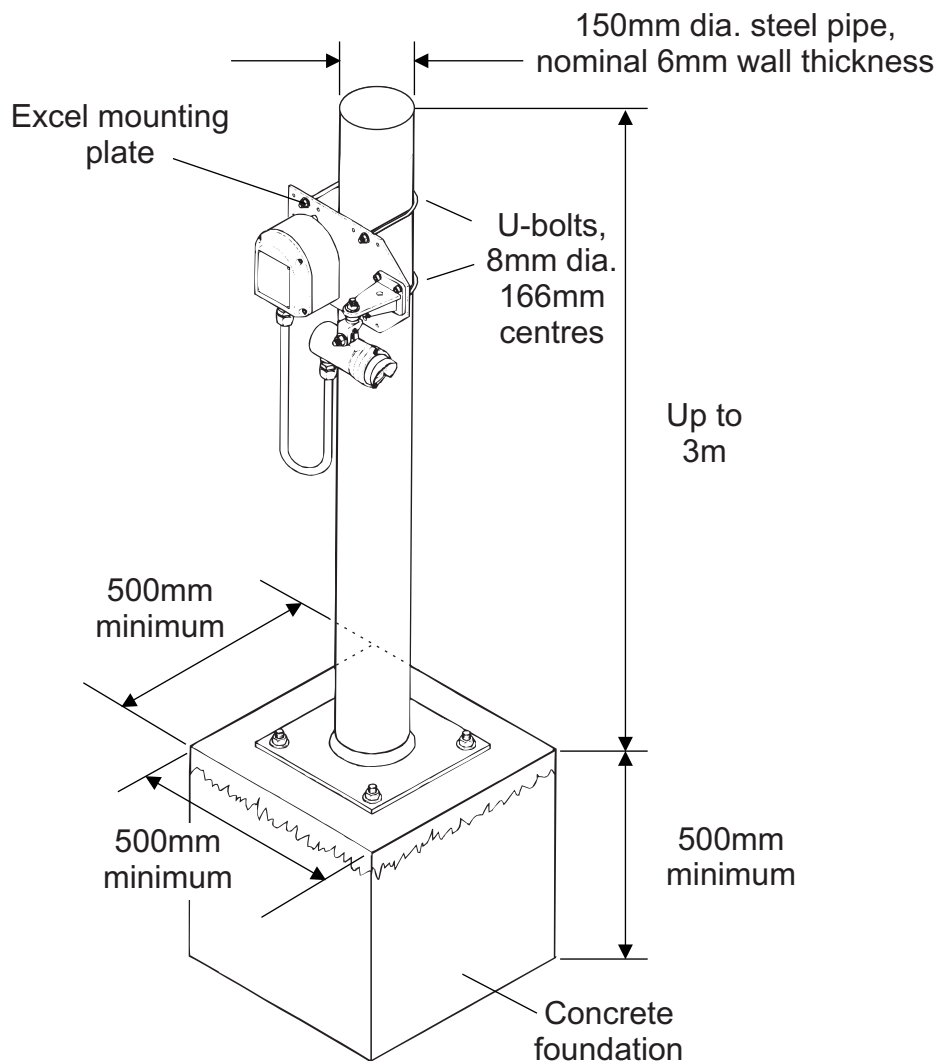

Note: The pipe can be filled with concrete to provide extra robustness if necessary.

3.2.5 Orientation

Searchline Excel is solar immune and therefore there is no need to take account of the sun's movement when considering orientation.

When positioning the units do not install them with the optical axis at an angle greater than 45° to the horizontal. This is to avoid dirt/water buildup on the windows.

3. INSTALLATION AND OPERATION

3.3 ELECTRICAL CONNECTIONS

3.3.1 General

All ranges of Searchline Excel comply with the EMC requirements EN50081 and EN50082. In order to maintain compliance with these standards it is essential that the electrical installation of Excel is engineered correctly.

Electrical installation standards vary for different countries, companies and applications and it is the responsibility of the installation design authority to determine the applicable standards and ensure compliance with them. When designing electrical installations for Excel, Zellweger Analytics recommend that the installation design authority considers the following:

- a. The unit cases should not, if possible, be connected to electrically noisy (*dirty*) metalwork or conductors. Preferably, the case (internally connected to the green/yellow GND wire) should be connected to a low noise instrument (*clean*) earth. See also para e. below. In order to facilitate electrical isolation of the Searchline Excel from a noisy earth an isolation kit is supplied. This kit should be fitted as standard unless local regulations forbid this.
- b. The entire length of the field cabling connected to each unit should be fully shielded. This should be connected to a low noise (*clean*) earth.
- c. The low noise instrument (*clean*) earth system should only be connected to safety earth (usually *dirty*) at a single point on the entire site/installation. This connection should be made in such a manner that it does not introduce noise onto the low noise instrument earth. Star earthing arrangements minimise earth current crosstalk.
- d. The shields of the field cabling should not be connected such that earth loops are produced, or in a manner that will result in the shields carrying large currents from heavy plant or equipment.
- e. Ideally, the field cable shield should be connected to the unit's green/yellow GND wire, providing a single, continuous earth shield. This connection **must not** be allowed to complete an earth loop.
- f. The earth bonding arrangement must ensure that the maximum peak voltage between the unit case earth and any field cable conductor is less than 350V. Voltages in excess of this can cause permanent damage to the unit's RFI protection filters.
- g. The use of a single, screened cable for each gas detector ensures maximum screening and minimum crosstalk. Cabling arrangements which use a single cable for connecting a number of field devices compromise screening, increase the potential for crosstalk and prevent implementation of true star earthing.
- h. Any electrical interference induced onto the 4 - 20mA loop conductors by the installation must be kept below the levels necessary to comply with the general requirements of EN50054. In practice, this means that peak noise currents induced on the current loop should be no greater than $\pm 0.25\text{mA}$.
- j. The 0V rail of the control card/control system is directly connected to one side of the 4 - 20mA current sensing resistor. Electrical noise on this rail is therefore directly connected to the 4 - 20mA input. In order to avoid additional noise being induced on the 0V rail, it should not be commoned with the safety earth/ground, which frequently carries a high level of electrical noise.
- k. All electrical equipment connected to the gas detector should comply with EN50081 and EN50082.

3. INSTALLATION AND OPERATION

- l. The 24V supply should be free from large transients and fluctuations.
- m. The field cabling conductors should have sufficient cross sectional area to ensure that the minimum supply voltage applied to the gas detector is 18V at a current of 420mA. This corresponds to a maximum round loop impedance of 14 ohms for a nominal 24V system supply.
- n. Receivers should not be installed in close proximity to the antennae of high powered radio, radar and satellite communication equipment.

3.3.2 Receiver Connections via DVC100

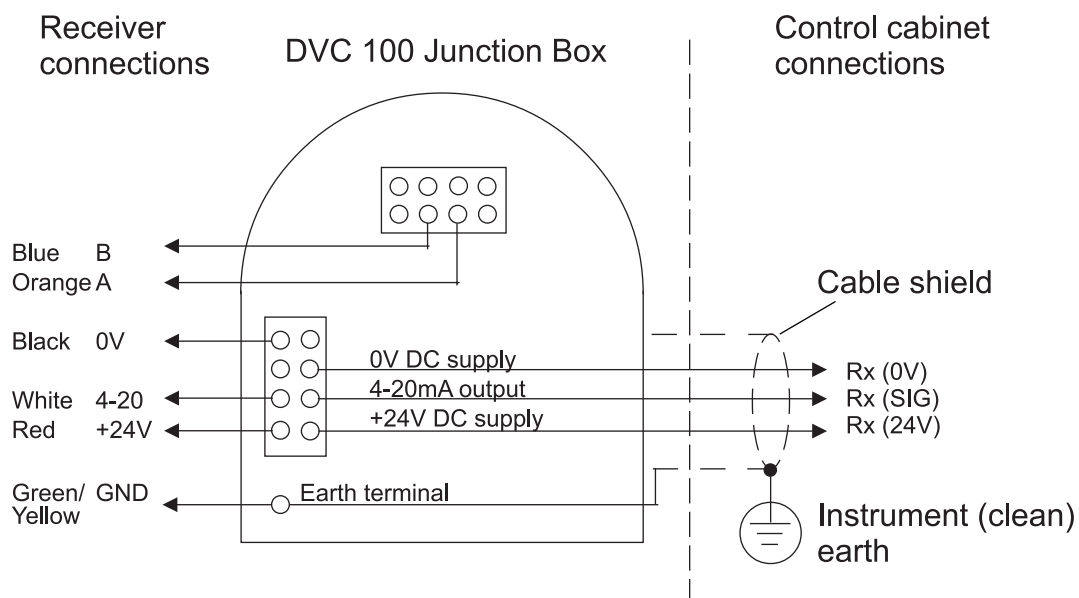

3.3.3 Receiver Connections via DX100

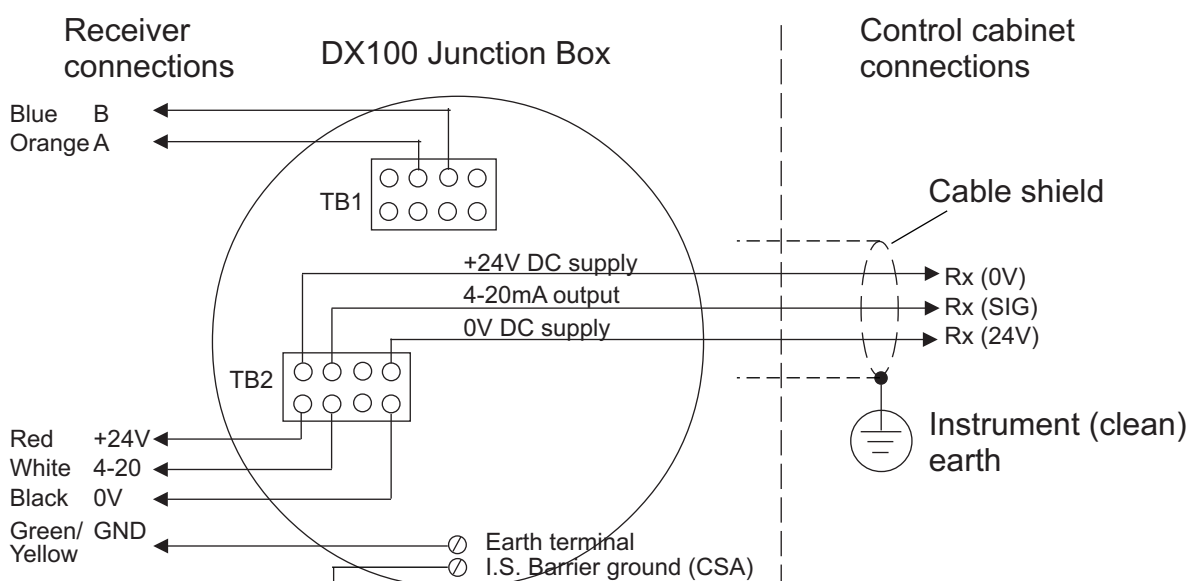

Safety/protective ground

The earth bonding arrangement must ensure that the maximum peak voltage between the unit case earth and any field cable conductor is less than 350V. Voltages in excess of this can cause permanent damage to the unit's RFI protection filters.

3. INSTALLATION AND OPERATION

3.3.3 Receiver Connections via DX100 (M)

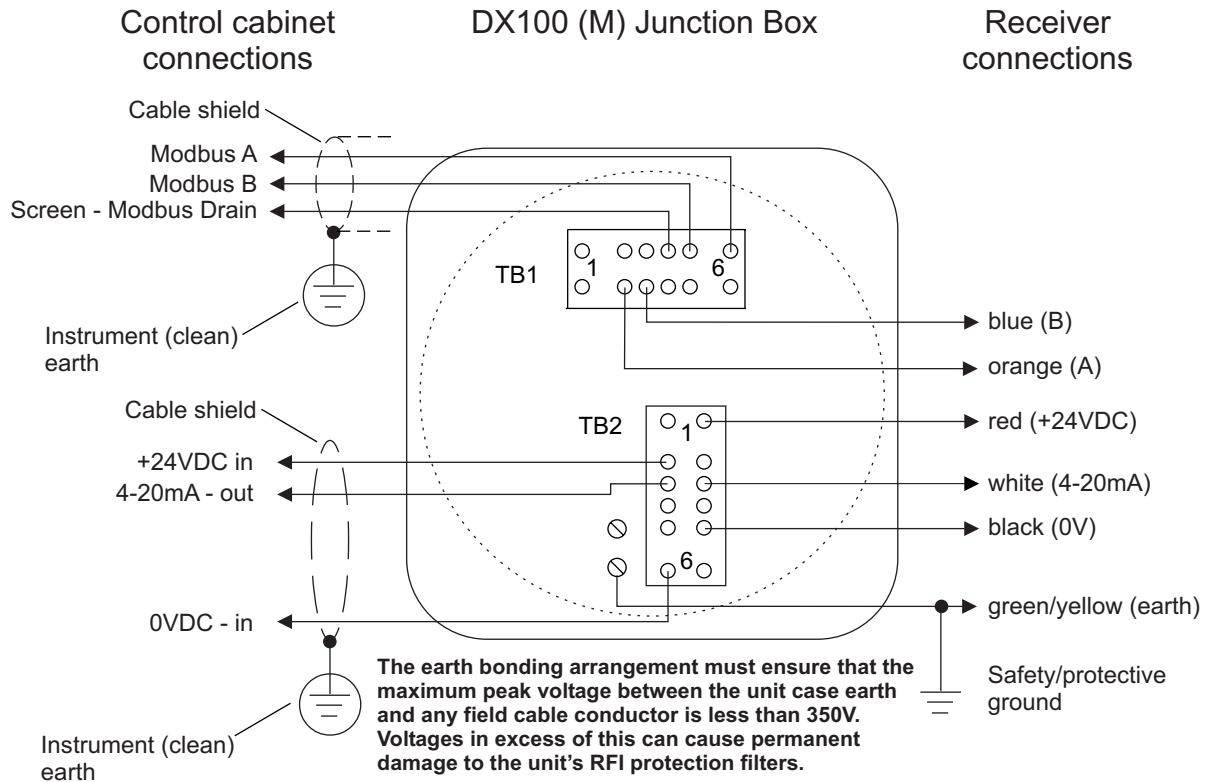

3.3.4 Transmitter Connections

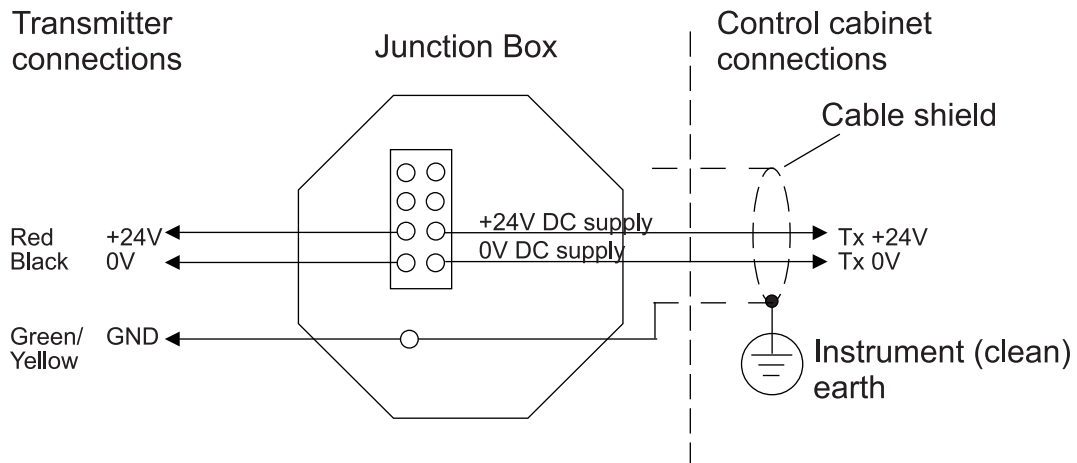

3. INSTALLATION AND OPERATION

3.3.5 Remote Installations

For remote or difficult-to-access installations, the DVC100/DX100/DX100 (M) can be positioned in a convenient location by using an intervening junction box (e.g. PL612/AKRON/Killark) attached to the Receiver's mounting plate.

A maximum cable length of 1km between the unit and the DVC100/DX100/DX100 (M) is permissible (RS485 compliant).

The connections are as follows.

Wiring with DVC100/DX100

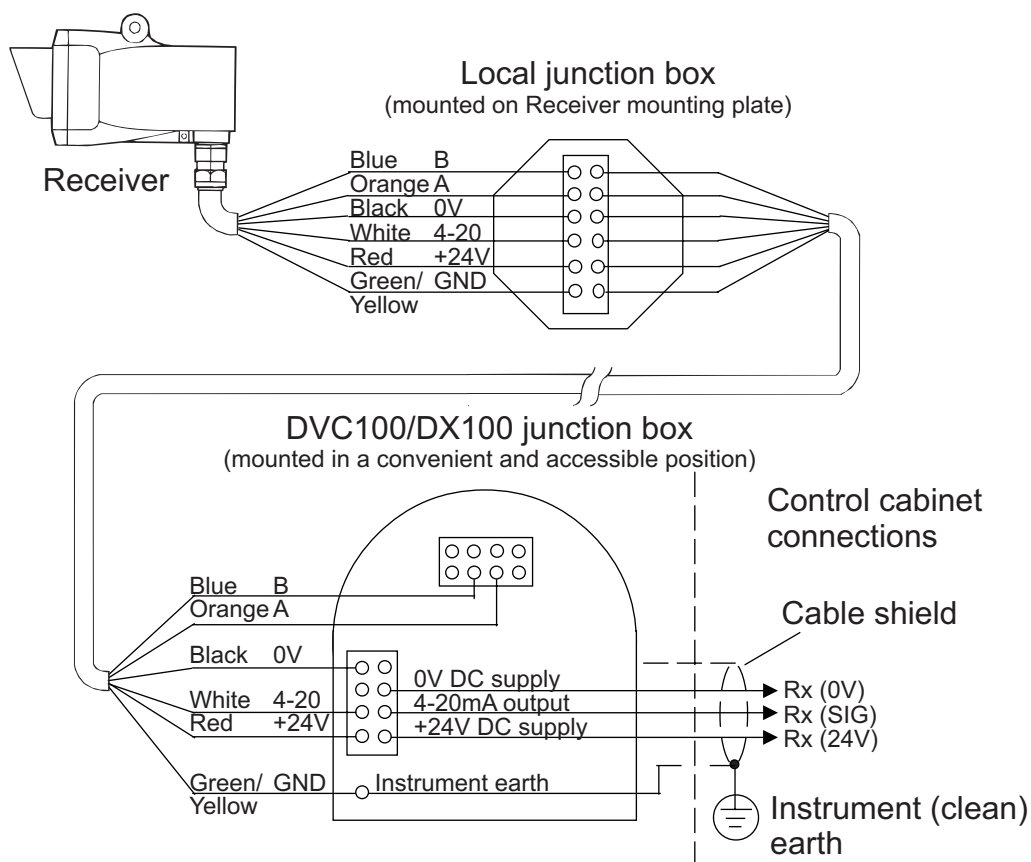

3. INSTALLATION AND OPERATION

Wiring with DX100 (M)

See also DX100 Termination Units Technical Handbook.

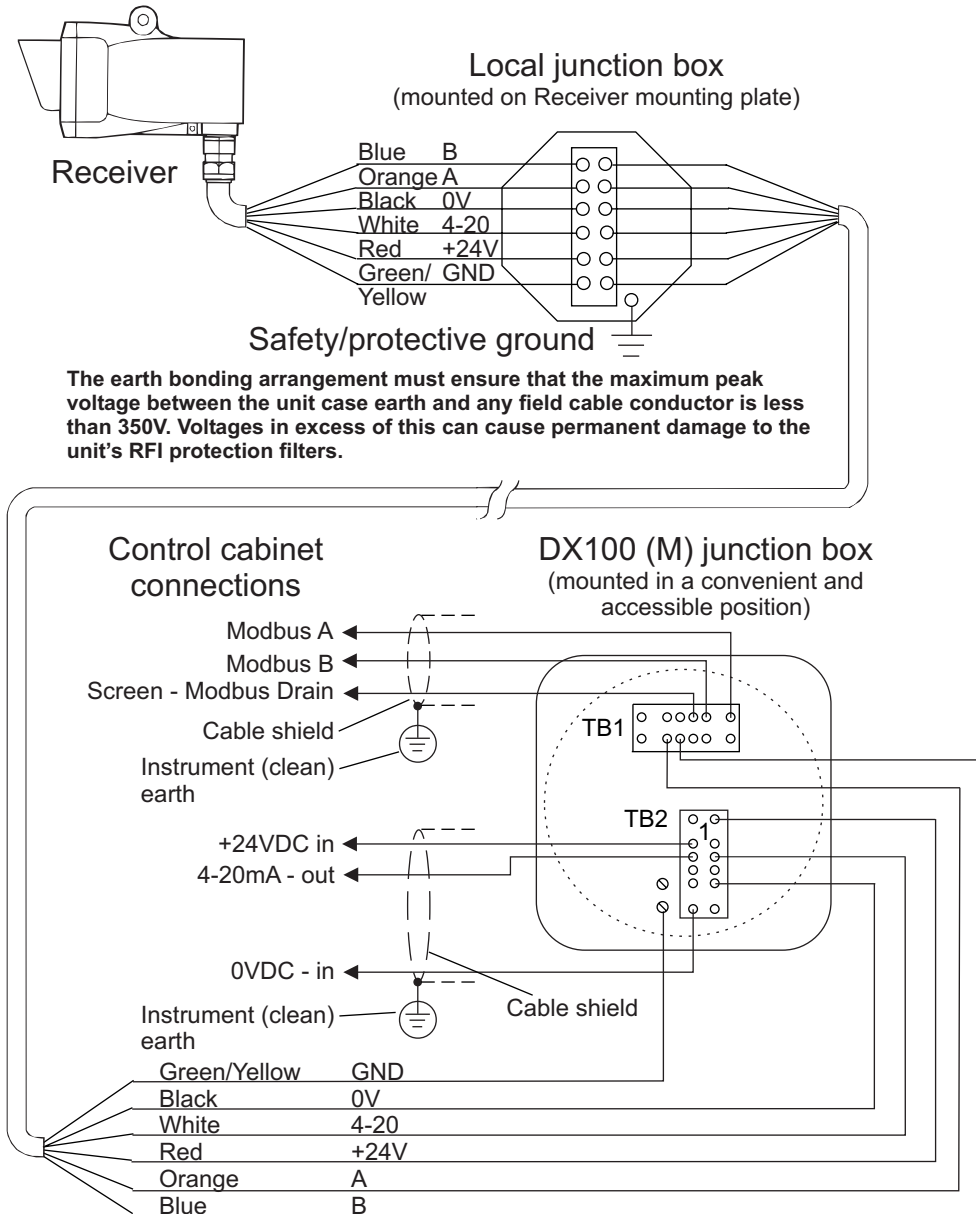

3. INSTALLATION AND OPERATION

3.4 POWER SUPPLY

3.4.1 General

The Searchline Excel gas detector is designed to be operated from a nominal 24V DC supply. The supply voltage at the terminals must be within the range 18 to 32V.

The unit maximum power consumption and cable lengths are as follows:

Unit Type	Maximum Power Consumption (W)	Maximum Cable Length (m) with 1.5mm ² Conductors (12 ohms/km)	Maximum Cable Length (m) with 2.5mm ² Conductors (7.6 ohms/km)
Receiver (All ranges)	8	550	900
SR Transmitter, (Turbo heating enabled)	5	900	1,400
SR Transmitter, (Turbo heating disabled)	3.5	1,300	2,000
MR/LR Transmitter, (Turbo heating enabled)	7.5	600	950
MR/LR Transmitter, (Turbo heating disabled)	5.5	820	1,300

Notes:

1. Control room supply voltage assumed to be +24V.
2. Standard configuration of the Transmitter is with turbo heating enabled.

Terminal sizes: DVC-100	0.5mm ² - 4mm ² (20AWG - 12AWG)
DX-100/DX100 (M)	0.5mm ² - 4mm ² (20AWG - 12AWG)
PL612	0.5mm ² - 6mm ² (20AWG - 10AWG)

3.4.2 Power Supply Connections - Turbo heating Disabled

When connected as shown in section **3.3.4 Transmitter Connections** all ranges of Transmitter have turbo heating mode enabled.

This means that during conditions of low ambient temperature, additional heating power is applied to the unit's window to minimise condensation, frosting and snow buildup.

If the application/installation does not require turbo heating, reduced power consumption can be achieved by disabling this mode.

The turbo heating is disabled by reversing the power supply connections to the Transmitter as shown in the following diagram. All other connections remain the same.

3. INSTALLATION AND OPERATION

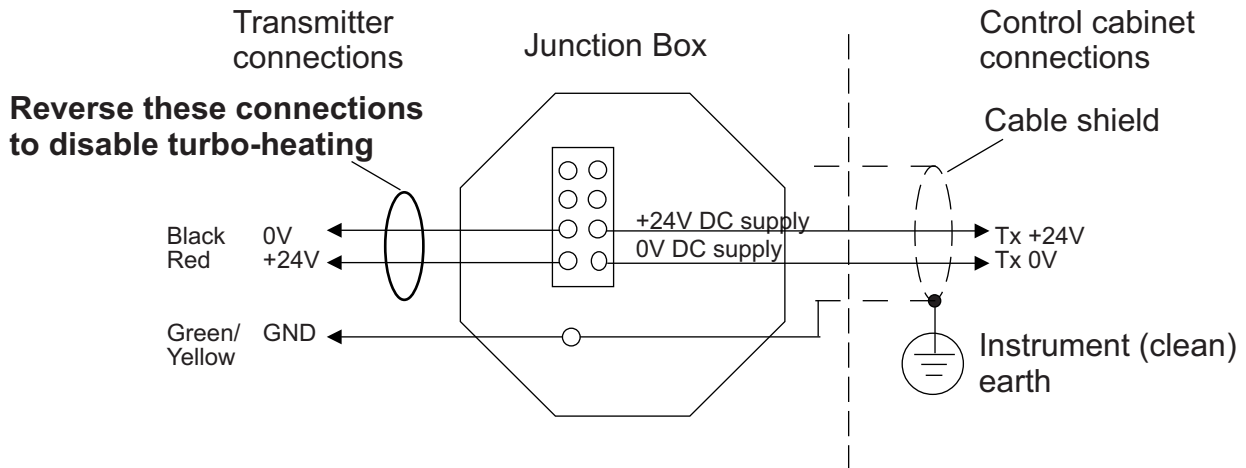

Notes:

1. Only Transmitters have turbo mode heating which can be disabled. The Receiver uses proportional heating, which cannot be disabled.
2. Even with turbo mode heating disabled the Transmitter window still receives standard levels of heating.
3. Do not reverse the Receiver power supply connections. This will not damage the unit, but the unit will not work.

3.5 UNPACKING

- (1) Carefully unpack the equipment, observing any instructions that may be printed on or contained within the packaging.
- (2) Check the contents for damage and against the packing note for deficiencies.

In the event of damage or loss in transit, notify the carrier and Zellweger Analytics or your local agent immediately.

The gas detector consists of the subsequent items.

Where alternative component sizes are given the size depends on the version of unit, i.e. mid/long range version or short range version.



1 x Receiver Unit

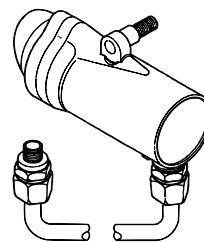

1 x Transmitter Unit

3. INSTALLATION AND OPERATION

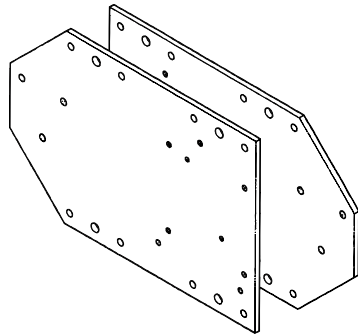

2 x Mounting Plate

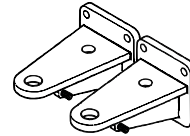

**2 x Mounting Brackets
(with grub screws)**

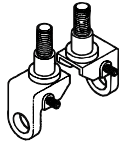

**2 x Pivot Blocks
(with grub screws)**



**4 x Adjustment Clamps
(with grub screws)**



4 x Nyloc Self-locking Nuts



4 x Washers (M12 or M20)



**6 x Mounting Bracket
Fixing Bolts
(M10 or M12)**



8 x Junction box Mounting Bolts

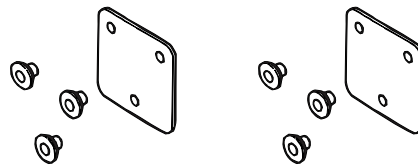

2 x Isolation Kit

3. INSTALLATION AND OPERATION

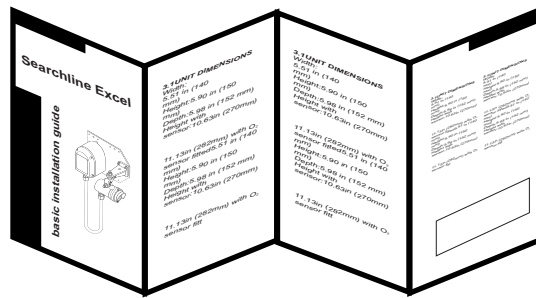

Basic Installation Guide

2 x Allen (Hex) Keys (3mm or 5mm)

- (3) Ensure that the installer/end user of the equipment receives the technical documentation (operating instructions, manuals, etc.) contained in the packaging.

3. INSTALLATION AND OPERATION

3.6 INSTALLATION PROCEDURE

3.6.1 General

Searchline Excel is designed to allow installation and alignment to be performed by a single technician.

The installation procedure is split into mechanical installation and electrical installation. Each unit needs to be mounted to a supporting structure before making the electrical connections.

3.6.2 Mechanical Installation

The mechanical installation procedure applies to both the Receiver and the Transmitter.

- (1) Ensure that the gas detector equipment supplied is compatible with the required application (i.e. short, medium or long range).
- (2) Fit the mounting bracket and isolation kit to the mounting plate for the unit as shown:

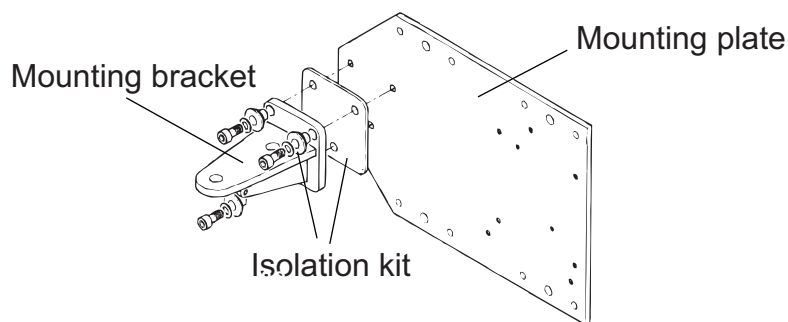

- (3) Fit the mounting plate to the supporting structure.
The plate can be fitted in one of the following ways:
 - a. *With bolts directly to a flat surface.*
 - b. *With U-bolts (2 off) to a single 150mm diameter pipe or pole.*
 - c. *With U-bolts (4 off) to two 55mm diameter pipes or poles, 166mm apart.*Identify the required mounting holes from the following drawing and table:

3. INSTALLATION AND OPERATION

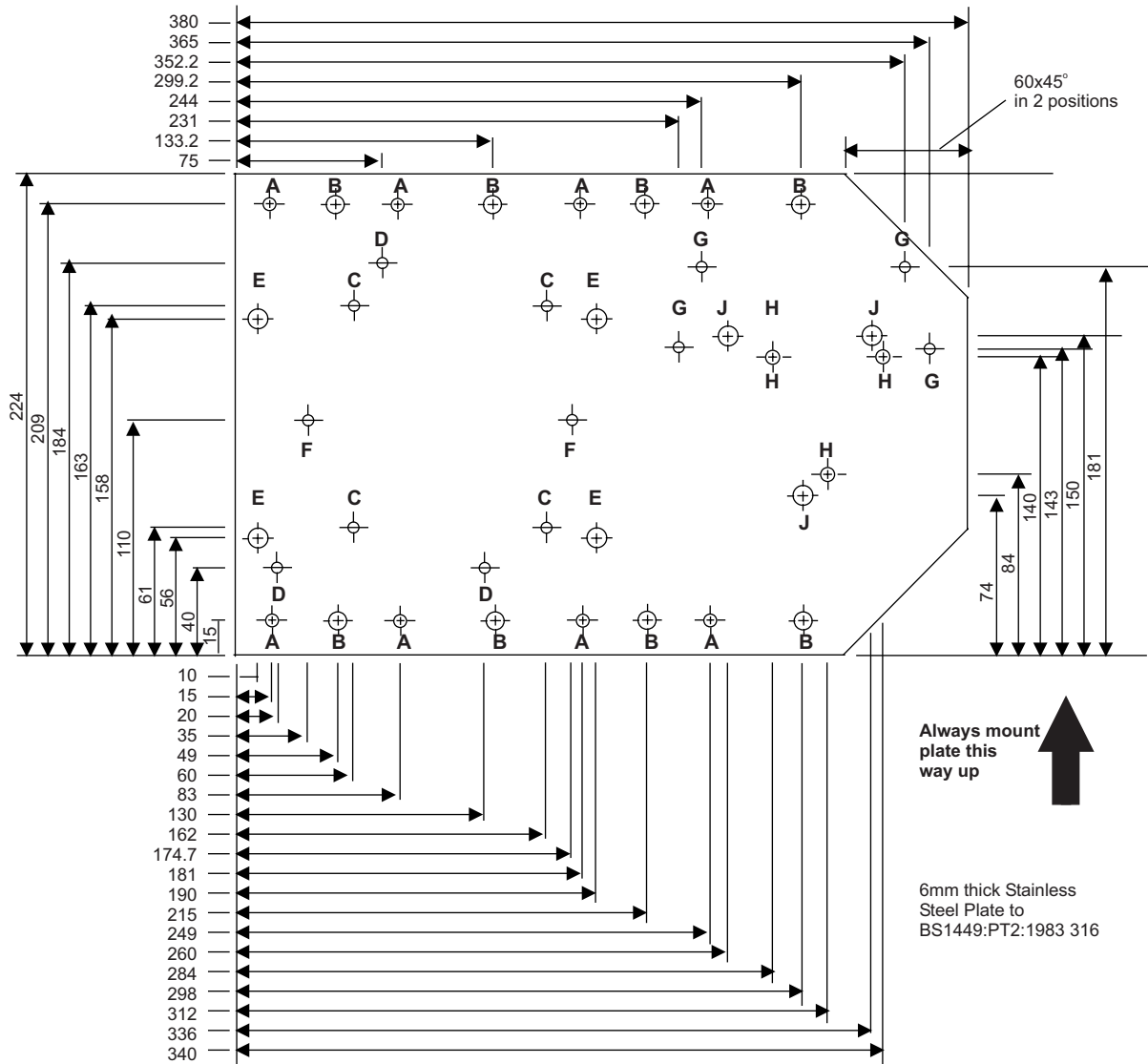

Notes:

1. Drawing is **not** to scale.
2. Mounting plate fixing holes are clear. Searchline Excel gas detector component mounting holes are tapped.
3. The mounting plate fixings are not supplied.

Identity	Quantity	Size	Used For
A	8	Ø 7.5mm	Dual 2" pipe or pole mounting, flat surface mounting.
B	8	Ø 9.5mm	Single 6" pole, flat surface mounting, Dual 2.5" ID pipe.

3. INSTALLATION AND OPERATION

C mounting	4	M6 tapped	PL612/Bartec junction box
D	3	M6 tapped	DVC100 junction box mounting.
E	4	M10 tapped	DX100/DX100 (M) junction box mounting.
F mounting.	2	M6 tapped	Killark/Akron junction box
G	4	M6 tapped	Sun/heat shade mounting.
H	3	M8 tapped	Short range Transmitter and all Receiver brackets.
J	3	M10 tapped	Medium/Long range Transmitter mounting bracket.

The following drawings show typical mountings:

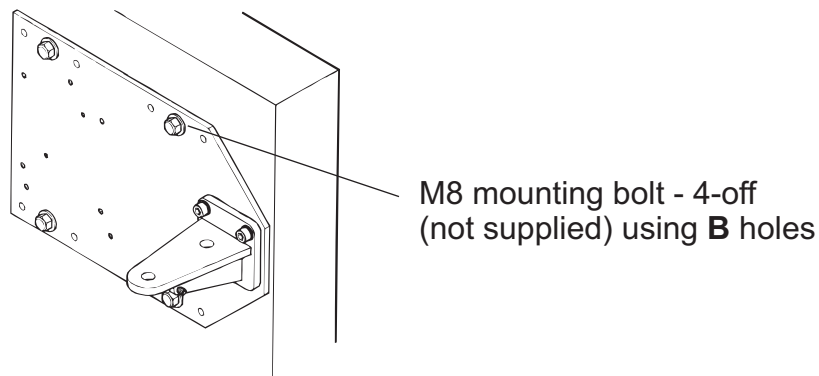

Mounting Plate Fixed to Flat Surface

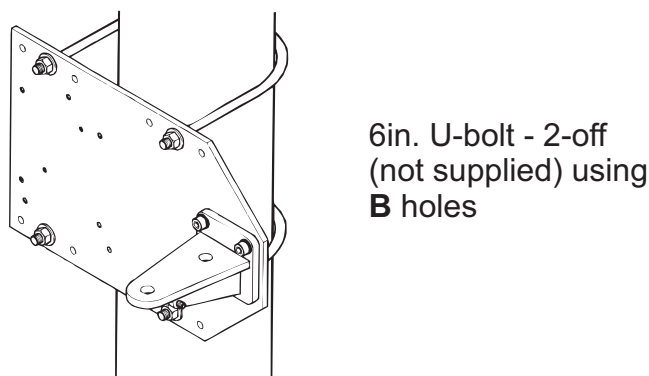

Mounting Plate Fixed to Single Pipe/Pole

3. INSTALLATION AND OPERATION

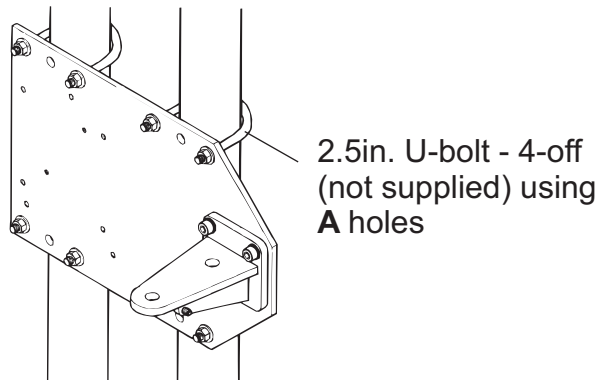

Mounting Plate Fixed to Twin Pipes/Poles

- (4) Fit an adjustment clamp to the unit's pivot block mounting stud so that it sits on the stud's shoulder. The correct orientation for the pivot blocks and clamps is as follows:

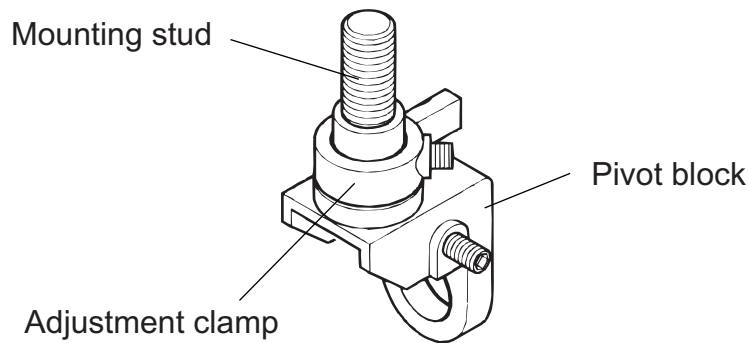

- (5) Tighten the adjustment clamp's grub screws until they just grip the unthreaded part of the stud.
- (6) Fit the pivot block to the mounting bracket using a self-locking clamp nut and washer (M12 or M20). The correct orientation for the pivot blocks and mounting brackets is as follows:

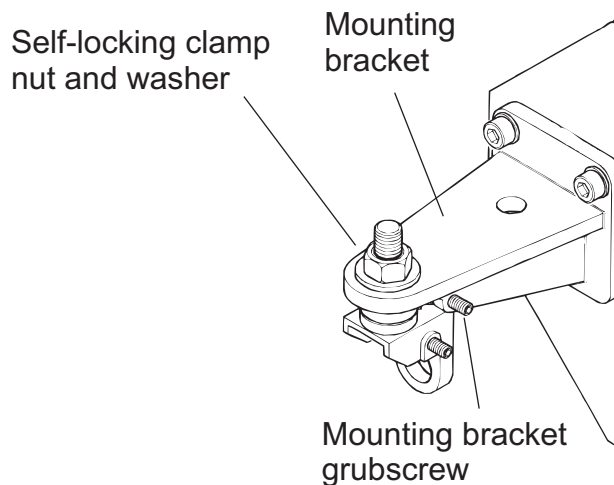

Do not fully tighten the nut.

3. INSTALLATION AND OPERATION

Ensure that the adjustment clamp's stub lever is approximately centrally positioned between the mounting bracket's grub screws. Adjust the screws if required.

- (7) Fit an adjustment clamp to the unit's mounting stud so that it sits on the stud's shoulder. The correct orientation for the adjustment clamp is as follows:

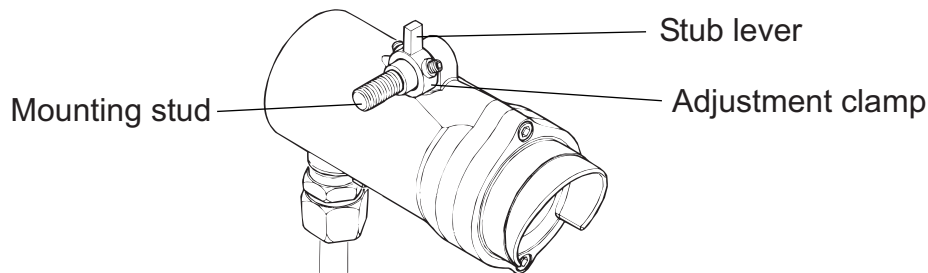

- (8) Tighten the adjustment clamp's grub screws until they just grip the unthreaded part of the unit's mounting stud.
- (9) Fit the unit to the pivot block using a self-locking clamp nut and washer (M12 or M20).

Do not fully tighten the nut.

At this point position the units on their mountings so that their optical windows face each other as shown:

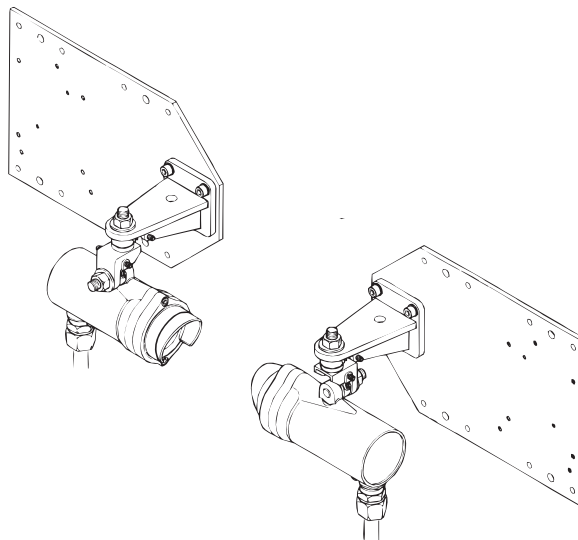

Ensure that the adjustment clamp's stub lever is approximately centrally positioned between the pivot block's grub screws. Adjust the screws if required.

- (10) Fit a suitable junction box, e.g. DVC100 or DX100 or DX100 (M) or other suitable type of junction box, to the mounting plate. A typical installation with junction boxes is as follows:

3. INSTALLATION AND OPERATION

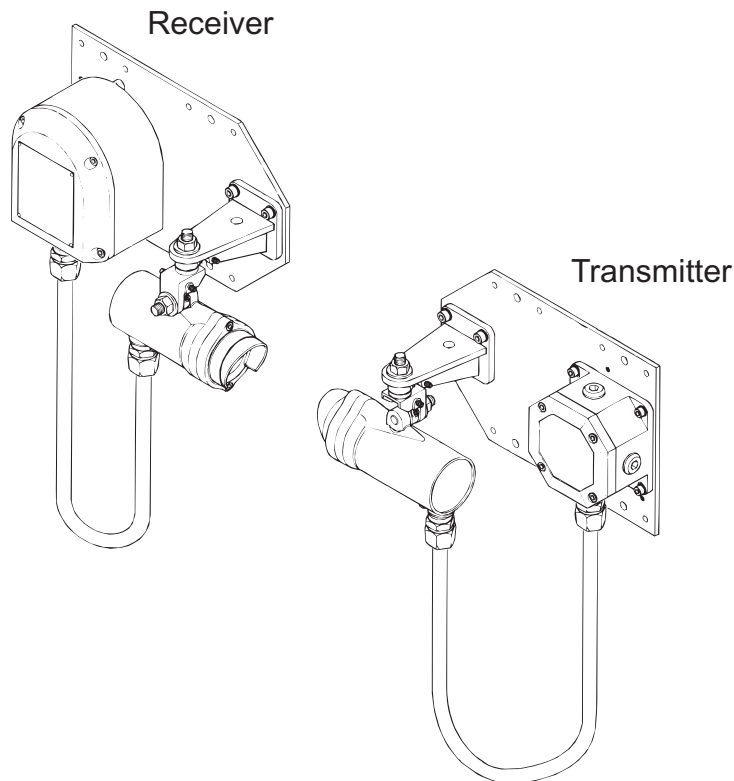

Note: For information about alternative types of junction box see section 3.6.2 Electrical Installation.

- (11) Measure and record the distance (in metres) between the Transmitter and Receiver units.

This distance is required later in the alignment procedures.

3.6.2 Electrical Installation

- (1) Isolate all associated power supplies and ensure that they remain **OFF** until the instruction in the commissioning procedure to apply power.
See section 3.7 Alignment and Commissioning. If the units are to be installed with junction boxes other than DVC100/DX100/DX100 (M) types, ensure that the boxes have:
 - a. *M20 cable gland entries for BASEEFA units, or 3/4 NPT for UL and CSA*
 - b. *terminals for five wires and an earth.*
- (2) Remove the M20 blanking plugs (if fitted) and attach the Searchline Excel Transmitter and Receiver cables to their junction box.
Fit the locking rings (if supplied) before terminating the cables in the junction box.
- (3) Fit approved cable glands to the junction box cable entries.
Use sealing washers where necessary to maintain the ingress protection rating.
- (4) Fit approved blanking plugs to all unused cable entries.
- (5) Make electrical connections.
See section 3.3.

3. INSTALLATION AND OPERATION

3.7 ALIGNMENT AND COMMISSIONING

WARNING

Do not attempt to view the Sun through the optical telescope.

3.7.1 General

In order to avoid unnecessary problems, alignment and commissioning of Searchline Excel gas detectors should only be performed by personnel trained by Zellweger Analytics.

To ensure optimum performance the gas detector Transmitter and Receiver units must be accurately aligned with a clear line of sight between them.

The Transmitter unit is first aligned with the Receiver using a telescope attached to the body of the unit. The telescope is then fitted to the Receiver and the alignment procedure repeated.

The Handheld Interrogator is then attached to the Receiver to finally commission the equipment and, depending on the type of Receiver, may need to be used to assist in fine-tuning the alignment.

The procedure can be performed by a single technician.

Each gas detector unit features a mounting assembly that allow both coarse and fine mechanical adjustment in the horizontal and vertical directions as shown in the subsequent diagram.

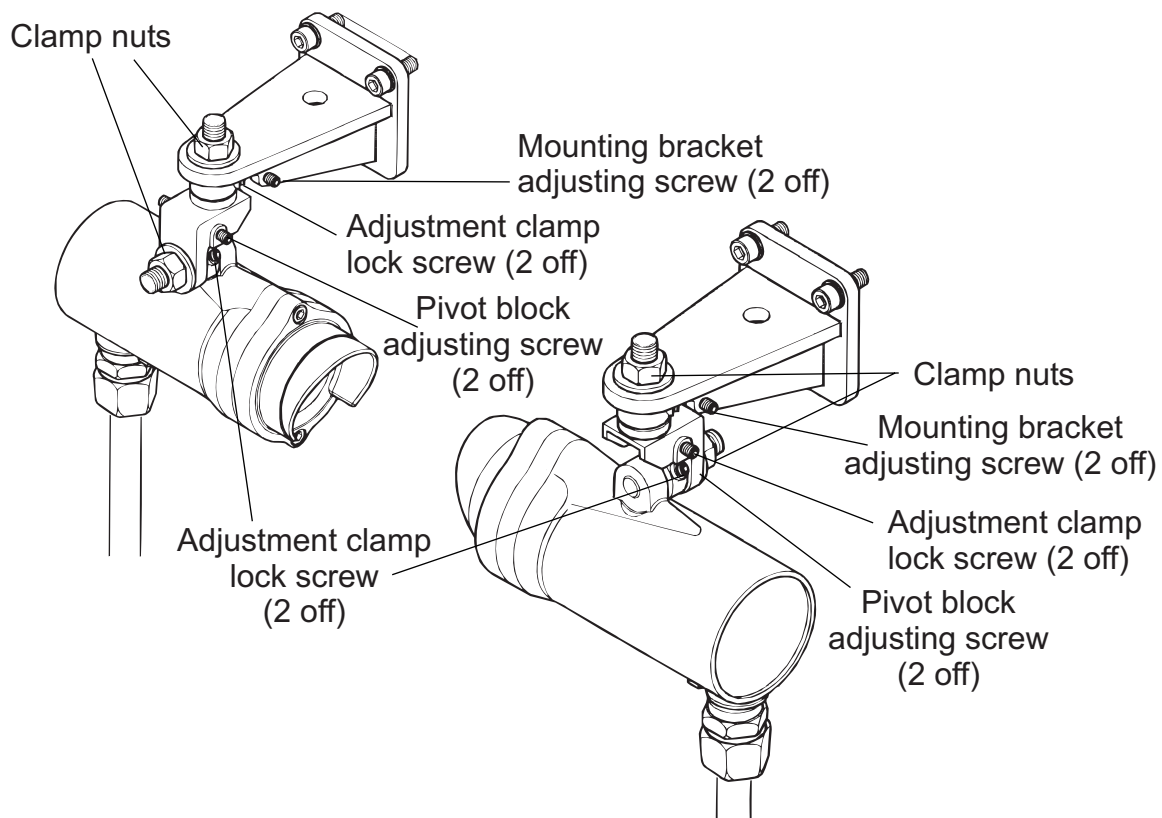

3. INSTALLATION AND OPERATION

Initial coarse mechanical adjustment is first carried out by means of large self-locking clamping nuts and with the help of an alignment telescope.

Fine adjustment is then achieved by means of mounting bracket and pivot block grub screws which move levers on the adjustment clamps, fitted to the pivot block and unit studs, and hence the unit.

After initial mechanical setup the units are powered up and the mechanical alignment is optimised and verified electronically by means of the associated Handheld Interrogator linked to the Receiver.

By entering the operating range of the gas detector the Interrogator then provides reassurance that the alignment has been performed successfully. The gas detector cannot be put into service until it is.

The following equipment is used to carry out the alignment and commissioning:

- Alignment Telescope suitable for the distance between the units (see **Appendix C - Accessories & Spare Parts**).
- SHC1 Handheld Interrogator (see Appendix C - Spare Parts).
- Optional SHC Protection Device (see **Appendix C - Accessories & Spare Parts**) - see Note 8.
- Appropriate plastic test filters (see **Chapter 5**, section 5.1.2).
- 3mm hex (Allen) key (with additional 5mm key for mid/long range gas detectors).
- 19mm spanner (with additional 30mm spanner for mid/long range gas detectors).

Notes:

1. *Ideally, carry out the alignment procedure on a clear day.*
2. *Get familiar with the workings of the adjustable parts of the gas detector before proceeding with the alignment procedure, see section 3.7.4.*
3. *The alignment telescope uses the same datum used when the unit was aligned in the factory to ensure precise field alignment.*
4. *The telescope incorporates eye relief adjustment for comfortable viewing.*
5. *Keep the telescope mirror and optics clean.*
6. *Do **not** try to adjust the cross-hairs using the telescope's elevation and windage adjusters as they have been factory set.*
7. *If the telescope is damaged or misaligned it will need to be returned to the factory for repair or realignment.*
8. *The SHC Protection Device is only required if connecting the SHC1 Handheld Interrogator via a junction box other than a DVC100 or DX100 or DX100 (M).*

3. INSTALLATION AND OPERATION

3.7.2 Alignment Procedure

The following summarises the alignment procedure:

- **Basic gas detector alignment, see section 3.7.3.**
- **Accurate alignment of Transmitter and Receiver using the appropriate alignment telescope, see section 3.7.4.**
- **Power-up and verify alignment using SHC1 Handheld Interrogator linked to the Receiver, see section 3.7.5.**

3.7.3 Basic Gas Detector Alignment

The basic procedure for aligning the Transmitter and Receiver units is the same.

- (1) Loosen the two clamping nuts and four adjustment clamp screws on the Transmitter and Receiver units until the units move freely in all axes.
- (2) Point the Transmitter and Receiver units so that they face each other across the area to be protected.
- (3) Tighten the clamping nuts and adjustment clamp grub screws on each unit until the unit cannot be moved by hand.

This is the last time that these clamp nuts and grub screws should need to be tightened. Further tightening later on will affect the fine adjustment and should be avoided.

Note: The unit can still be moved by the adjustment screws.

3.7.4 Accurate Alignment

The procedure for accurately aligning the Transmitter and Receiver units is the same.

Before making any adjustments consult the following table to ensure that the correct type of telescope is used with the Excel units that are to be aligned.

Excel Type	Type of <i>Trident</i> telescope that can be used	SHC1 Handheld Interrogator required to finalise alignment?
<i>Trident</i> Excel	Latch-type	No
	Bayonet-type	No
<i>Non-Trident</i> Excel	Latch-type	Yes

To tell the difference between the two types of Excel look at the front face of the units. The Trident-type Excel units have three small pads on their front face, the non-Trident types do not.

These pads provide three contact points (hence the term Trident) for the alignment telescope assembly datum mount to ensure accurate fixing of the telescope so that subsequent alignment of the gas detector units is precise.

The following diagrams illustrate the differences.

3. INSTALLATION AND OPERATION

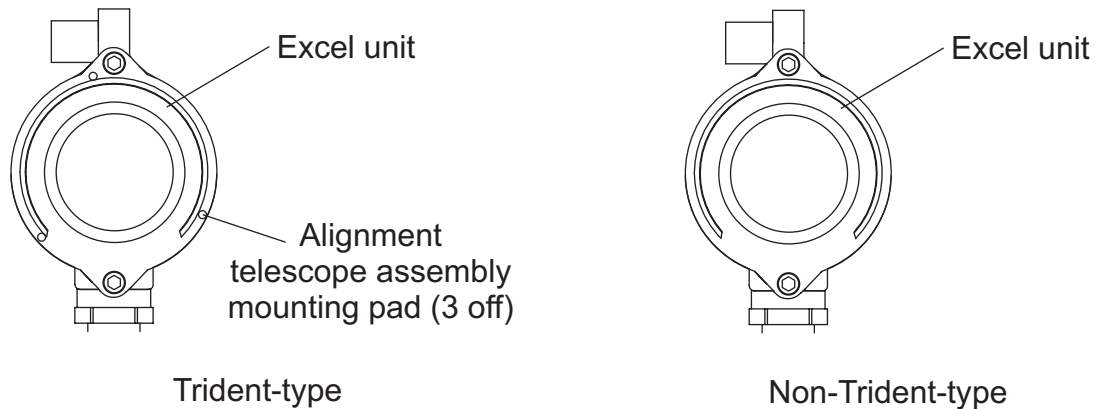

After deciding from the table which alignment telescope to use for the Excel units being aligned the telescope assembly must be fitted to each of the units in turn starting with the Transmitter. There are two ways of attaching the telescope to the Excel units - using latches or using a bayonet fitting. Depending on the type supplied refer to the relevant procedure described subsequently.

Each type of telescope assembly is available in two sizes. A small version is used to align the short range Excel units whilst the medium and long range Excel units are aligned using a larger medium/long range version of telescope.

Latch-style Trident-type telescope assembly

This telescope assembly consists of a telescope and mirror assembly attached to a datum mount that features a latching mechanism. It can be used with either the Trident or non-Trident types of Excel units.

When used with the non-Trident Excel the alignment may also need to be fine-tuned and then verified using the SHC1 Handheld Interrogator.

The latches are used to lock the whole assembly onto the body of the Excel unit.

Before securing the latches the telescope can be rotated to a convenient viewing position.

To remove the telescope assembly reverse the following fitting procedure.

- (a) Fit the datum mount of the alignment telescope securely over the cowl of the unit as shown so that the face of the mirror is visible.
Ensure the datum mount is fully home on the cowling.
- (b) Undo the latches on the alignment telescope's mounting latch assembly and rotate the assembly so that the parallel support bar fits underneath the unit as indicated by arrow 2.

3. INSTALLATION AND OPERATION

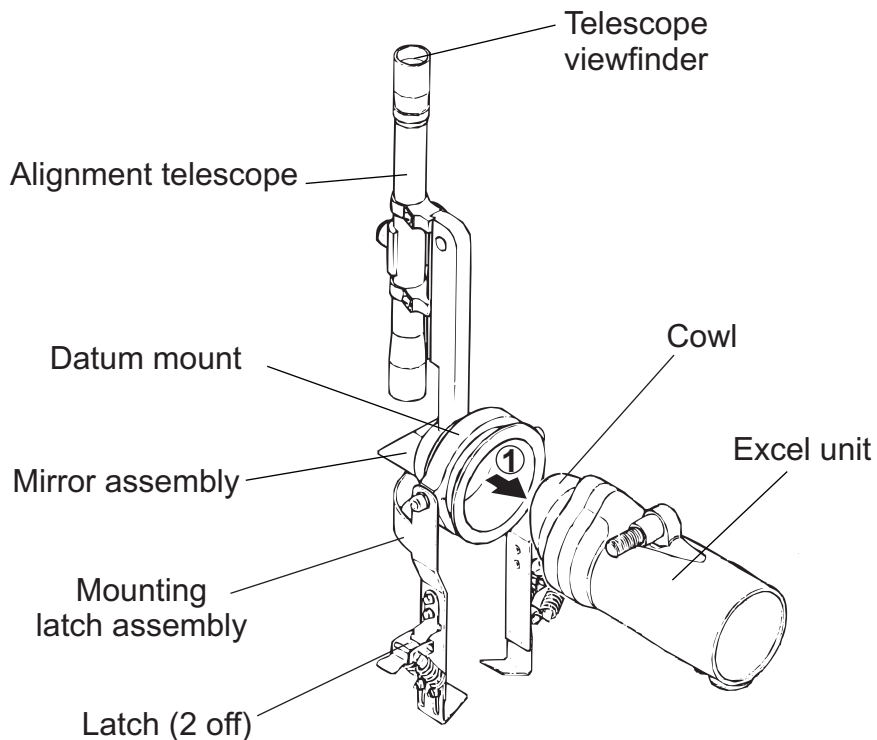

- (c) Locate the latch mounting hooks behind the back of the unit.

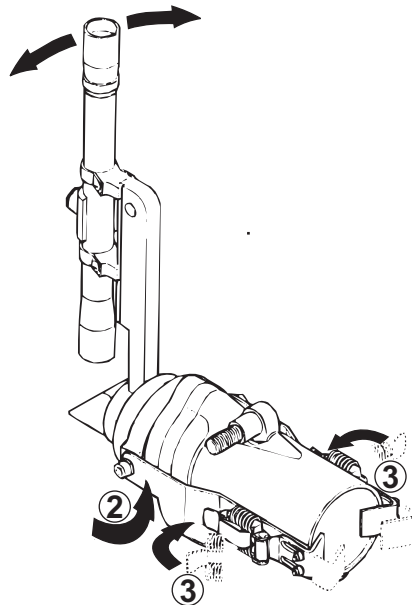

- (d) Rotate the telescope to a comfortable viewing position, and then secure the latches as indicated by arrow 3.

A horizontal viewing position is the easiest to interpret.

Now align the units by continuing with step 5.

3. INSTALLATION AND OPERATION

Bayonet-style Trident-type telescope assembly

Caution: *This type of telescope assembly must only be used with Trident-type Excel units.*

This type of telescope assembly consists of a telescope and mirror attached to a datum mount. The mount features a bayonet fitting for attaching the assembly to the Excel unit.

The datum mount has a handle for rotating and locking the whole assembly over the cowl and onto the Excel unit's body.

Before tightening the datum mount the telescope can be rotated to a convenient viewing position. To remove the telescope assembly reverse the following mounting procedure.

- (a) Align the telescope's two datum mount bayonet slots with the two locating pins on the cowl of the unit as shown.

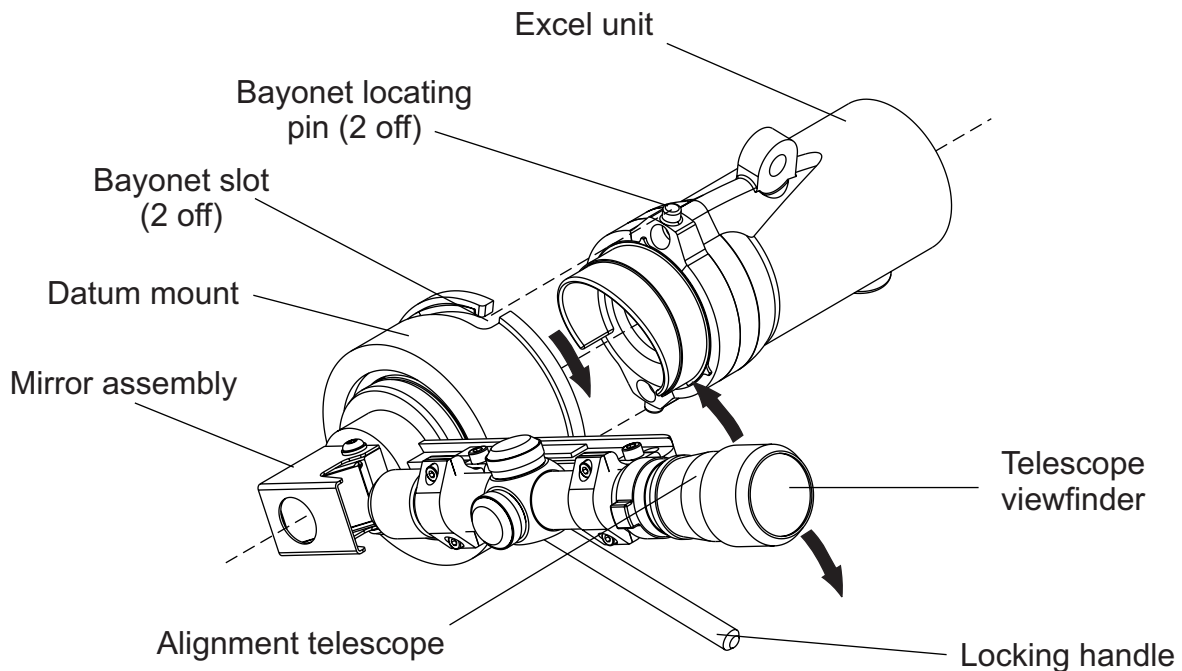

- (b) Push the telescope datum mount fully home onto the two pins on the cowl.
- (c) Without disturbing the datum mount use one hand to rotate the telescope to a comfortable viewing position and hold it in that position.
A horizontal viewing position is the easiest to interpret.

3. INSTALLATION AND OPERATION

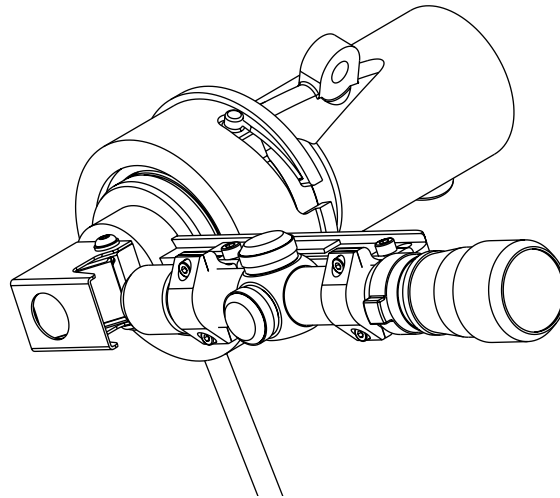

- (d) With the other hand use the datum mount's locking handle to rotate the bayonet fitting in a clockwise direction until it is securely locked onto the cowl. *The fitting is held tightly against the face of the cowl by means of hidden compression springs.*

After attaching the telescope assembly align the units by continuing with step 5.

- (5) Align the Excel unit using the two sets of assembly adjustment screws so that the cross-hairs viewed through the alignment telescope are centred on the window of the other Excel unit.

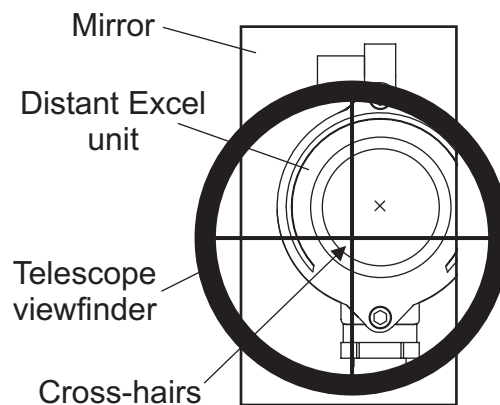

Before alignment

View the image with the eye placed approximately 3 inches from the viewfinder.

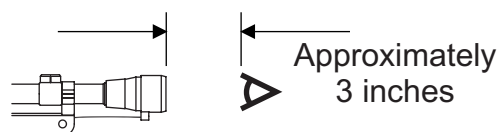

3. INSTALLATION AND OPERATION

Use a viewing position that ensures that the full circular view is in sight. An ellipse will appear when slightly off axis.

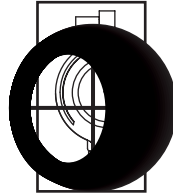

Off-axis view

Caution: Do not try to adjust the cross-hairs using the telescope's elevation and windage adjusters as they have been factory set.

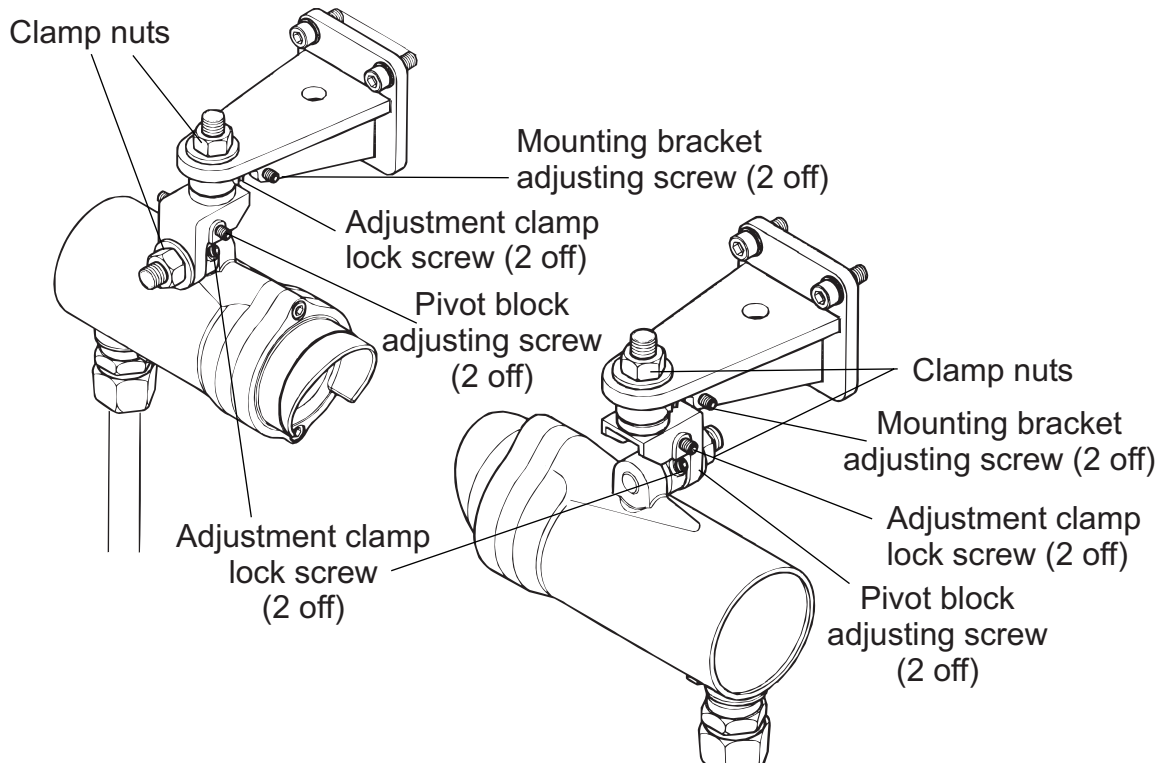

- (6) Iteratively tighten and loosen each pair of adjustment screws sequentially in the horizontal and vertical directions until the setting is correct.

3. INSTALLATION AND OPERATION

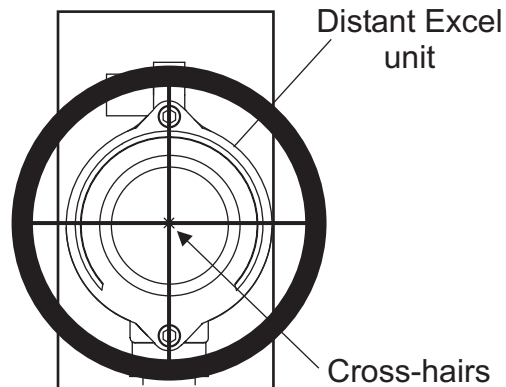

After alignment

- (7) When correctly adjusted, tighten both adjustment screws simultaneously. Ensure there is minimum movement whilst locking the assembly.
- (8) Check alignment and repeat steps 5 to 7 as necessary.
- (9) Remove the telescope assembly from the unit by reversing the fitting instructions.
- (10) Carry out the final commissioning procedures described in the next sub-section.

3.7.5 Commissioning the Gas Detector

This process consists of the following steps:

- **Connect the Handheld Interrogator to the gas detector**
- **Power-up the gas detector and check/set the mode of the Interrogator for operation with the installed Excel gas detector**
- **Set the gas detector real-time clock**
- **Complete the alignment process**
- **Finish up**

Connecting the Interrogator

Connect the SHC1 Handheld Interrogator to the gas detector in one of the following ways:

- via a Zellweger Analytics DVC100/DX100/DX100 (M) Junction Box - connect the Interrogator directly to the junction box via its IS socket, e.g.

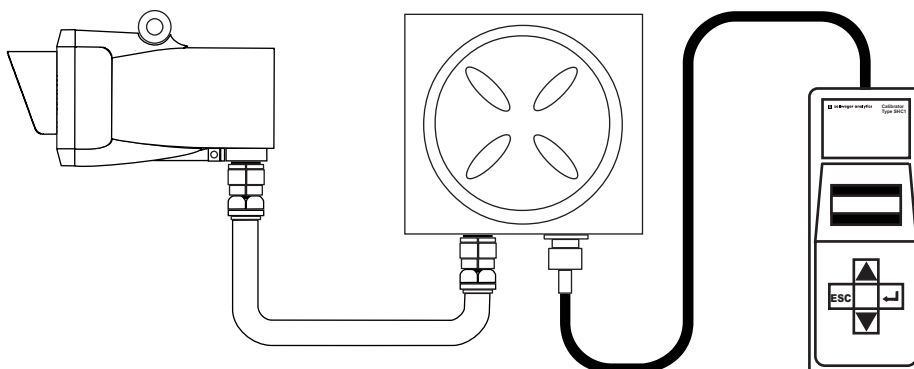

3. INSTALLATION AND OPERATION

- via another type of junction box, e.g. Hawke PL612 - using the SHC Protection Device.

See the following diagram and description and **Appendix C - Spare Parts**.

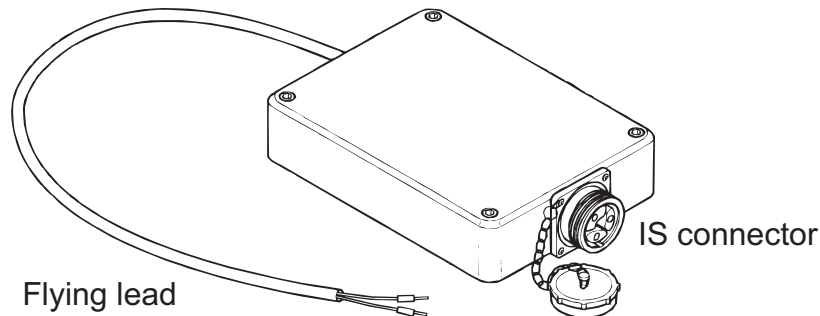

Notes:

1. The protection device must always be used for this type of connection.
2. A hot work permit may be required for this procedure.

Carry out the following procedure to connect using the protection device.:

- (1) Isolate all power supplies.
- (2) Remove the cover of the junction box.
- (3) Hard wire the flying lead of the SHC Protection Device to the communications link terminals in the box as shown:

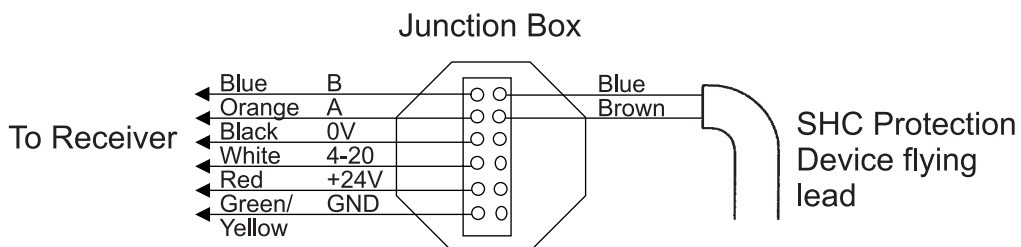

- (4) Connect the Interrogator to the IS connector on the end of the SHC Protection Device.

Powering Up

- (1) Apply power to the Excel Transmitter and Receiver units.
- (2) Press and hold the **↵ (Enter)** key on the Interrogator keypad for at least two seconds.

3. INSTALLATION AND OPERATION

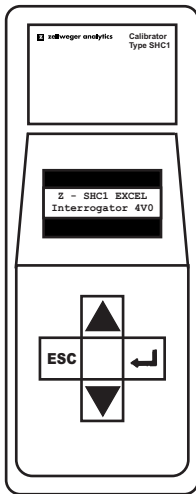

This switches on the unit.

Note: Full details of the SHC1 Handheld Interrogator can be found in Appendix A.

The Interrogator displays the following start-up message for approximately three seconds:

Z - SHC1 EXCEL Interrogator 4V0

- Quickly check the type of connected detector shown on the top line of the message.
*The display shows **Excel** or **Optima+** or **Optima**.*
- If the unit displays **Optima+** or **Optima** immediately press the **ESC** key on the keypad.
*The **ESC** key must be pressed within 3 seconds to have any effect. Also see Appendix A, section 5.6.*

*This toggles the Interrogator mode between **Excel**, **Optima Plus** and **Optima**.*

*The start-up message is updated and displayed again for 3 seconds then the unit displays the **Main** menu, which is the top level of its Interrogator's menu style interface, as follows:*

^	Main	v
	Display	

The first line of the display shows the current level in the menu tree and the second line displays a sub-menu title, action or data.

Setting the Real-Time Clock

The gas detector clock needs to be initially set so that faults, events, etc., can be accurately recorded and tracked for diagnostic purposes.

- Select **Calibrate** from the **Main** menu by pressing the ▲ (**up**) and ▼ (**down**) keys on the keypad to navigate through the menu options.
- Press ↵ (**Enter**) on the Interrogator keypad to display the **Calibrate** menu.
- Select **Set Time/Date** from the **Calibrate** menu.

3. INSTALLATION AND OPERATION

- (4) Press **Enter** on the keypad and an initial set time display similar to the following appears:

Time 09:26		
^	09	v

The top line shows the current time and the second line shows the new hours setting.

- (5) Set the hour using the up and down keys on the keypad.
(6) Press **Enter** on the keypad and the new minutes setting is now displayed on the second line.

Time 09:26		
^	09:26	v

- (7) Set the minutes using the up and down keys on the keypad.
(8) Press **Enter** on the keypad and the display for setting the date now appears as follows:

Date 20APR03		
^	20	v

The second line shows the new day setting.

- (9) Set the day using the up and down keys on the keypad.
(10) Press **Enter** on the keypad and the new month setting is then displayed.
(11) Repeat the procedure to set the month and year.
(12) When complete press **Enter** on the keypad to return to the **Calibrate** menu.

Notes:

1. *The time and date will not be updated unless both are entered and accepted without error.*
2. *Pressing **ESC** on the keypad at any time, aborts the current setting immediately and returns to the previous setting or menu option.*

Complete the alignment process

In this part of the procedure details about the gas detector must be entered so that the Interrogator can then complete the commissioning of the gas detector using the correct data.

- (1) Select **Calibrate** from the **Main** menu.
Press the up and down keys on the keypad to navigate through the menu options.
- (2) Press **Enter** on the Interrogator keypad.
*This displays the **Calibrate** menu.*
- (3) Select **Install** from the **Calibrate** menu.
- (4) Press **Enter** on the keypad.

3. INSTALLATION AND OPERATION

The following is displayed:

System Type Shrt Range

The second line shows the current gas detector type:

Short Range	5 - 40m	(15 - 130ft)
Medium Range	20 - 120m	(65 - 390ft)
Long Range	20 - 200m	(65 - 650ft)

- (6) Press **Enter** on the keypad.

The current path length setting in metres similar to the following is now displayed.

Path Length
^ 09:26 v

- (7) Set the actual path distance (measured in metres) between the Transmitter and Receiver units, using the up and down keys on the keypad.

The minimum and maximum path length entry options for each gas detector are:

Gas Detector Type	Minimum Range (m)	Maximum Range (m)	Step Size (m)
40m Range	5	40	1
120m Range	20	120	1
200m Range	20	200	1

- (9) When finished press **Enter** on the keypad.

A self-test routine is started and the display shows the following message:

Self Test Please Wait
--

When the test is successfully finished the following message is displayed for at least three seconds:

Checks Passed

The screen then changes to show a display similar to the following.

SIG: █
TGT: █

The first line of the display shows the magnitude of the current **signal** level as a horizontal bar graph - **SIG:**

The second line of the display shows the magnitude of the current **target** signal level as a horizontal bar graph - **TGT:**

3. INSTALLATION AND OPERATION

Important Notes:

- 1) *The overall objective of alignment is to maximise the **SIG** level. Maximised **SIG** corresponds to optimal alignment.*
- 2) *The Instrument Assisted Alignment (IAA) system only allows Excel to be initialised if the **SIG** level is greater than or equal to the **TGT** level when **Enter** is pressed.*
- 3) *The smallest **TGT** signal level that is initially set will be equivalent to 70% (0.700) of the signal expected for the installation's path length.*
- 4) *The **TGT** level will increase gradually if the current **SIG** level is larger than the **TGT** level. The **TGT** signal level only ever increases. If the current **SIG** level falls below the **TGT** level, **TGT** will remain at its previous highest value. In order to initialise the gas detector the **SIG** level must be brought back above the **TGT** level.*
- 5) *If the **SIG** level is less than 50% of the expected level, the bar graphs are **not** displayed. Instead both **SIG** and **TGT** levels are displayed as **numbers**.*
- (10) Now carry out one of the procedures described under **Options**.

Options

The next procedure to be followed depends on the type of alignment telescope and mounting initially used to set up the Excel gas detector.

Bayonet-style Trident-type telescope assembly

If this type of alignment telescope was used with a Trident-type Excel gas detector, there is no need to further optimise the alignment using the SHC1 Handheld Interrogator.

When the **SIG** and **TGT** bar graphs are displayed on the SHC1 screen, **SIG** will always be greater than **TGT** and installation can proceed to the next stage by pressing **Enter** and following step 12.

Latch-style Trident-type telescope assembly

If this type of alignment telescope was used with a Trident-type Excel gas detector, there is no need to further optimise the alignment using the SHC1 Handheld Interrogator.

If this type of alignment telescope was used with a non-Trident Excel it may be necessary to further optimise the alignment in the following way in order to achieve best performance.

- (a) After the **SIG** and **TGT** bar graphs are displayed on the SHC1 screen as previously described, let the **TGT** level reach its initial maximum by waiting for approximately 10 seconds.

*During this time the **TGT** level will move up towards the current **SIG** level.*

- (b) Whilst watching the **SIG** level closely, make a **small** mechanical adjustment in either the horizontal or vertical alignment and note whether the **SIG** level goes up or down.
- (c) If the **SIG** level goes **up**, make another **small** mechanical adjustment in the same direction as before.
- (d) If the **SIG** level goes **down**, change the direction of adjustment.

*Maximise the **SIG** level by making **small** adjustments in only **one plane** at a time.*

3. INSTALLATION AND OPERATION

- (e) When the **SIG** level has been maximised in one plane, make small adjustments in the other plane until **SIG** has been maximised in this plane.
- (f) Repeat steps (b) to (e) until the **SIG** level has been maximised in both planes.
*At this point, **SIG** must be bigger than the initial **TGT** level and any adjustment either side of the current alignment must result in a reduction in signal level.
If not, repeat steps (b) to (e) until these requirements have been met.*
- (g) Lock off the alignment by placing a hex (Allen) key in the pair of grub-screws which control adjustment in a particular plane and simultaneously rotating them in opposite directions.
- (h) Repeat this for the other pair of grub-screws.
- (i) Press **Enter** and the signal levels are checked.
*With the **SIG** level is greater than the **TGT** level, the signal check should pass and the screen should display the following message:*

Signals OK

Notes:

1. If **SIG** is less than the **TGT** value the following message is displayed:

Low Signal
Enter to Retry

2. If **SIG** is more than the **TGT** value the screen shows the bar graph screen again.

- (12) When the following message is displayed press Enter:

Signals OK

The display changes to show the following instruction:

Ensure Zero Gas
Then Press Enter

Ensure there is a gas-free atmosphere.

- (13) Press **Enter** on the keypad.

The following message is displayed for three seconds:

Zero Calibration
OK

The following message is displayed for three seconds:

Installation
Complete

3. INSTALLATION AND OPERATION

The following message is then displayed:

Press Enter to
Release 4-20

- (14) Press **Enter** on the keypad.

The following message is displayed for three seconds:

4-20 Released

The display then changes to show the **Calibrate** menu. The Searchline Excel gas detector is now **live**.

This completes the final part of the gas detector alignment procedure.

3.7.6 Finishing Up

To finish the alignment process carry out the following procedure:

- (1) Select **Power Off** from the Interrogator **Main** menu.
- (2) Press **↵** (**Enter**) on the keypad.
*Alternatively press the **↵** and **ESC** buttons simultaneously for a fast power off.*

Notes:

1. The SHC1 Handheld Interrogator powers down automatically after five minutes of non-use.
2. Fast power off and auto power off are disabled when any menu option is selected that modifies the unit's configuration.
- (3) Disconnect the Interrogator from the gas detector, reversing the process described at the beginning of section 3.7.5.

3.8 SYSTEM CONTROLLER CALIBRATION

This procedure is used to set up the system controller using the Searchline Excel gas detector. A chosen fixed output signal is sent from the Excel gas detector to the system controller allowing calibration of the 0 - 100% scale of the controller without having to use gas. The steps use procedures described in the previous section.

To calibrate the controller carry out the following procedure:

- (1) Connect the Interrogator to the gas detector.
*See **Connecting the Interrogator to Searchline Excel Gas Detector**.*
- (2) Turn on the Interrogator.
*See **Powering Up**.*
- (3) Select **Calibrate** from the main menu.
Press the up and down keys on the keypad to navigate through the menu options.
- (4) Press **Enter** on the Interrogator keypad and the **Calibrate** menu is displayed.
- (5) Select **Force 4-20** from the **Calibrate** menu.

3. INSTALLATION AND OPERATION

- (6) Press **Enter** on the keypad and a display similar to the following appears:

4-20 current		
Λ	4.5 mA	V

- (7) Use the up and down keys on the keypad to set the displayed output current to the desired value.
The values can be changed in steps of 0.1mA in the range 1mA to 21mA.
- (8) Press **Enter** on the keypad.

This selects the currently displayed value and forces the gas detector to output that current. Once complete a display similar to the following appears:

Fixed:4-20 mA	
Press Enter	

- (9) Carry out checks on the controller by following the instructions in the controller documentation.
- (10) When checks are complete press **↵** on the Interrogator keypad and the following display appears:

Press Enter To	
Release 4-20	

- (11) Press **Enter** on the keypad.
The following message is displayed:

4-20 Released	
---------------	--

The fixed output is released and the gas detector returns to normal operation.

- (12) Turn off the Interrogator and disconnect it from the gas detector.

3.9 INSTALLATION CHECKS/TESTS

The following information is for the guidance of personnel carrying out installation checks/tests on Searchline Excel. In general it should be noted that:

- Searchline Excel should only be installed by fully trained personnel, trained by Zellweger Analytics or an authorised Zellweger Analytics trainer.
- Detailed information concerning installation, alignment and commissioning is provided in this Technical Handbook.
- Searchline Excel is explosion protected by a certified, flameproof enclosure. Carefully read the safety warnings, cautions and certification details in this handbook and the Basic Installation Guide.
Ensure that they have been complied with, before and during the installation.
- A copy of the subsequent **Installation Check Sheet** should be completed for each Searchline Excel gas detector installed. In order to help Zellweger Analytics to provide efficient assistance/service in the event of problems, the sheet should be returned to Zellweger Analytics or to one of their agents.

3. INSTALLATION AND OPERATION

SEARCHLINE EXCEL: INSTALLATION CHECK SHEET					2104P1003	
CUSTOMER/OPERATOR						
SITE / FACILITY						
SYSTEM TYPE:	SR	MR	LR	OPERATING RANGE		
GAS TABLE:	METHANE	ETHANE	PROPANE	BUTANE	ETHYLENE	
PROPYLENE	BUTADIENE	PENTANE	HEXANE	PROPYLENE	OTHER	
DETECTOR LOCATION:						
TAG NO. (RX):			TAG NO. (TX):			
SER NO. (RX):			SER NO. (TX):			
MOD STATE (RX):		MOD STATE (TX)		CERTIFICATION:		
CHECK/TEST		RECEIVER		CHECK/TEST		TRANSMITTER
Mount Rigidity				Mount Rigidity		
Vibration:				Vibration:		
Excess heat:				Excess Heat:		
Supply Voltage:				Supply Voltage		
Earthing:				Earthing:		
RFI/EMC				RFI/EMC		
Contaminants:				Contaminants:		
BEAM OBSTRUCTIONS / BLOCKS:						
(cont.)						
TEST FILTER:	LEL .m	Response :		LEL.m	Pass:	Fail:
4-200 mA LOOP INTEGRITY	Pass:	Fail:			Untested:	
FAULT / WARNING LOG:	Clear:	Faults / Warnings:				
(cont.)						
INSTALLATION SATISFACTORY:		Yes:	No:	SIGNED:		
INSTALLED BY (PRINT)			DATE:			
IF INSTALLATION UNSATISFACTORY, REASONS						
RECOMMENDATIONS						
				CUSTOMER NOTIFIED:		
SYSTEM STATUS:	Operational:		Non operational:			

3. INSTALLATION AND OPERATION

The following notes are to help the installer enter the correct information onto the check sheet.

Site/Facility

Enter the name and geographical location of the site/facility, e.g.

NAM F3 Platform, North Sea

Operating Range

Enter the distance (preferably in metres), between the Transmitter and the Receiver.

Detector Location

Enter the location/position of the detector, e.g.

West Corridor, HIVAC Building1

Tag No

Enter the **Tag No**, or equivalent, that has been allocated to the Excel Receiver and Transmitter units.

Mod State

Enter the **Mod State** of the units as indicated on their certification/product labels.

Certification

Enter the certification of the units, e.g.

CENELEC, UL, CSA, FM

Mount Rigidity

Check that the units have been mounted securely to the supporting structure. Check that the supporting structure is sufficiently rigid to maintain alignment in the anticipated operating conditions. A maximum angular movement of $\pm 0.5^\circ$ is allowable.

As an approximate guideline, a sufficiently rigid mount/supporting structure will only move a few millimetres (not more than $\pm 6\text{mm}$) when leaning body weight against it.

When pushed hard and released, the mount/supporting structure should return quickly to its original position and should not wobble or sway. If the mount/ support is unacceptable, briefly describe the problem, e.g.

***Mount wobbles unacceptably,
Mounting pole too thin***

Vibration

Check the installation and its close surrounds for potential or existing sources of excessive vibration. Such sources could include heavy plant/machinery, turbines, generators etc.

3. INSTALLATION AND OPERATION

If there is the possibility that such vibration sources could or are causing unacceptable movement, enter a brief description, e.g.

***Turbine nearby,
Below conveyor***

Excess Heat

Check the installation and its surrounds for potential sources of excessive heat. The unit is specified up to +65°C. Potential sources of excessive heat include direct sunlight in hot climates, flare-stacks, generator/turbine exhausts and steam vents.

Enter a brief description, e.g.

***Direct sun, Kuwait,
Flare-stack 2 metres away***

Supply Voltage

Check that the supply voltage applied to the unit is within the specified 18V to 32V range and is stable. Enter the supply voltage and stability, e.g.

***22.5V, stable,
19V, ±2V fluctuation***

Earthing

Inspect the earth connections to the units. If the unit is connected to local metalwork or the safety/general use earth, enter 'Local Safety. If the unit has been isolated from local metalwork/earths and is connected to a clean, instrument earth, enter ***Instrument earth***. (See section 3.3, **Electrical Connections**).

RFI/EMC

Assess the installation, cabling and its close surrounds for known/potential sources of excessive RF/Electromagnetic Interference. Such sources could include radio/radar transmission antennae, high voltage switch-gear, large electrical generators/motors etc.

Searchline Excel is extremely immune to RFI/EMI, complying with the most stringent requirements specified in EN50082-2. It is therefore more likely that the field cabling will pick up interference directly on the 4 - 20mA and 0V connections and that this will affect the reading received at the control room.

Enter brief details of known/potential EMI sources that are within five metres of the gas detector and/or its cabling. If cable is unscreened or inadequately protected, note concerns.

Examples of the sort of information to enter are:

***10m cable, unscreened, Radar, 2m from Receiver,
Cable routed over 400kW generator***

(See section 3.3 **Electrical Connections**).

3. INSTALLATION AND OPERATION

Contaminants

Assess the installation and its surrounds for sources of contaminants that could build up on the unit's windows. Such contaminants could include oil mist, heavy sea spray, drilling mud, dirty exhaust fumes, wave splash etc.

If there is a realistic possibility that such contaminants could cause a significant problem, enter a brief description, e.g.

***Drilling mud spray,
Diesel generator exhaust***

Beam Obstruction/Blocks

Ideally, a clear path of at least **20cm** diameter should be provided between the Transmitter and the Receiver. Enter any obstructions which encroach into this path, e.g.

***Process pipes,
Tree branches***

Assess the installation and the beam path for potential sources of beam blockage. These could include personnel walking in the beam, parking vehicles, moving machinery/plant, growing vegetation etc.

If there is a realistic possibility that they could cause a significant problem, enter a brief description, e.g.

***Personnel in corridor,
Loading bay vehicles***

Test Filter

After completing the installation procedure, enter the **DISPLAY** mode and test the gas detector response with a plastic test filter. Enter the nominal value of the test filter, the unit's displayed response and mark the **Pass** or **Fail** box.

The acceptable responses to test filters for different gas tables are detailed in section 5.1.2.

4 - 20mA Loop Integrity

Test the 4 - 20mA loop integrity by forcing the unit to output a known current and monitoring this at the control room or with a multimeter inserted into the loop. Mark the appropriate box.

Fault/Warning Log

Check the fault/warning log. In order for the unit to complete installation satisfactorily, the **ACTIVE FAULTS** log must be **CLEAR**. Use the Handheld Interrogator to diagnose and remedy all **ACTIVE FAULT**.

Wherever possible, it is recommended to **CLEAR** any **ACTIVE WARNINGS**, since these may lead to faults in the future.

3. INSTALLATION AND OPERATION

Faults/Warning

Enter any **ACTIVE FAULTS** or **ACTIVE WARNINGS** that could not be cleared from the log, e.g.

**BEAM BLOCK,
E_ZERO_NOT_CALIBRATED**

Installation Satisfactory

Only fully trained personnel trained by Zellweger Analytics or Zellweger Analytics authorised trainers can declare an installation satisfactory. Mark the **YES** box and sign the form if:

- a. having completed the installation and testing, the unit is operating correctly, and
- b. in the trained installer's opinion, the unit should continue to operate reliably in this installation/operating environment providing that nothing significant about the installation/environment is changed.

If the unit is **not** operating correctly or there are aspects of the installation/operating environment which in the trained installer's opinion could or will result in unreliable operation, mark the **NO** box.

Reasons for declaring an installation unsatisfactory could include:

***excessive movement/vibration of unit's mounting,
received signal levels too low,
supply voltage too low,
4 - 20mA loop integrity faults,
unclearable active faults,
any prevailing or probable condition which is known to unacceptably reduce
reliability or availability***

If Installation is Unsatisfactory, Reasons

Briefly state the principal reasons why the installation is unsatisfactory, e.g.

***Unit mounted on single scaffold pole. Excessive movement,
Beam path obscured by pipes, insufficient received signal levels,
Unit overheated by intense Kuwaiti sunlight***

Recommendations

Briefly describe the recommended actions which need to be performed in order to make the installation satisfactory, e.g.

***Mounting pole requires bracing/stiffening,
Pipes obscuring beam to be moved, or detector relocated.
Provide correct supply voltage***

3. INSTALLATION AND OPERATION

Customer Notified

Make sure that the relevant customer/operator is notified of the installation problem(s). Mark box accordingly.

System Status

Upon leaving, note the gas detectors status, i.e. operational or nonoperational.

4. CROSS-DUCT EXCEL

4.1 INTRODUCTION

The Cross-Duct version of Searchline Excel gas detector is designed for applications where the path to be monitored is between 0.5 and 5 metres. It operates on the same principle as the Open-Path Excel, but instead of having the Transmitter and Receiver at opposite ends of the path, they are both located on the same mounting plate.

NOTE: THE INFRARED BEAM IS INVISIBLE AND EYE SAFE.

A retro-reflector at the opposite side of the duct directs the beam from the Transmitter back towards the Receiver. Most of the details for operation of the Open-Path Excel apply to the Cross-Duct version. The following sections highlight the differences.

4.2 GAS DETECTOR DESCRIPTION

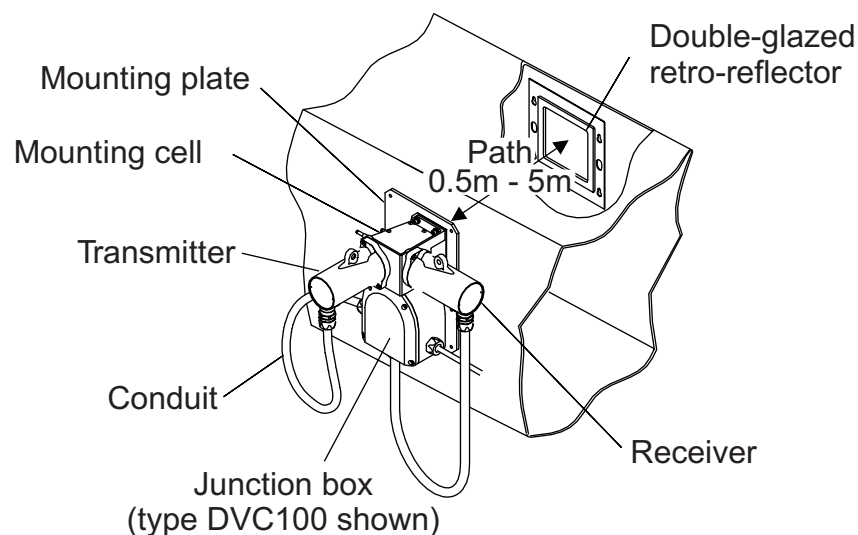

The Cross-Duct Searchline Excel gas detector consists of a Transmitter and Receiver, which are fixed to a mounting block, and a separate retro-reflector. The Transmitter and Receiver are mounted on a cast metal block (mounting cell) that houses a beamsplitter, and incorporates a gassing cell for functional testing purposes.

The Receiver is the same as the standard Open-Path version, but the Transmitter uses a different design, which gives a uniform intensity across the beam at the shorter path lengths.

There are two variants of the Cross-Duct Excel, which differ in the ranges over which they operate. These are:

Short Range	0.5 — 2.5m	(20in — 8ft)
Long Range	2.5 — 5m	(8ft — 15ft)

The long range gas detector uses a large retro-reflector, which is twice the size of the short range retro-reflector.

4. CROSS-DUCT EXCEL

4.2.1 Transmitter

The Cross-Duct Excel Transmitter produces an intense, collimated infrared beam from a Xenon arc flashlamp. It uses a different optical arrangement compared with the Open-Path Transmitter. This enables it to produce a beam with a uniform intensity distribution even at the shortest operating range.

Note: The infrared beam is invisible and eye safe.

Compared with the standard Transmitter, the Cross-Duct Transmitter has a larger window heater to reduce the possibility of condensation.

4.2.2 Receiver

The internal design of the Receiver is the same as that used in the Open-Path versions of Searchline Excel. Externally the Cross-Duct Receiver has a different front end which fixes onto the mounting cell. In the Cross-Duct version, the gas reading is automatically converted into a %LEL (%LEL/m for FM version) measurement, taking into account the path length and the double pass of the beam across the duct.

4.2.3 Retro-Reflector

Using a retro-reflector panel has a number of advantages for a Cross-Duct gas detector. Because the infrared beam crosses the duct twice, it will be absorbed twice by any gas present. This makes the gas detector more sensitive to gas than a single pass gas detector. Sensitivity to vibration or misalignment is greatly reduced. The retro-reflector can be tilted by up to 15° before the signal starts to drop. Any positional misalignment does not affect the signals as long as the beam stays on the retro-reflector. When installing a Cross-Duct Excel, there is no complex alignment procedure. Provided the retro-panel is mounted opposite the Transmitter and Receiver gas detector, and perpendicular to the beam, the signals will be sufficient for normal operation.

4.3 INSTALLATION AND OPERATION

WARNING

In common with all certified Exd equipment, the Cross-Duct Excel should not be installed where it will experience a pressure differential of more than 2psi. i.e. the air pressure in the duct should not differ from external air pressure by more than 2psi.

4.3.1 Siting and orientation

Position

Although the Cross-Duct Excel has been designed to tolerate the most severe environmental and site conditions, for optimum performance care should be taken to avoid areas where the unit may be affected by:

- **Vibration**
- **Accidental impacts**

4. CROSS-DUCT EXCEL

- **Electrical interference due to proximity of radio or radar antennae**
- **Flooding or frequent wave deluge**
- **Direct heat e.g. from adjacent flare stack, intense sunlight**

Note: The maximum certified operating temperature for Excel is +65°C

- **Contamination build up e.g. oil mist, sea spray, drilling mud, exhaust fumes**

In addition, since the Transmitter and Receiver protrude from the duct wall, adequate precautions should be taken to protect personnel.

To ensure optimum performance, do not cover the Excel with insulation, and allow free air movement around the unit.

Beam Path

The path of the infrared beam is unlikely to be affected by the same obstructions that can affect the Open-Path Excel. However, consideration should be given to avoid:

- **Steam vents**
- **Splash and spray**

Orientation

The Cross-Duct Excel should be mounted on a vertical, flat surface such that the optical axis is horizontal. Although the Excel units will tolerate a certain amount of vibration and misalignment, ensure the surface is rigid and stable. Fit additional supports prior to installation if necessary. The retro reflector should be mounted directly opposite, and perpendicular to the optical axis of the Transmitter/Receiver assembly. If the duct walls are not exactly vertical or parallel, the position of the cut out for the retro panel must be adjusted to compensate. Depending on the duct width, the Cross-Duct Excel will tolerate up to three degrees of angular misalignment of the mounting plate, or 15 degrees tilt of the retro reflector.

It is not advisable to install the Cross-Duct Excel on the top or bottom of the duct. In this orientation the retro panel or the Transmitter/Receiver unit will be susceptible to the build up of contamination.

4.3.2 Electrical connections

The electrical installation of Cross-Duct Excel requires the same care and attention as the Open-Path version. See section 3.3.1 for general precautions. The electrical connections are similar to the Open-Path version of Searchline Excel, but with the Transmitter and Receiver supply being common and connected into the same junction box on the mounting plate.

4.3.3 Power Supply

The Cross-Duct Searchline Excel is designed to be operated from a nominal 24V DC supply. At the Excel units, the supply voltage must be within the range 18 to 32V. The field cabling conductors should have sufficient cross sectional area to ensure that the minimum supply voltage applied to the gas detector is 18V at a current of 720mA.

This corresponds to a maximum round loop impedance of 8.3 ohms for a nominal 24V system supply.

4. CROSS-DUCT EXCEL

The unit maximum power consumption and cable lengths are as follows:

Unit Type	Maximum Power consumption (W)	Maximum cable length (m) with 1.5mm ² conductors (12ohms/km)	Maximum cable length (m) with 2.5mm ² conductors (7.6ohms/km)
Cross-Duct (Transmitter + Receiver)	13	340	540

Notes:

1. The control room supply voltage is assumed to be +24V.
2. All connections along the cable are sound and have zero resistance.

4.3.4 Unpacking

Carefully unpack the equipment, observing any instructions that may be printed on or contained within the packaging.

Check the contents for damage and against the packing note for deficiencies. In the event of damage or loss in transit, notify the carrier and Zellweger Analytics Limited or your local agent immediately. The gas detector consists of the following items:

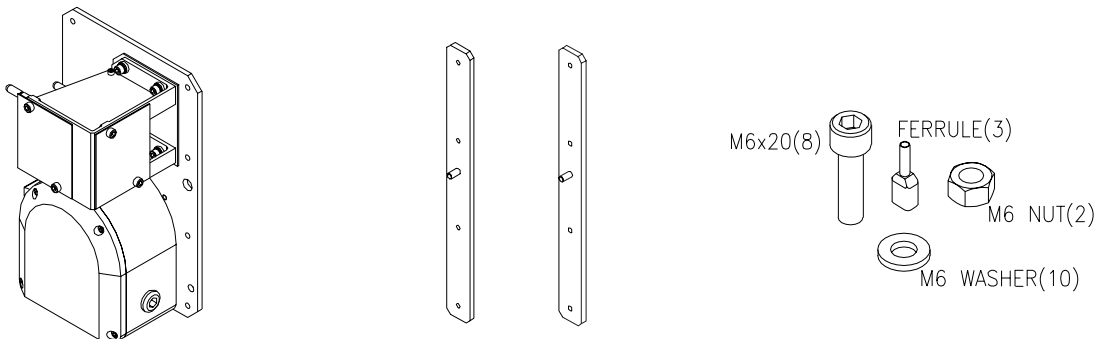

**1 x Mounting Plate, 1 x Mounting Cell
1 x Isolation Kit**

2 x Mounting Straps

Nuts, Bolts & Washers

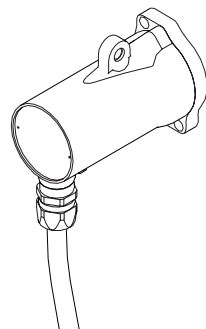

1 x Transmitter

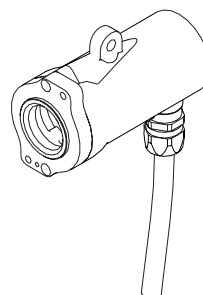

1 x Receiver

4. CROSS-DUCT EXCEL

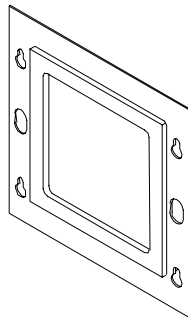

1 x Retro-reflector Panel (Small Panel Shown)

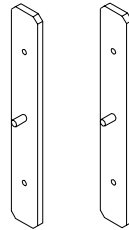

2 x Retro-reflector Mounting Straps (For Small Panel)

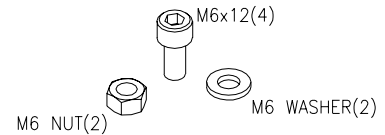

Nuts, Bolts, Washers

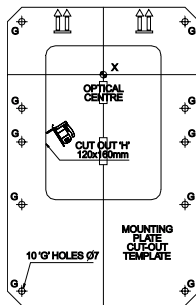

1 x Mounting Plate Cut-out Template

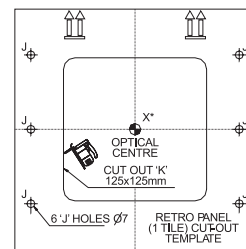

1 x Retro-reflector Panel Cut-out Template (short range shown)

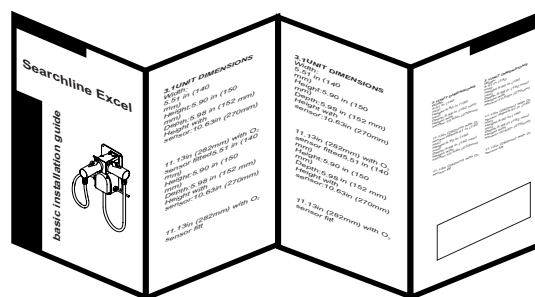

Basic Installation Guide

4.4 INSTALLATION PROCEDURE

Installing the Cross-Duct Excel is done in two stages. First the duct is prepared, and the Excel components mechanically fixed in place. Secondly, the electrical wiring is connected. The Transmitter and Receiver assembly must be fully assembled and mounted to the duct structure before making the electrical connections.

4. CROSS-DUCT EXCEL

4.4.1 Mechanical Installation

Verify that the equipment to be installed is correct for the type of installation required (i.e. short/long range and normal/high temperature.)

Identify the mounting holes using the following drawing and table:

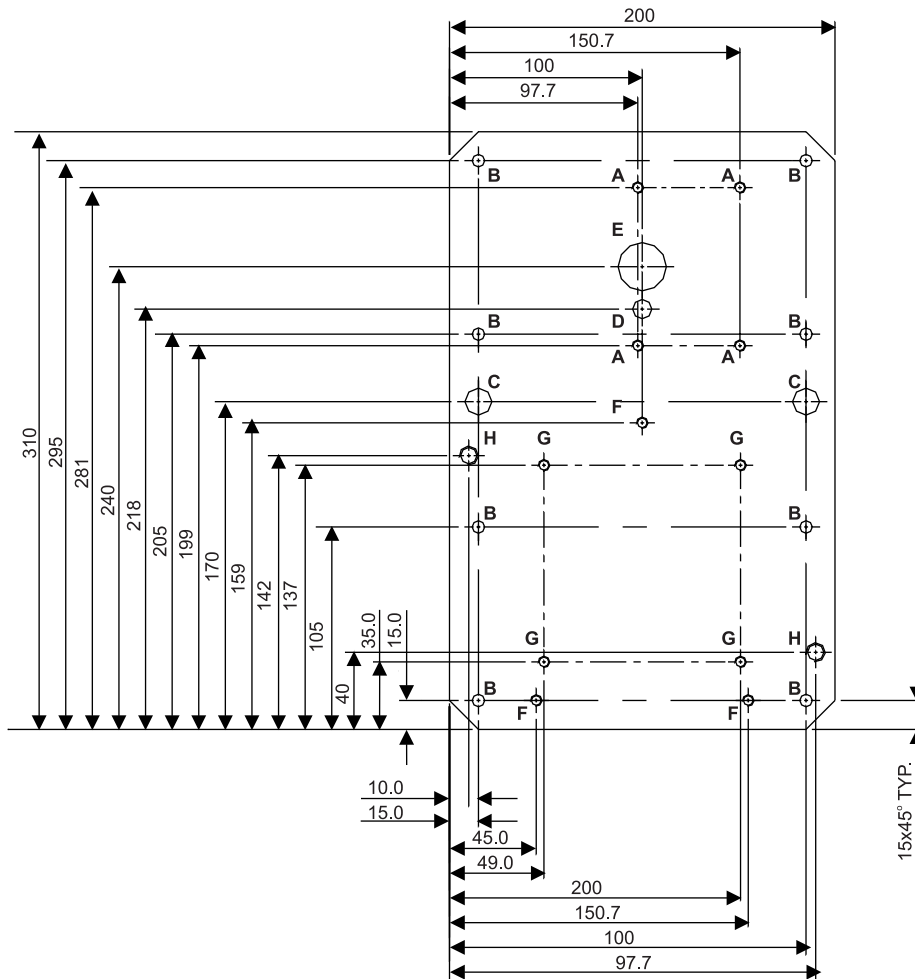

Identity	Quantity	Size	Used for
A	4	M6 tapped	Mounting cell mounting
B	8	Ø 6.5mm	Mounting plate to support bar mounting
C	2	Ø 14mm	Clearance for support bar fixing nuts
D	1	Ø 10mm	Drain for mounting cell
E	1	Ø 25mm	Cross-Duct optical measurement path
F	3	M6 tapped	DVC100 mounting
G	4	M6 tapped	BARTEC terminal box fixing
H	2	M10 tapped	DX100/DX100 (M) fixing

4. CROSS-DUCT EXCEL

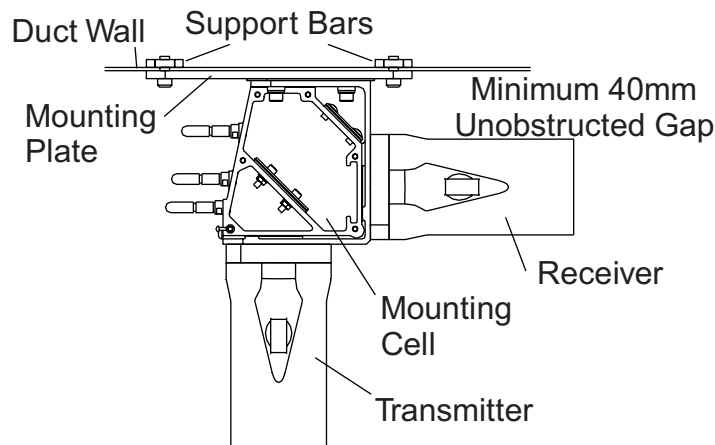

4.4.2 Transmitter and Receiver

- (1) Stick the supplied self-adhesive mounting plate cut-out template onto the duct wall in the position chosen for the Transmitter/Receiver unit.

Note: The intersection of the bold lines on the template (point X) corresponds with the centre of the unit's infrared beam.

- (2) At this stage it is advisable to mark the corresponding position for the retro-reflector on the opposite side of the duct. Stick the retro-reflector cut-out template to the outside of the duct wall opposite the Transmitter/Receiver.

Ensure that point X on the retro-panel template is directly opposite point X on the mounting plate template.

- (3) Drill 10 mounting holes (diameter 7mm) in the positions marked G on the Transmitter/Receiver template.
- (4) Cut a rectangular aperture in the duct wall.

Follow outline H.

- (5) Check that the path from the aperture to the opposite wall of the duct is clear and unobstructed.
- (6) Measure the distance (in metres) across the duct.

Record this distance as it is required later during commissioning.

- (7) One at a time, insert the two mounting plate support bars through the aperture and attach them to the inside of the duct.

Check that the threaded holes in the support bars line up with the holes drilled in the duct. Use M6 nuts and washers.

- (8) Attach the mounting plate, mounting cell and junction box assembly.

Use M6 x 16 cap head screws and washers.

- (9) Remove the blanking plate (thin aluminium sheet) from the right hand face of the mounting cell.
Retain the screws and O-ring.

- (10) Leaving the O-ring in the groove, attach the Receiver unit on the mounting cell.

Ensure its flange is flush with the mounting cell face, and take care not to pinch the O-ring between the mounting surfaces.

4. CROSS-DUCT EXCEL

- (11) Run the Receiver's conduit into the junction box's cable entry.
- (12) Attach the Transmitter to the front face of the mounting cell following steps 10 and 11.

4.4.3 Retro-reflector

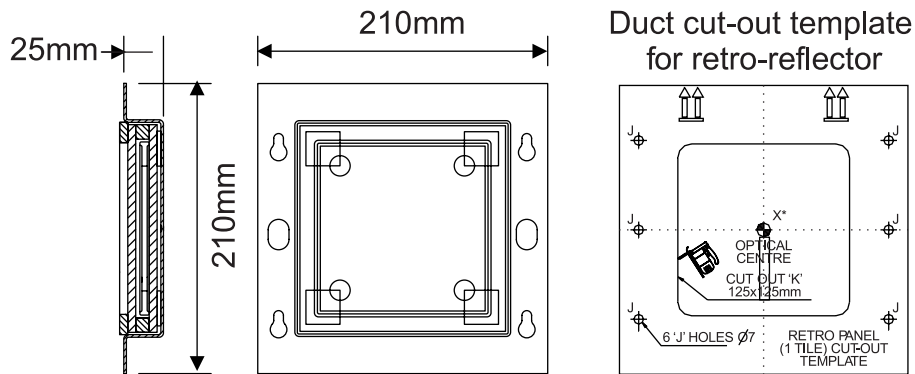

Short range retro-reflector and mounting template

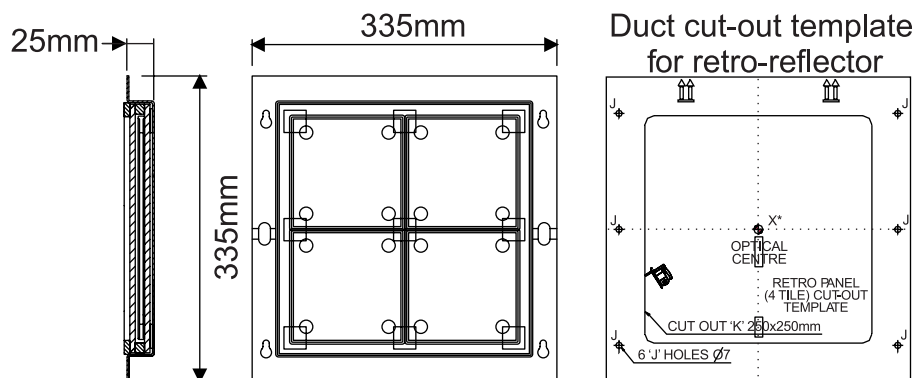

Long Range retro-reflector and mounting template

- (1) If not already in place, stick the retro-reflector cut-out template to the outside of the duct wall opposite the Transmitter/Receiver.
Ensure that point X is directly opposite point X on the mounting plate template. This ensures that the Transmitter's beam hits the centre of the retro-reflector.
- (2) Drill six mounting holes (7mm diameter) in the positions marked **J** on the template.
- (3) Following outline **K**, cut a square aperture in the duct wall.
- (4) Insert the two retro-reflector panel support bars through the aperture and attach them to the inside of the duct.
Check that the threaded holes in the support bars line up with the holes drilled in the duct. Use M6 nuts and washers.
- (5) Fit four M6 x 16 cap head screws into the holes in the support strips leaving approximately 5mm of thread exposed on the outside of the duct.
- (6) Slot the retro-reflector assembly over the heads of the screws and allow its weight to be supported on the exposed sections of thread.
- (7) Tighten the four screws to clamp the retro-reflector assembly in position.

4. CROSS-DUCT EXCEL

4.5 ELECTRICAL INSTALLATION

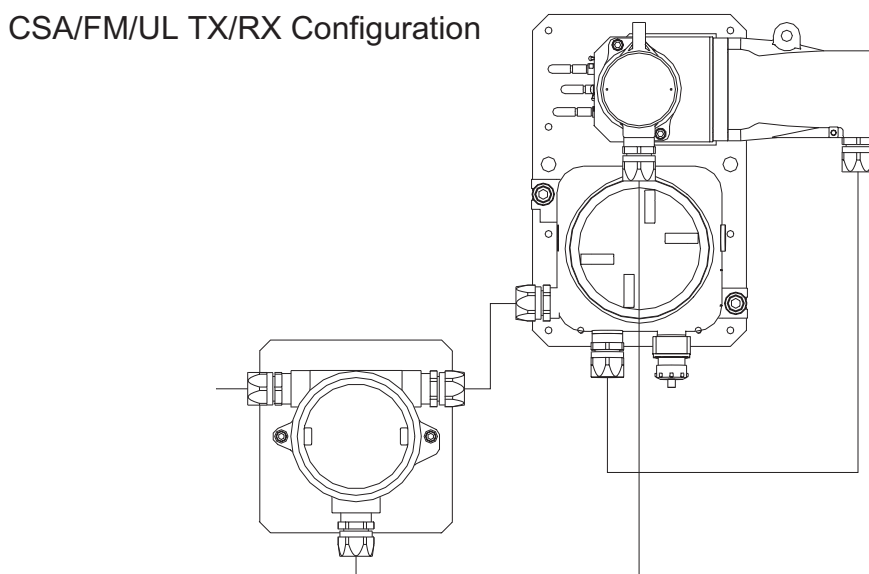
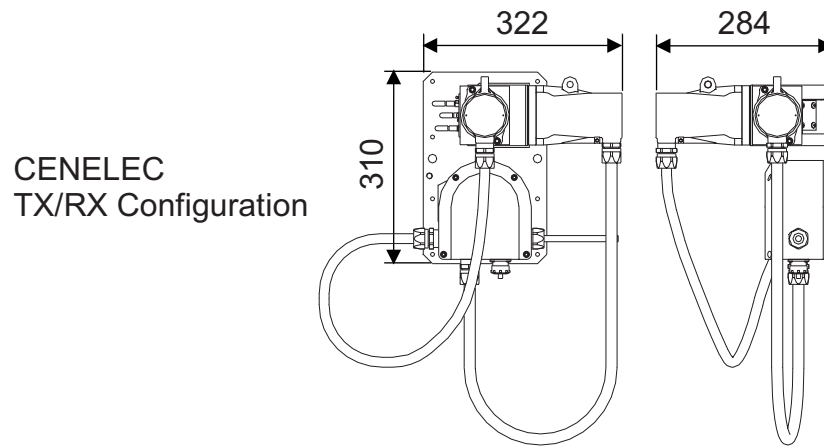

4.5.1 Electrical Installation – Precautions and Recommendations

Consult the recommendations for the Open-Path Excel in section 3.3.1 as they also apply to the Cross-Duct Excel.

Because the Transmitter and Receiver operate from a common supply, the field cabling requirements are different:

For Cross-Duct Excel, the field cabling conductors should have sufficient cross sectional area to ensure that the minimum supply voltage applied to the gas detector is 18V at a current of 720mA. This corresponds to a maximum round loop impedance of 8.3 ohms for a nominal 24V system supply.

4. CROSS-DUCT EXCEL

Installation Procedure

- (1) Isolate all associated power supplies and ensure that they remain **OFF** during this procedure.
- (2) Fit approved cable glands to the junction box cable entries to be used for field wiring.
Use sealing washers where necessary to maintain ingress protection rating.
- (3) Fit approved blanking plugs to all unused cable entries.
- (4) Make appropriate electrical connections as shown in the subsequent diagrams.
- (5) The mounting plate must be bonded to a protective earth, either through contact with the duct wall (if it is itself suitably earthed) or by direct connection.

Note: Suitable crimps or ferrules must be fitted when connecting more than one wire to a single terminal.

4.5.2 Connections using DVC100 Junction Box

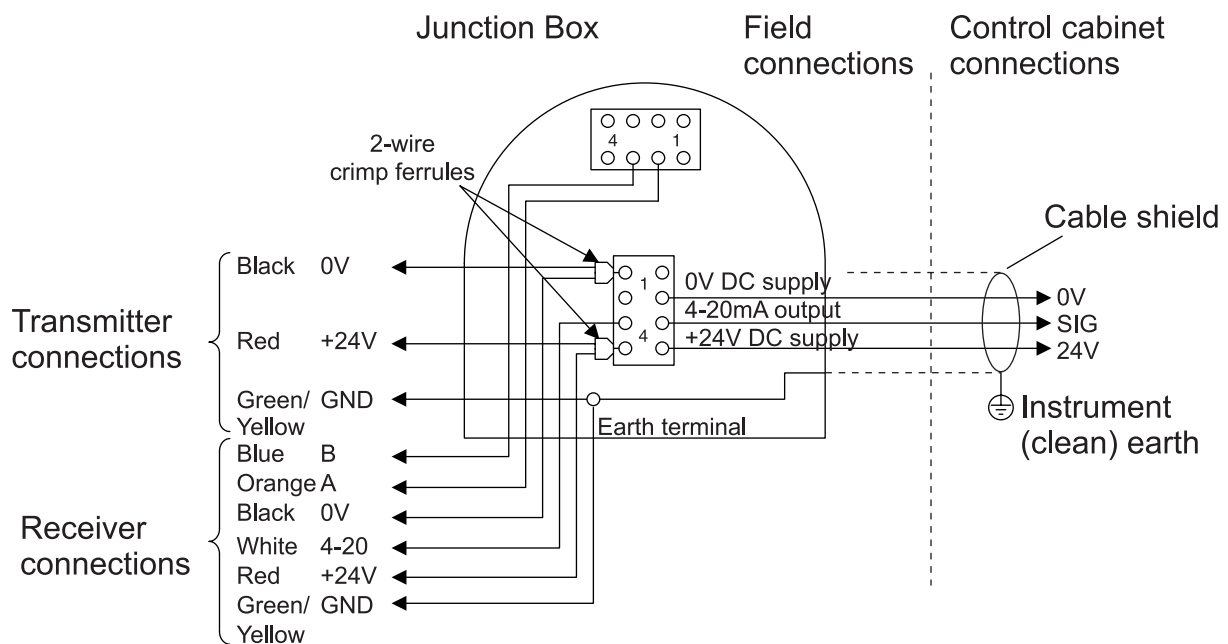

4. CROSS-DUCT EXCEL

4.5.3 Connections using DX100 (M)

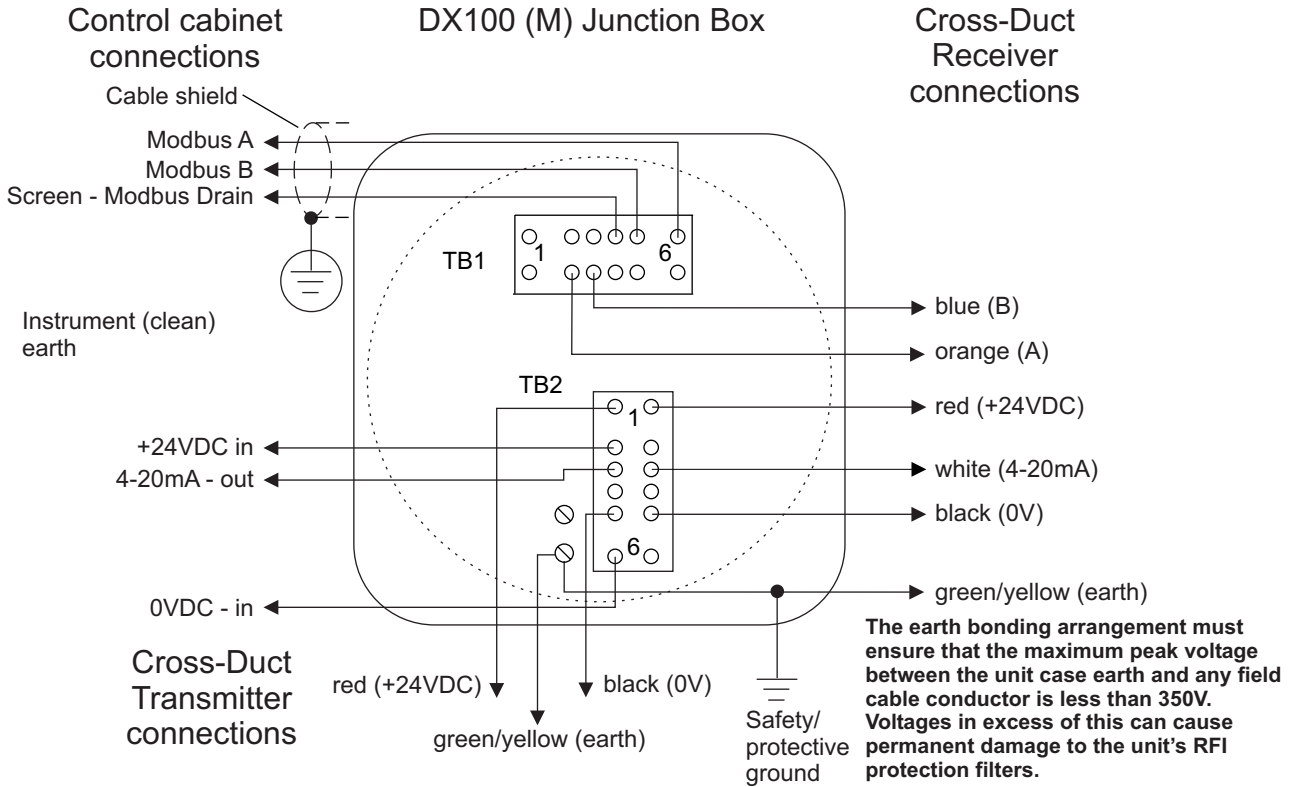

4.5.4 Connections using Non DVC/DX100/DX100 (M) Junction Box

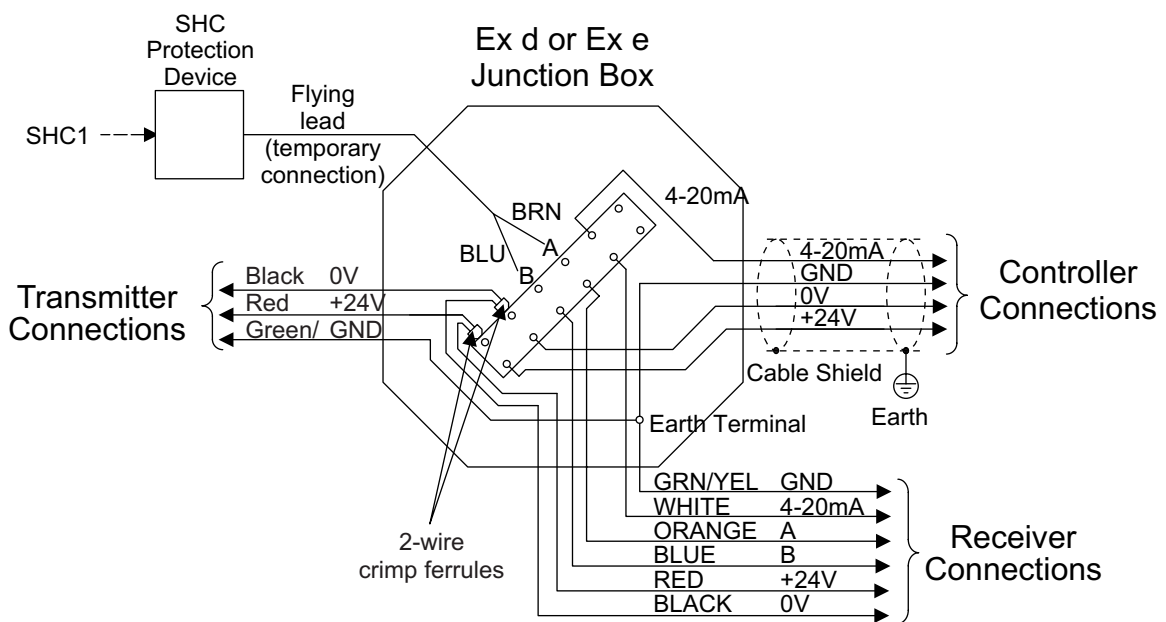

4. CROSS-DUCT EXCEL

4.5.5 Commissioning

This stage is similar to section 3.7.6 for the Open-Path Excel, except that there is no alignment adjustment required for the Cross-Duct Excel.

The commissioning process consists of the following steps:

- **Connect the Handheld Interrogator to the gas detector**
See section 3.7.6.2. Full details of the SHC1 Handheld Interrogator can be found in **Appendix A**.
- **Power up the gas detector and set the interrogator for operation with Excel**
See Section 3.7.6.3.
- **Set the Excel real time clock**
See Section 3.7.6.4.
- **Initialise the Excel gas detector**
See the following section.

4.6 INITIALISING THE EXCEL GAS DETECTOR

- (1) Switch on the Handheld Interrogator.
- (2) Check that the Handheld Interrogator displays **Excel** as the operating mode as it powers up.
*If not, select **CHANGE MODE** from the main menu, and use the ▲ and ▼ keys to select **Excel**.*
- (3) Select **CALIBRATE** from the **Main** menu.
Press the ▲ and ▼ keys on the keypad to navigate through the menu options..
- (4) Press **↵** on the interrogator keypad to display the calibrate menu
- (5) Select **INSTALL** from the calibrate menu.
- (6) Press **↵** on the interrogator keypad and the following is displayed:

System Type		
▲	Duct Mount	▼

The gas detector type cannot be changed.

- (7) Press **↵** on the keypad and the current path length setting in metres is displayed, e.g.

Path Length		
▲	2.5	▼

- (8) Set the path distance (in metres, to the nearest 0.1metre) between the mounting plate and the retro-reflector.

Use the ▲ and ▼ keys on the keypad.

Note: Do not double the distance, enter only the duct width.

4. CROSS-DUCT EXCEL

- (9) Press **↵** on the keypad and the following message is displayed:

Press Enter to
Perform Checks

- (10) Press **↵** on the keypad and the unit now performs a self test check message.
When finished the interrogator displays the following message for at least three seconds:

Checks Passed

The following message is now displayed:

Press Enter to
Align Unit

- (11) Press **↵** on the keypad and the display changes to show the signal magnitude:

SIG: ■
TGT: ■■

No alignment adjustments are provided. If the mechanical installation is satisfactory Excel can be initialised.

- (12) Press **↵** on the keypad and the display shows:

Press Enter to
Initialise Unit

- (13) Press **↵** , and the display will show the following message whilst the unit is initialising:

Processing Data
Please Wait

When the gas detector has completed initialisation, the following message is displayed for three seconds:

Unit Initialised

The display changes to show the calibrate menu and the Searchline Excel gas detector is now live. This completes the commissioning procedure.

If Excel does not initialise, check that:

- the actual duct width agrees with the value entered in step 8 above.
- the reflector panel is clean and fitted securely.

*For further help see **Chapter 6**, Problem Solving.*

4. CROSS-DUCT EXCEL

4.6.1 Disconnecting the Handheld Interrogator

To finish the commissioning process:

- (1) Select the **Power Off** option from the interrogator **Main** menu
- (2) Press **↵** on the keypad
*Alternatively, press the **↵** and **ESC** keys simultaneously for a fast power off.*

Notes:

1. *The SHC1 Handheld Interrogator powers down automatically after five minutes of inactivity in order to preserve battery life.*
2. *The fast power off facility and auto power off are disabled when a menu option is selected that modifies the unit's configuration.*
- (3) Disconnect the interrogator from the Excel gas detector, reversing the steps described in section 3.7.6.

4.7 MAINTENANCE

The Cross-Duct Searchline Excel maintenance requirements are similar to those for the Open-Path gas detector, see **Chapter 5**.

4.7.1 Cleaning

Cleaning procedures are similar to the Open-Path Excel but the beamsplitter in the mounting cell and the retro-reflector may also require cleaning.

To access the Transmitter and Receiver windows, and the beamsplitter:

- Remove the top cover from the mounting cell.
*The cover is retained by 3 x M4 captive bolts, and a chain attaches the lid to the mounting cell when opened. There are no electrical hazards inside the mounting block and a hot work permit is **NOT** required.*

*Note: It is strongly recommended that the Excel gas detector is inhibited (use the Handheld Interrogator and select **Calibrate**, then **Display**) to prevent the unit signalling faults or spurious gas readings which may be caused during cleaning.*

To reduce the need for cleaning, it is possible to connect a supply of compressed air to the **Air Shield** port on the mounting block (see diagram in section 4.7.2). The air shield port is the one closest to the duct. By flowing clean air into the mounting cell (which then moves out into the duct), the build up of contamination inside the mounting cell will be reduced. It is essential that this air supply is oil and dirt free. Precautions such as a filter and a liquid trap should be installed in the air-line.

4.7.2 Functional Testing

Cross-Duct Excel incorporates a built in gassing cell for functional test purposes. In order to use the gassing cell, the mounting cell lid must be in place, to maintain a gas tight seal.

4. CROSS-DUCT EXCEL

Ensure that before using the gassing cell for the first time, remove the ends of the plastic nozzles (with a knife or wire cutters). Rubber end caps are used to seal the tubes afterwards.

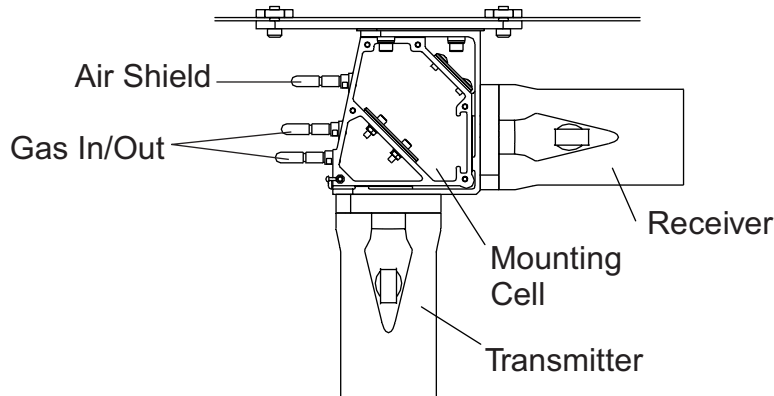

To get the best accuracy when using the gassing cell:

- (1) Ensure that the gassing cell contains fresh air, and perform a zero calibration on the Excel
- (2) Apply the test gas and allow sufficient time to fully fill the gassing cell and check that the Searchline Excel output stabilises.

A flow rate of less than 0.5 litres per minute is advisable, to avoid pressurising the gassing cell.

- (3) For a methane calibrated unit tested with 100%v/v methane, the expected reading can be calculated from:

$$\text{Gas reading} = 100\%LEL / (2 \times \text{duct width})$$

A few examples are shown in the following table, and the tolerance to be applied is $\pm 20\%$ of reading or $\pm 10\%LEL$ (whichever is greater). The variability in the readings are due to a number of factors such as variation in air pressure, flow rate, and tolerances in the gas composition.

Test Gas	Duct Width	Expected Reading	* Expected Reading (FM)
100% v/v Methane	0.5m	100%LEL \pm 20%LEL	100%LEL/m \pm 20%LEL/m
100% v/v Methane	0.8m	60%LEL \pm 12%LEL	60%LEL/m \pm 12%LEL/m
100% v/v Methane	1.0m	50%LEL \pm 10%LEL	50%LEL/m \pm 10%LEL/m
100% v/v Methane	1.5m	33%LEL \pm 10%LEL	33%LEL/m \pm 10%LEL/m
100% v/v Methane	2.0m	25%LEL \pm 10%LEL	25%LEL/m \pm 10%LEL/m

* For a definition of %LEL/m units for the FM version of the Excel Cross-Duct see **Appendix B**.

- (4) After checking the reading, ensure that the gas is flushed out of the gassing cell, with clean air or nitrogen, until the reading returns to zero.
- (5) Finally replace the rubber caps over the gassing ports.

4. CROSS-DUCT EXCEL

4.7.3 Display Gas Reading

To check the gas reading from the Cross-Duct Searchline Excel, follow the procedure described in **Chapter 5**, section 5.2.

4.8 PROBLEM SOLVING

Any problems encountered with the Cross-Duct Excel are likely to be similar to those affecting the Open-Path version. See **Chapter 6** for a problem solving guide.

The beam from the Transmitter is invisible, but during normal operation, the Transmitter can be heard ticking at 4Hz. In addition, when cleaning the optical surfaces include the beamsplitter and the retro-reflector panel.

5. MAINTENANCE

The Searchline Excel Open-Path Gas Detector requires little maintenance other than occasional cleaning. Depending on the local regulations and site conditions, cleaning and functional testing of the gas detector can be carried as described in the following sub-sections. The gas detector should remain powered during these procedures.

Caution: *Searchline Excel does not contain any user serviceable parts. Do not open either the Transmitter or Receiver unit. The warranty of units which have been opened is invalidated.*

NOTE: *THE INFRARED BEAM IS INVISIBLE AND EYE SAFE.*

5.1 INSPECTION AND CLEANING

Caution: *Do not use solvents or abrasives on the Searchline Excel units.*

- (1) Inspect the Searchline Excel units, junction box and cabling for signs of physical damage.
- (2) Using the SHC1 Handheld Interrogator inhibit the Searchline Excel signal output.
*Since the signal output may vary during cleaning, due to the optical path being disturbed, it is important to inhibit the analogue output. The quickest way to inhibit the Excel output is to select **DISPLAY** from the **Calibration** menu.*
- (3) Clean any dust or dirt from the Searchline Excel windows using soapy water or window cleaner and a soft cloth.
- (4) Using the SHC1 Handheld Interrogator release the Searchline Excel signal output.
*The output can be released by pressing **ESC** followed by **↵** on the keyboard.*
- (5) Using the SHC1 Handheld Interrogator re-zero the unit.
*See **Appendix A** for details about how to use the Interrogator.*

5.2 FUNCTIONAL CHECKING

- (1) Connect the SHC1 Handheld Interrogator to the Receiver.
- (2) Select **DISPLAY** from the **Calibration** menu.
- (3) Insert the appropriate Test Filter into the beam.
- (4) Check the display reads as follows for the selected filter.

Receiver Calibrated For:	Response to 1 LEL.m Filter	Response to 3 LEL.m Filter
Methane	1.0 - 1.7 LEL.m	2.0 - 4.3 LEL.m
Ethane	0.6 - 1.1 LEL.m	2.0 - 2.6 LEL.m
Propane	0.7 - 1.2 LEL.m	2.2 - 2.8 LEL.m
Butane	0.9 - 1.5 LEL.m	2.7 - 3.4 LEL.m
Pentane	1.0 - 1.7 LEL.m	2.9 - 3.6 LEL.m
Hexane	1.1 - 1.8 LEL.m	3.4 - 4.3 LEL.m

- (5) If the display reading does not fall within the expected limits, refer to **Chapter 6**.

5. MAINTENANCE

5.3 CALIBRATION CHECK USING THE GASSING CELL

The gassing cell is designed to allow easy calibration checking using a high concentration test gas as opposed to the standard plastic test filters. The integrated LEL.m reading of the gas concentration in the cell can be calculated using the following formula:

$$\text{Int(LeI.m)}_{xl} = L_{\text{cell}} * (\text{Conc}_{\text{gas}} / \text{LEL}_{\text{gas}})$$

where:

Int(LeI.m)_{xl} = Integrated LEL.m reading output by Searchline Excel in LEL.m.

L_{cell} = Length of cell in metres.

Conc_{gas} = Gas concentration in %v/v.

LEL_{gas} = Lower Explosion Limit of the gas in %v/v.

The test gas must be the same as the test gas used during the factory calibration of the Searchline Excel unit and ideally the concentration should be between 2 and 5 LEL.m and never below 1 LEL.m.

Note: Where a different test gas is used, the typical value for cross-sensitivity is not sufficiently precise to enable valid calibration checks to be performed using the Gassing Cell, however, response tests can be easily performed with the plastic Test Filters as described in section 5.1.2.

WARNING

Take the necessary precaution to ensure safety when dealing with these high concentration gases.

The gassing cell supplied by Zellweger Analytics (Part No: 2104B2326) is 0.15m long and the following table outlines the response expected when using this gassing cell:

Gas type	LEL of the gas	Concentration applied	Calculated response with 0.15m gas cell.	4-20mA output
Methane	5.0 %v/v	100 %v/v	3 LEL.m	13.6mA
Ethane	3.0 %v/v	50 %v/v	2.5 LEL.m	12mA
Propane	2.0 %v/v	50 %v/v	3.75 LEL.m	16mA
Butane	1.5 %v/v	50 %v/v	5 LEL.m	20mA

For the Ethylene version of Excel, the following gas concentrations are suggested

Gas type	LEL	Concentration applied	Calculated Response	4-20mA output
Ethylene	2.7%	54%	3 LELm	13.6mA
Propylene	2.0%	50%	3.75 LELm	16mA
Butadiene	2.1%	42%	3 LELm	13.6mA

5. MAINTENANCE

WARNING

These gases are flammable and/or toxic.
Take appropriate precautions when handling.

To get the best accuracy when using the gassing cell:

- (1) Connect the gassing cell to the Searchline Excel.
- (2) Zero Searchline Excel with the empty gassing cell.
- (3) Apply the test gas to the gassing cell and allow sufficient time to fully flush the cell without pressurising it and check that the Searchline Excel output stabilises.
- (4) Check the Searchline Excel output is as indicated in the above table $\pm 5\%$ fsd.
- (5) Remove the gassing cell.
- (6) Re-zero Searchline Excel.

Note: Pentane, Hexane, Ethanol and Methanol cannot be used with the gassing cell. At normal temperatures, these substances do not vapourise sufficiently to give a useful signal in the short path of the gassing cell.

5.4 DISPLAY GAS READING

This procedure displays details about the current gas/gas table. Carry out the following procedure:

- (1) Connect the SHC1 Handheld Interrogator to the gas detector.
See **Connecting the Interrogator to the Searchline Excel Gas Detector** in section 3.7.6.
- (2) Switch on the SHC1 Handheld Interrogator.
See **Powering Up** in section 3.7.6.
- (3) Select **DISPLAY** from the **Main** menu by pressing the ▲ (up) and ▼ (down) keys on the keypad to navigate through the menu options.
- (4) Press ↵ on the Interrogator keypad to display the **Display** menu.
- (5) Select **GAS READING** from the **Display** menu.
- (6) Press ↵ on the keypad.

A display similar to the following is now displayed.

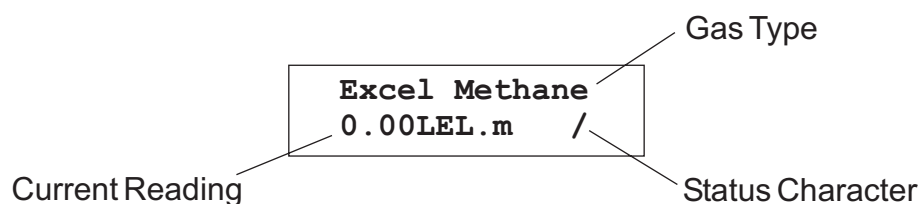

The first line of the display shows the name of the gas or its identifier in a special gas table.

5. MAINTENANCE

The second line shows the gas reading and measurement units along with a gas detector status indicator.

The status character at the end of the second line indicates one of the following:

/ - Normal Operation

A spinning line shows the unit is in the fully active state.

| - Inactive State

A stationary line shows the unit is in the inactive state.

w - Active Warning

F - Active Fault

B - Beam Blocked

- (7) Switch off the Interrogator (see section **3.7.7 Finishing Up**) and disconnect it from the gas detector.

5.5 ALIGNMENT TELESCOPE

To clean the telescope lens/mirror:

- (1) Moisten the surface of the lens/mirror by breathing on it.
- (2) Using a soft tissue or lens cloth, lightly wipe the lens/mirror dry with a minimum number of strokes.

The wiping material may be slightly dampened with a lens cleaning fluid as sold in any camera store.

5.6 OPERATIONAL MAINTENANCE (FM)

As required as a criterion for the FM Performance Approval, routine operational verification is recommended once within a three month period and is required once within a six month period using one of the following methods.

WARNING

The following procedure will indicate a gas reading. Ensure all required personal have been notified prior to starting and completing the procedure.

- Following the procedure described in section **5.1.2** insert a known test filter in the beam path. Record the response to the test filter and verify that the response is within the tolerance for stability and repeatability.
- Following the procedure described in section **5.1.3**, test the unit's response to high %V/V gas in a gassing cell. Verify that the response is within the tolerance for stability and repeatability.
- For Cross-Duct units, follow the procedure described in section **4.7.2** and verify that the response to high %V/V gas introduced into the gassing cell is within the tolerance for stability and repeatability.

6. PROBLEM SOLVING

The majority of gas detector problems/faults can be diagnosed and corrected using the installation and alignment kit.

The alignment kit includes:

- **SHC1 Handheld Interrogator**
- **alignment telescope**
- **set of functional test filters**

An electrical multimeter is also useful when diagnosing electrical/wiring problems.

Refer to the troubleshooting tables in this chapter for a list of problems, possible causes and actions.

Caution: *Searchline Excel does not contain any user serviceable parts. Do not open either the Transmitter or Receiver unit. The warranty of units which have been opened is invalidated.*

NOTE: *THE INFRARED BEAM IS INVISIBLE AND EYE SAFE.*

RS485 Modbus signal errors may occur when Excel is connected via a DX100 (M) Termination Unit and is interrogated/commanded from a network control centre. For troubleshooting these issues refer to the **DX100 Series Termination Units Technical Handbook**.

If, after following the recommendations in this section, the problem persists, please make available the following information before contacting Zellweger Analytics:

- **Installation Check Sheet**
See **Chapter 3**.
- **Any error message**
Displayed on the Handheld Interrogator screen.
- **Any error code**
Displayed on the Handheld Interrogator screen.

Fault/Problem	Causes	Remedies
Output is 0mA	Unit is in <i>FAULT</i> condition	Connect the SHC1 Interrogator to the unit and use its DIAGNOSTIC menu options to ascertain the reason for the FAULT report.
	Beam block	Check that beam path is clear from the Transmitter to the Receiver. Remove any obstruction if present.
	Transmitter or Receiver misaligned	<ol style="list-style-type: none"> 1) Connect the SHC1 Handheld Interrogator to the unit and check the signal levels. 2) If signal levels are low, use the telescope and Interrogator to optimise Receiver alignment. 3) If signal levels remain low after re-aligning Receiver, check the Transmitter alignment using telescope. 4) Re-zero the unit after alignment. See Appendix A.5.3.4.

6. PROBLEM SOLVING

Fault/Problem	Causes	Remedies
	Electrical installation problem	<ol style="list-style-type: none"> 1) Check that the +24V supply is reaching the unit. Voltage at the unit should be between +18V and +32V. 2) Check cables and connections to the unit, especially the 4-20mA loop connections. 3) Check that the unit has the correct type of 4-20mA output for use with the controller that it is connected to.
	Heavy contamination of optics	Check the Transmitter and Receiver windows for build up of contamination. Clean the windows if required. Re-zero unit.
	Very low visibility along beam path due to dense fog, blizzard or sand-storm conditions	<ol style="list-style-type: none"> 1) Check that the Transmitter can be seen from the Receiver. If Transmitter can be seen, even with some difficulty, low visibility is unlikely to be the problem. 2) If the Transmitter cannot be seen from the Receiver, very low visibility could be the problem. Wait until visibility improves and verify that the unit then returns to operational status.
Output is 2.5mA. (BEAM BLOCK)	Beam path is blocked	Check that the beam path is clear from the Transmitter to Receiver. Remove any obstruction if present.
	Transmitter or Receiver misaligned	<ol style="list-style-type: none"> 1) Connect SHC1 Interrogator to unit and check signal levels. 2) If signal levels are low, use the telescope and SHC1 Interrogator to optimise Receiver alignment. 3) If signal levels remain low after re-aligning Receiver, check the Transmitter alignment using the telescope. 4) Re-zero the unit after alignment. See Appendix A.5.3.4.
Output is 3mA (LOW SIGNAL)	Heavy contamination of optics	Check the Transmitter and Receiver windows for build up of contamination. Clean windows if required. Re-zero the unit.
	Transmitter or Receiver misaligned	<ol style="list-style-type: none"> 1) Use the telescope and Interrogator to optimise Receiver alignment. 2) If signal levels remain low after re-aligning Receiver, check the Transmitter alignment using the telescope. 3) Re-zero the unit after alignment. See Appendix A.5.3.4.
Output is 2mA (INHIBIT)	Unit has been inhibited by the Interrogator	Release output from INHIBIT state using SHC1 Interrogator.
	Unit executing power-up routine	<ol style="list-style-type: none"> 1) Wait for 1 minute. When power-up routine is completed satisfactorily the unit's output should exit the INHIBIT state. 2) If unit remains in INHIBIT, check the +24V supply is reaching the unit. If the voltage is below +18V or is fluctuating above and below +18V, the unit may be being prevented from completing power-up. (This is an electrical installation problem.)

6. PROBLEM SOLVING

Fault/Problem	Causes	Remedies
Comms Error reported by Interrogator software	Wrong communication mode selected on the Interrogator	1) Select Change Mode option on the Interrogator. 2) Change the communication mode to Excel .
	Interrogator software version is incompatible with Excel software version	Version 1V00 Interrogator software to be used with Excels running 1V0 software. Version 2V0 Interrogator software can be used with Excels running 2V0 software or higher. Version 3V0 and 3V1 Interrogator software can be used with Excels running 3V0 software or higher. The latest versions of Interrogator software is 4V0 . This versions work with 3V0 and higher Excels, Optima and Optima Plus.
	Incorrect communication connection	1) Check that Interrogator is correctly plugged into the IS socket on the DVC100/DX100/DX100 (M) junction box. 2) Check that the RS485 A and B wires from the Excel unit have been connected to the correct terminals inside the DVC100/DX100/DX100 (M) junction box.
	Excel unit is not powered up	Check that the +24V supply is reaching Excel unit correctly. The Supply voltage at unit should be between +18V and +32V.
	Interrogator battery low	Check the Interrogator battery and replace if low. See Appendix A. Section A.4.3.
Interrogator Installation Failed message when attempting initialisation	The installation has failed to meet the acceptable criteria of the Instrument Assisted Alignment (IAA) check	1) Check that the signal levels reaching the Receiver are greater than 0.7 and less than 1.5. 2) Check that the correct range has been entered for the installed path length. 3) Check that the alignment of the Receiver has been fully optimised. The received signals must be peaked up to the maximum achievable. Adjusting the alignment until the signals are just above the minimum signal threshold and then leaving it at that is poor practice and will not always result in an installation that passes the IAA check criteria. 4) Check the alignment of the Transmitter. 5) Check that there are no objects obscuring part or all of the beam path. 6) Check that the windows of both the Receiver and the Transmitter are clean. 7) Check that the structures that the Transmitter and Receiver are mounted on are stable and free from significant angular movement/vibration. 8) Check that there is no gas in the beam - which prevents successful zeroing. 9) Installation will fail in conditions of low visibility or fluctuating atmospheric transmission - which degrade signal quality. Do not attempt installation during conditions of heavy rain, snow or fog.

6. PROBLEM SOLVING

Fault/Problem	Causes	Remedies								
No signal or very low signal at Receiver	Receiver misaligned	Re-align the Receiver, first using the telescope and then using the Interrogator.								
	Transmitter misaligned	Re-align the Transmitter using the telescope.								
	The beam path has become obscured	Check that the beam path is clear from Transmitter to Receiver. Remove any obstruction if present.								
No output from Transmitter		<ol style="list-style-type: none"> 1) Check that the Transmitter is flashing. When viewed on the axis, an orange flash can be seen coming from the Transmitter. Alternatively, listen for a distinct ticking sound when the lamp flashes. <i>Note: The infrared beam is invisible and eye safe.</i> 2) If the Transmitter is not flashing, check that the +24V supply is reaching the Transmitter correctly. 								
Unit does not respond exactly as expected to test filters	Plastic test filters are only an approximate simulation of gas	Searchline Excel units are calibrated on real gas. This results in a variation of the response of different Excel units to plastic test filters. See section 5.1.2. <ol style="list-style-type: none"> 1) Check that the response to the test filters is within the limits stated in this handbook. See section 5.1.2. 2) Check that the value being used for response testing corresponds correctly to the target gas that the unit has been calibrated for. 								
	Receiver misaligned	<ol style="list-style-type: none"> 1) Use the telescope and Interrogator to optimise Receiver alignment. 2) Re-zero unit. 								
	Contamination of windows	<ol style="list-style-type: none"> 1) Check the Transmitter and Receiver windows for build up of contamination. Clean windows if required. See Chapter 5. 2) Re-zero unit. 								
	Drift of unit's zero position	<ol style="list-style-type: none"> 1) Verify that there is no gas in the beam path. 2) Re-zero the unit. 								
Unit appears to be reporting a negative gas reading on the 4-20mA	Misinterpretation of INHIBIT , BEAM-BLOCK or LOW SIGNAL currents that are output on the 4-20mA	<p>Searchline Excel does not report negative gas readings on the 4-20mA.</p> <ol style="list-style-type: none"> 1) Configure controller/PLC to interpret and present currents below 4mA correctly, or, 2) Familiarise operators with the interpretation of sub-4mA output currents from Excel as follows: <table style="margin-left: 40px;"> <tr> <td>FAULT</td> <td>0mA</td> </tr> <tr> <td>INHIBIT</td> <td>2mA</td> </tr> <tr> <td>BEAM-BLOCK</td> <td>2.5mA*</td> </tr> <tr> <td>LOW SIGNAL</td> <td>3mA*</td> </tr> </table> or, 3) Reconfigure the INHIBIT, BEAM-BLOCK and LOW SIGNAL currents output by the Excel unit. 	FAULT	0mA	INHIBIT	2mA	BEAM-BLOCK	2.5mA*	LOW SIGNAL	3mA*
FAULT	0mA									
INHIBIT	2mA									
BEAM-BLOCK	2.5mA*									
LOW SIGNAL	3mA*									

6. PROBLEM SOLVING

Fault/Problem	Causes	Remedies
Diagnostics report <i>Neg Gas Reading</i>	Receiver misaligned	1) Re-align the Receiver, first using the telescope and then using the Interrogator. 2) Re-zero the unit.
	Contamination of windows	1) Check the Transmitter and Receiver windows for build up of contamination. Clean windows if required. See Chapter 5 . 2) Re-zero the unit.
	Negative drift of unit's zero position	Re-zero the unit.
Diagnostics report <i>Baseline Drift</i>	Receiver misaligned	1) Re-align the Receiver, first using the telescope and then using the Interrogator. 2) Re-zero the unit.
	Contamination of windows	1) Check the Transmitter and Receiver windows for build up of contamination. Clean windows if required. 2) Re-zero the unit.
	Drift of unit's baseline	Re-zero the unit
Diagnostics report <i>Bad Temperature</i>	Unit has been operated at a temperature outside its specified and certified range	1) When Ex certified equipment is operated outside its certified range, its type approval certification is invalidated along with its warranty. Such equipment should be removed from service in potentially explosive atmospheres. 2) Investigate the cause of the excessive temperature excursion and take steps to prevent recurrence. (e.g. fit sunshade or heat-shield, or relocate detector, etc.)
Diagnostics report <i>Supply Fault</i>	Incorrect supply voltage reaching unit	1) Check that the +24V supply voltage reaching the unit (it should be between +18V and +32V). 2) Identify the cause of incorrect supply voltage reaching the unit and rectify.
Diagnostics report <i>DSP Fault</i>	Fault on the unit's digital PCB	If this fault is displayed when the unit is interrogated, it cannot be remedied in the field.
Diagnostics report <i>NV-RAM Fault</i>	A fault has been detected in the NV-RAM	If this fault is displayed when the unit is interrogated, it cannot be remedied in the field.
Diagnostics report <i>RTC Fault</i>	The time and date record being stored by the Real Time Clock (RTC) has been lost	1) Re-enter the time and date using the Interrogator. 2) Cycle the power applied to the unit. 3) Verify that the time and date record was maintained after cycling the power.
Diagnostics report <i>Volt Ref Fault</i>	Voltage reference fault detected	If this fault is displayed when the unit is interrogated, it cannot be remedied in the field.

7. SPECIFICATIONS

7.1 SYSTEM

	OPEN-PATH			CROSS-DUCT
	SHORT RANGE	MEDIUM RANGE	LONG RANGE	
Available Gases	All: Methane, Ethane, Propane, Butane, Pentane, Hexane, Ethylene, Propylene, Butadiene, Methanol, Ethanol.			
Range	0 - 5 LELm	0 - 5 LELm	0 - 5 LELm	0 - 100%LEL (%LEL/m)
Recommended Alarm Setting	Low 1 LELm High 3 LELm	Low 1 LELm High 3 LELm	Low 1 LELm High 3 LELm	Low 20%LEL (%LEL/m) High 50%LEL (%LEL/m)
Minimum Alarm Setting	0.5LELm	0.5LELm	0.5LELm	10%LEL (%LEL/m) (greater than 2.5m)
Path Length	5 - 40m (15 - 130ft)	40 - 120m (130 - 390ft)	120 - 200m (390 - 650ft)	Short 0.5 - 2.5m Long 2.5 - 5.0m
Speed of Response	T90 less than 3seconds	T90 less than 3seconds	T90 less than 3seconds	T90 less than 1 second
Output signal	4 — 20mA Normal operation (0 — 5LELm)	4 — 20mA Normal operation (0 — 5LELm)	4 — 20mA Normal operation (0 — 5LELm)	4 — 20mA Normal operation (0 —100%LEL) (0 —100%LEL/m)
Operating Temp.	All: -40°C to +65°C (-40°F to +150°F)			
Humidity	All: 0 — 99%RH Non-condensing			
Pressure	All: 91.5kPa — 105.5kPa (915 — 1055mBar, non-compensated)			
Repeatability	±0.4LELm	±0.4LELm	±0.4LELm	±10%LEL (%LEL/m) (<1metre width) 2.5%LEL (%LEL/m) (1 - 5metre path)
Temperature Drift (-40°C to+65°C)	±0.2LEL.m @ zero ±0.5LEL.m @3LEL.m	±0.2LEL.m @ zero ±0.5LEL.m @3LEL.m	±0.2LEL.m @ zero ±0.5LEL.m @3LEL.m	±10%LEL (%LEL/m) @ zero ±15%LEL (%LEL/m) @60%LEL
Warm-up Time	All: less than 5 minutes (operational), Less than 1 hour (fully stabilised)			
Power Supply	All: 18 to 32V			
Power Consumption	* Turbo heating activated (below 0°C)			No turbo heating
Transmitter Receiver	3.5/5* W max 8W maximum	5.5/7.5* W max. 8W maximum	5.5/7.5* W max. 8W maximum	Tx/Rx total: 13W maximum
Enclosure Material	All: 316 Stainless Steel			
Weight Transmitter Receiver	3.5kg 3.5kg	7.0kg 3.5kg	7.0kg 3.5kg	Tx/Rx 13kg Reflector panel 1.0kg (short range) 2.5kg (long range)
Vibration	All: 2 — 60Hz, maximum peak to peak amplitude 1mm.			
Divergence/ Misalignment Tolerance	±0.5° (~±35cm at 40m)	±0.5° (~±105cm at 120m)	±0.5° (~±175cm at 200m)	Tx/Rx ±1.5° Retro-tile ±15° (at 5m)
IP rating	All: IP66/67			

7. SPECIFICATIONS

7.2 DETECTABLE GASES

The Searchline Excel Open-Path gas detector (short, medium or long range) will detect the following hydrocarbon gases, individually or in a mixture, in the range 0 — 5LEL.m:

Methane	CH_4
Ethane	C_2H_6
Propane	C_3H_8
Butane	C_4H_{10}
Pentane	C_5H_{12}
Hexane	C_6H_{14}

The Ethylene version of Excel is used to detect the following gases and vapours (it will also respond to the hydrocarbons above, but is only calibrated for the following):

Ethylene	C_2H_4
Propylene	C_3H_6
Butadiene	C_4H_6
Methanol	CH_3OH
Ethanol	$\text{C}_2\text{H}_5\text{OH}$

Note: The Excel Ethylene version has not been evaluated as part of the performance testing relating to the FM approval and therefore is not considered part of the performance approval.

The Cross Duct Excel will detect all of the above gases.

Searchline Excel Gas Response

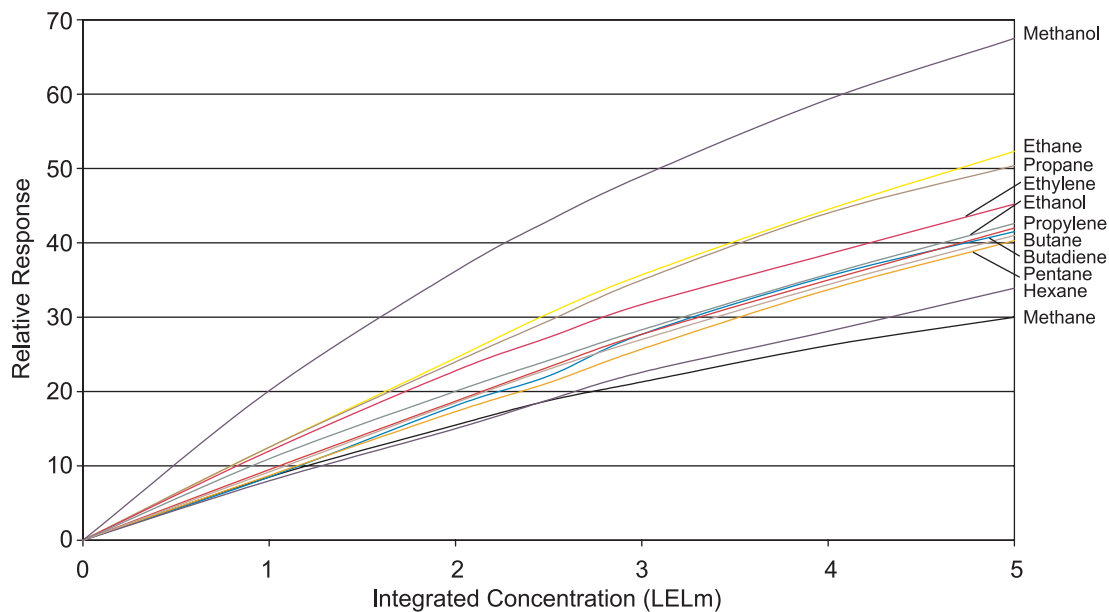

8. CERTIFICATION

8.1 GENERAL

The Searchline Excel system is certified to EEx d and has the following major CENELEC and UL and CSA approvals for worldwide acceptance:

CENELEC

⊕ II 2G, EEx d IIC T5 (T_{amb} -40 to +65°C)

⊕ II 2G, EEx d IIC T6 (T_{amb} -40 to +40°C)

Certificate Numbers:

Open-Path Short Range Transmitter, and Short/Long/Mid Range Receivers,
Cross-Duct Transmitter and Receiver BAS98ATEX

2165X

Open-Path Long Range/Mid Range Transmitters: BAS98ATEX 2299X

UL

Class 1 Groups B, C, D

Class 1 Zone 1 AEx d IIB + Hydrogen (Amb -40°C to +65°C)

File No. E91044

CSA

Class 1 Div 1 groups B, C, D, T5 and
Exd IIC T5 (Amb -40 to +65°C)

File No. LR 48148-38

FM

Class I Div 1 groups B, C, D & T5
(T_{amb} -40 to +65°C)

The Searchline Excel system has been designed, built and tested to meet the latest European standards for Radio Frequency Immunity (RFI).

It has been tested and approved to the following British Standards Institute (BSI) regulations:

BS EN 50081-1 1992

BS EN 50082-2 1995

8. CERTIFICATION

8.2 CENELEC

8.2.1 Transmitter Details

Open-Path

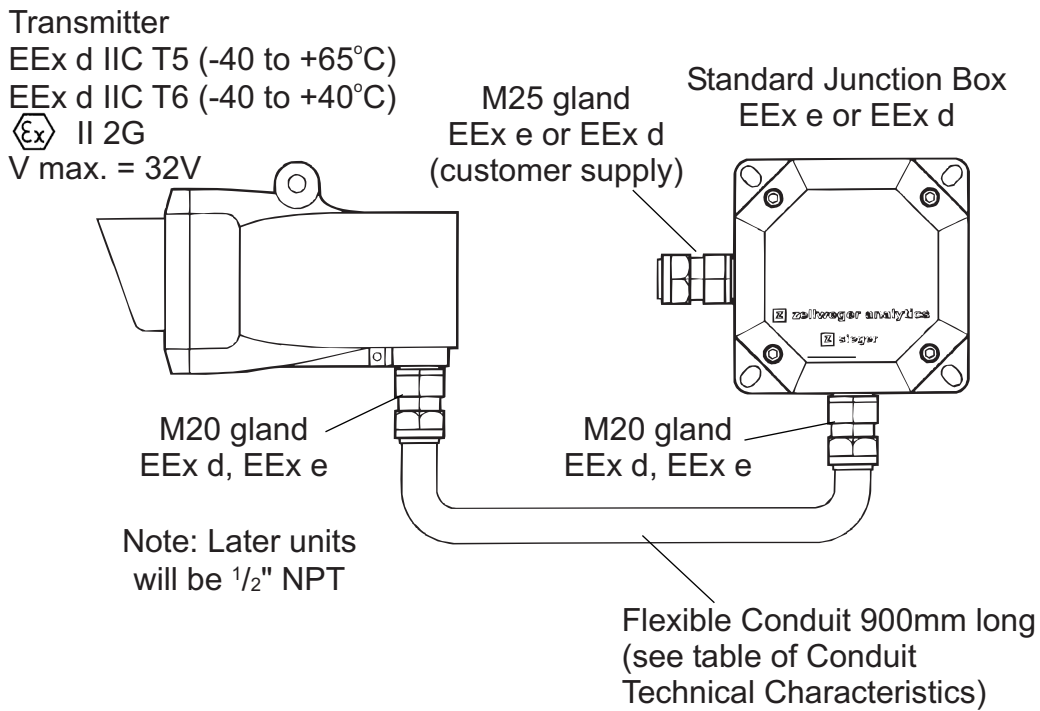

Cross-Duct

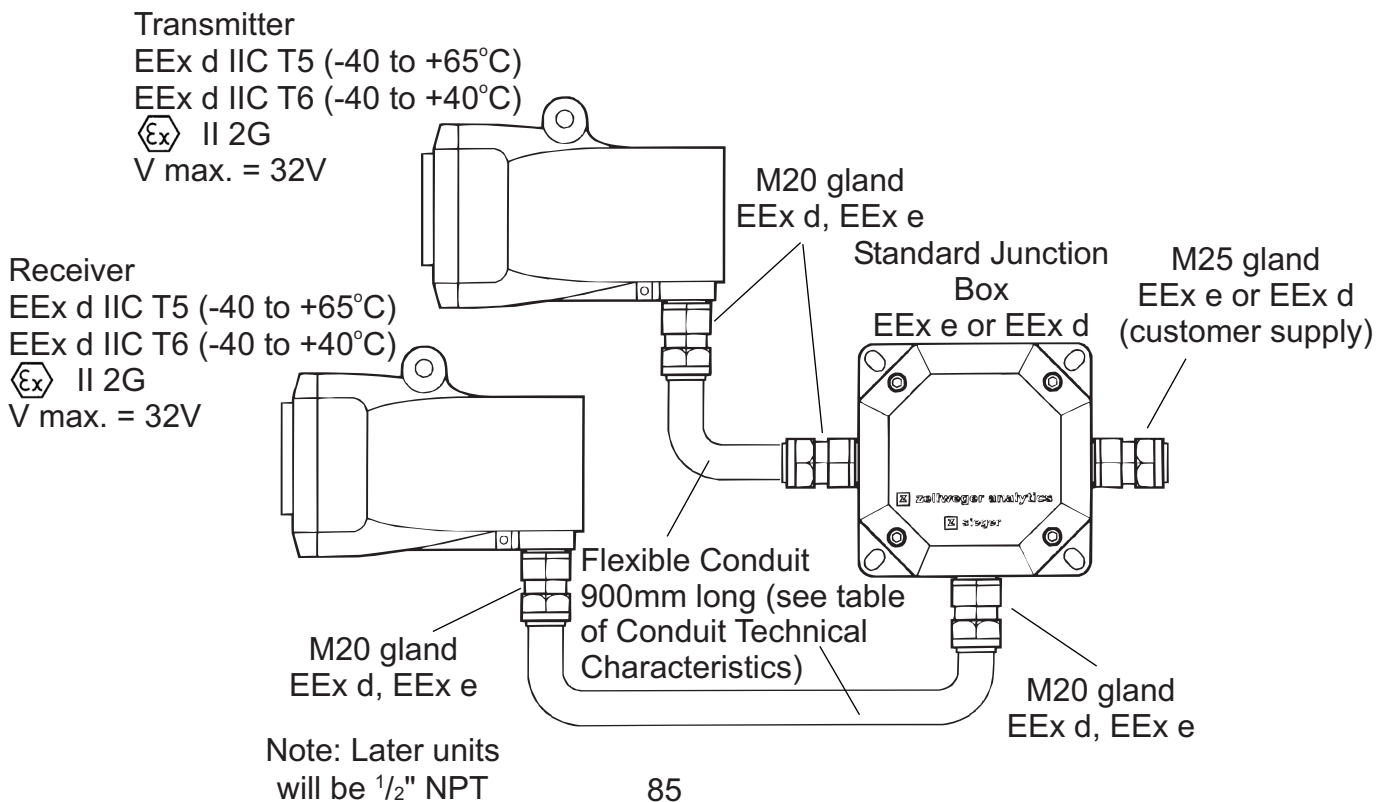

8. CERTIFICATION

8.2.2 Receiver Details

Open-Path

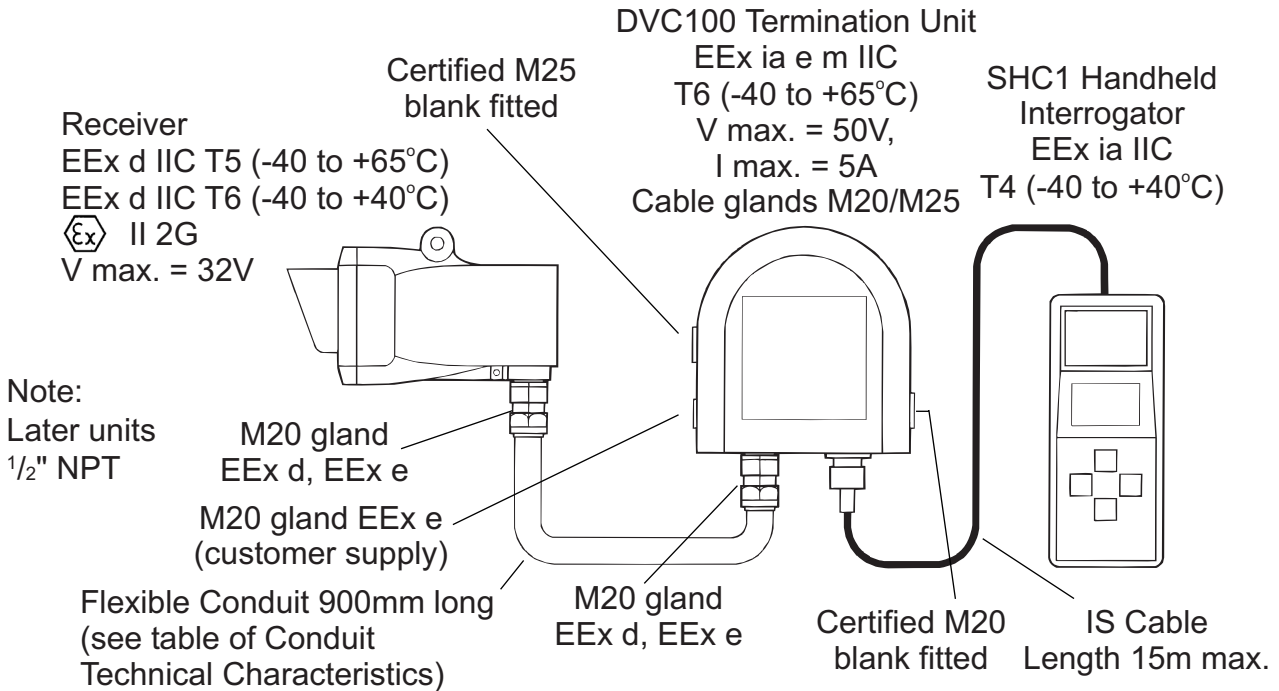

Cross-Duct

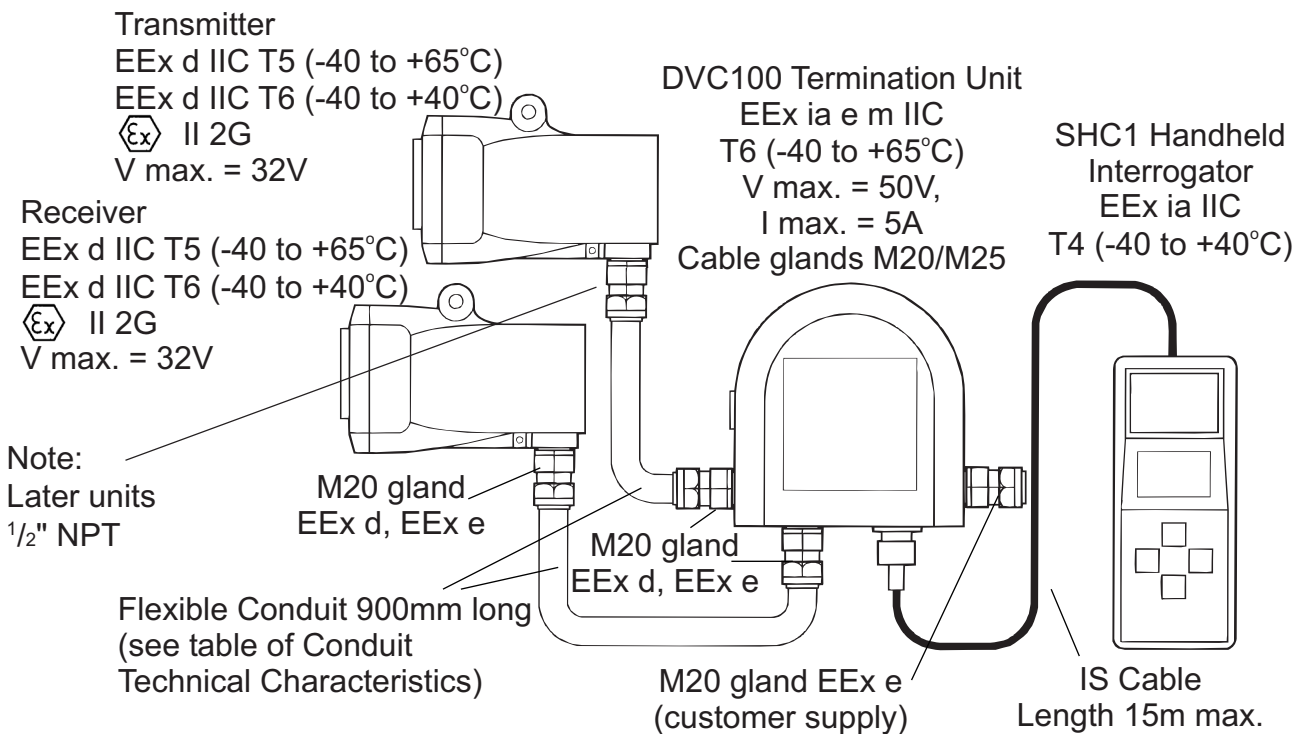

8. CERTIFICATION

8.2.3 Conduit Technical Characteristics

Ingress Protection	IP66 and 67.
Temperature Rating	-40 to +105°C.
Construction	A helically wound galvanised steel core with cotton packing and enhanced oil resistant PVC covering. Covering material displays good resistance to dilute acids, alkalis and hydrocarbon products.
Colour	Grey
Electrical Flash Voltage	More than 24kV.
Insulation Resistance	More than 100M ohms.
Connector Pull off Classification	FRG04: Heavy.
Conductor Crush Classification	FRG04: Heavy.
Flame Propagation	Flame dies in less than 30 seconds after ignition source is removed.
Approvals	Bureau Veritas.

8.2.4 Certification Labels

8.2.4.1 Transmitters

Open-Path Short Range

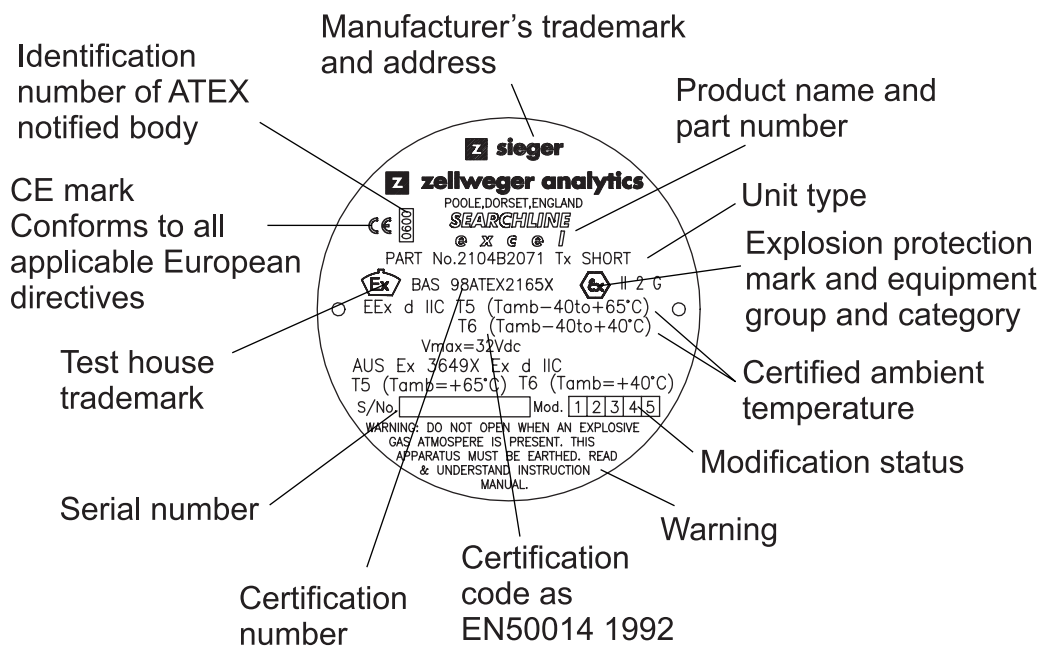

8. CERTIFICATION

Open-Path Long/Mid Range

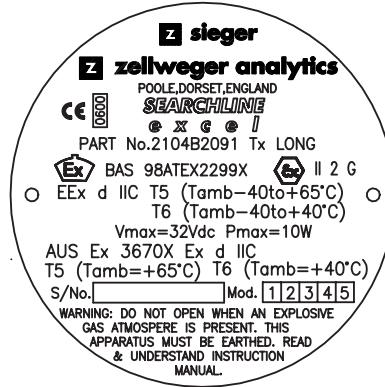

See Open-Path Transmitter Short Range for label explanation.

Cross-Duct

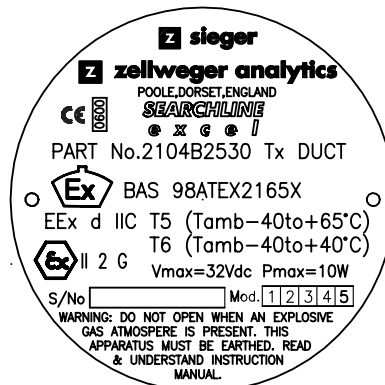

See Open-Path Transmitter Short Range for label explanation.

8.2.4.2 Receivers

Open-Path

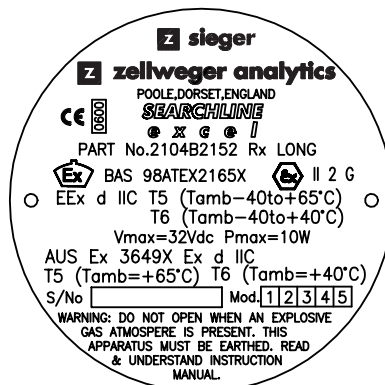

See Open-Path Transmitter Short Range for label details.

8. CERTIFICATION

Cross-Duct

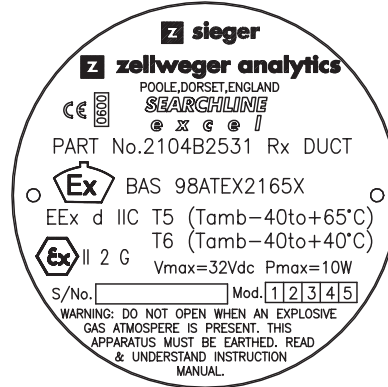

See Open-Path Transmitter Short Range for label explanation

8. CERTIFICATION

8.2.5 System Diagram

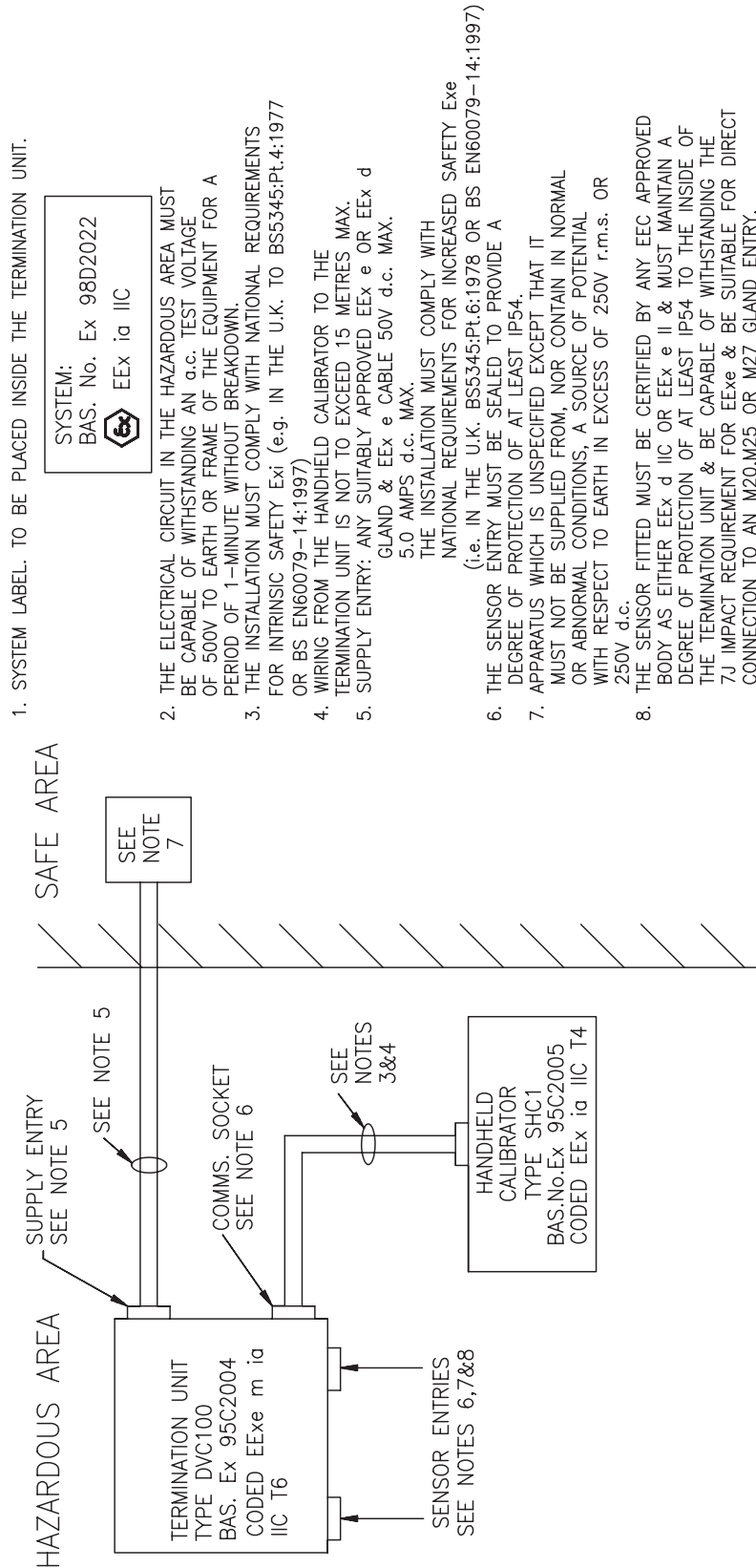

1. SYSTEM LABEL TO BE PLACED INSIDE THE TERMINATION UNIT.

2. THE ELECTRICAL CIRCUIT IN THE HAZARDOUS AREA MUST BE CAPABLE OF WITHSTANDING AN a.c. TEST VOLTAGE OF 500V TO EARTH OR FRAME OF THE EQUIPMENT FOR A PERIOD OF 1-MINUTE WITHOUT BREAKDOWN.

3. THE INSTALLATION MUST COMPLY WITH NATIONAL REQUIREMENTS FOR INTRINSIC SAFETY Exi (e.g. IN THE U.K. TO BS5345:Pt.4:1977 OR BS EN60079-14:1997)

4. WIRING FROM THE HANDHELD CALIBRATOR TO THE TERMINATION UNIT IS NOT TO EXCEED 15 METRES MAX.

5. SUPPLY ENTRY: ANY SUITABLY APPROVED EEx e OR EEx d GLAND & EEx e CABLE 50V d.c. MAX. 5.0 AMPS d.c. MAX.

THE INSTALLATION MUST COMPLY WITH NATIONAL REQUIREMENTS FOR INCREASED SAFETY Exe (i.e. IN THE U.K. BS5345:Pt.6:1978 OR BS EN60079-14:1997)

6. THE SENSOR ENTRY MUST BE SEALED TO PROVIDE A DEGREE OF PROTECTION OF AT LEAST IP54.

7. APPARATUS WHICH IS UNSPECIFIED EXCEPT THAT IT MUST NOT BE SUPPLIED FROM, NOR CONTAIN IN NORMAL OR ABNORMAL CONDITIONS, A SOURCE OF POTENTIAL WITH RESPECT TO EARTH IN EXCESS OF 250V r.m.s. OR 250V d.c.

8. THE SENSOR FITTED MUST BE CERTIFIED BY ANY EEC APPROVED BODY AS EITHER EEx d IIC OR EEx e II & MUST MAINTAIN A DEGREE OF PROTECTION OF AT LEAST IP54 TO THE INSIDE OF THE TERMINATION UNIT & BE CAPABLE OF WITHSTANDING THE 7J IMPACT REQUIREMENT FOR EExe & BE SUITABLE FOR DIRECT CONNECTION TO AN M20,M25 OR M27 GLAND ENTRY.

8. CERTIFICATION

8.3 UL

8.3.1 Transmitters

Open-Path

Transmitter

Class I Div 1 Groups B, C & D and
Class I Zone 1 AEx d IIB +
H2 (Tamb -40 to +65°C)

UL approved explosion
proof junction box

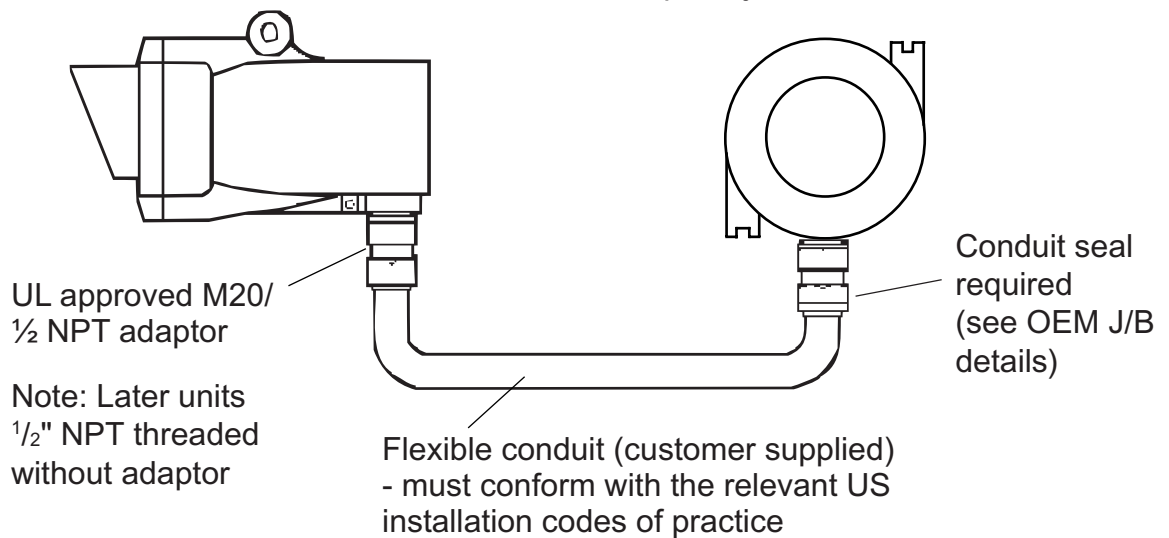

Cross-Duct

Transmitter

Class I Div 1 Groups B, C & D and
Class I Zone 1 AEx d IIB +
H2 (Tamb -40 to +65°C)

UL approved explosion
proof junction box

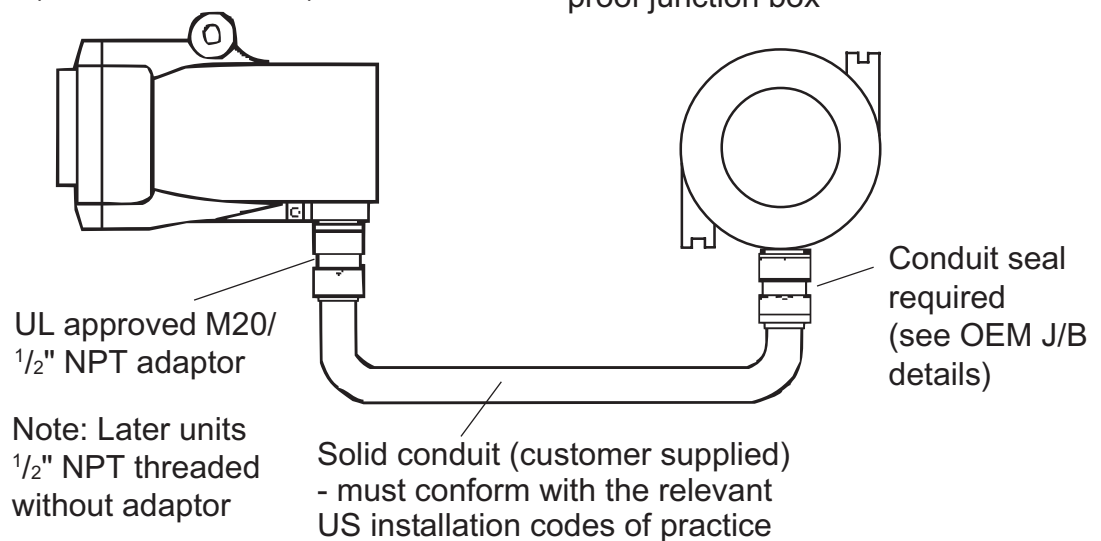

8. CERTIFICATION

8.3.2 Receivers

Open-Path

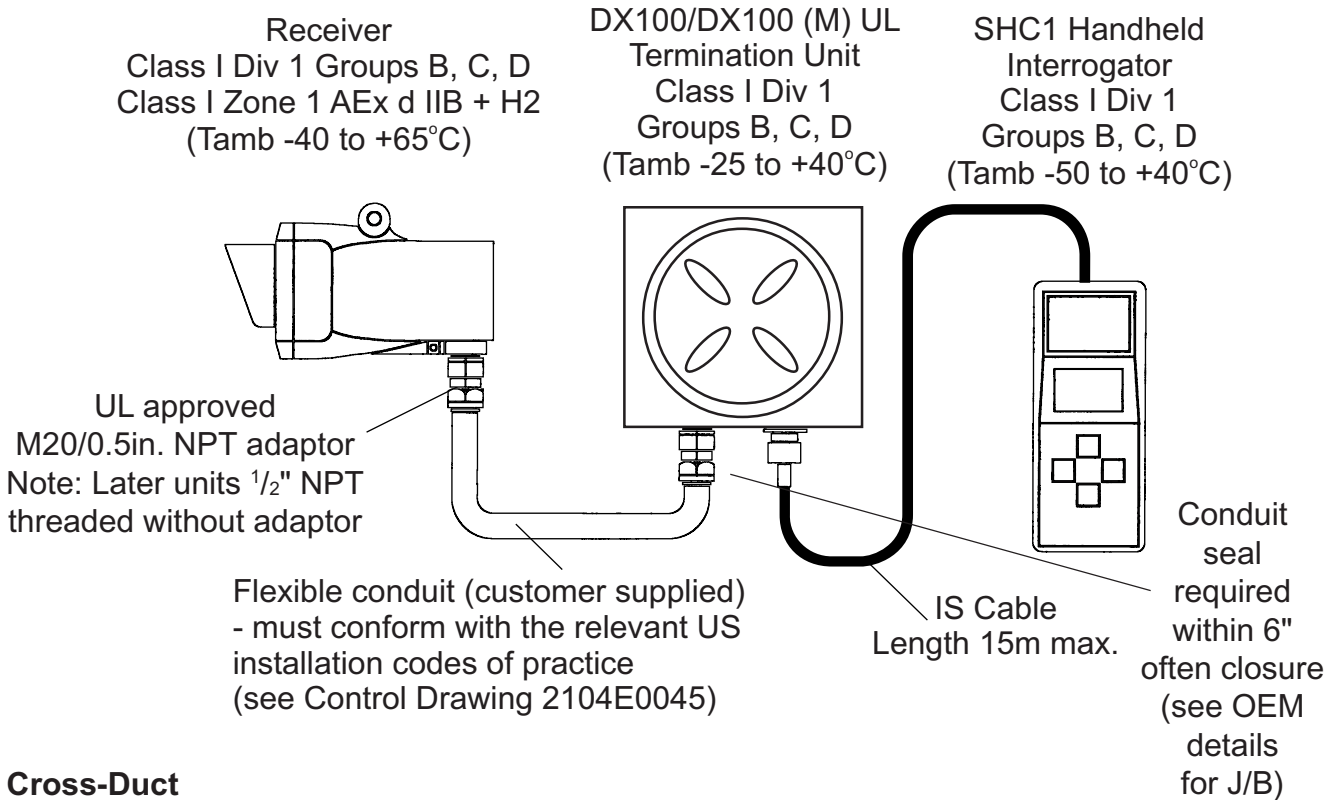

Cross-Duct

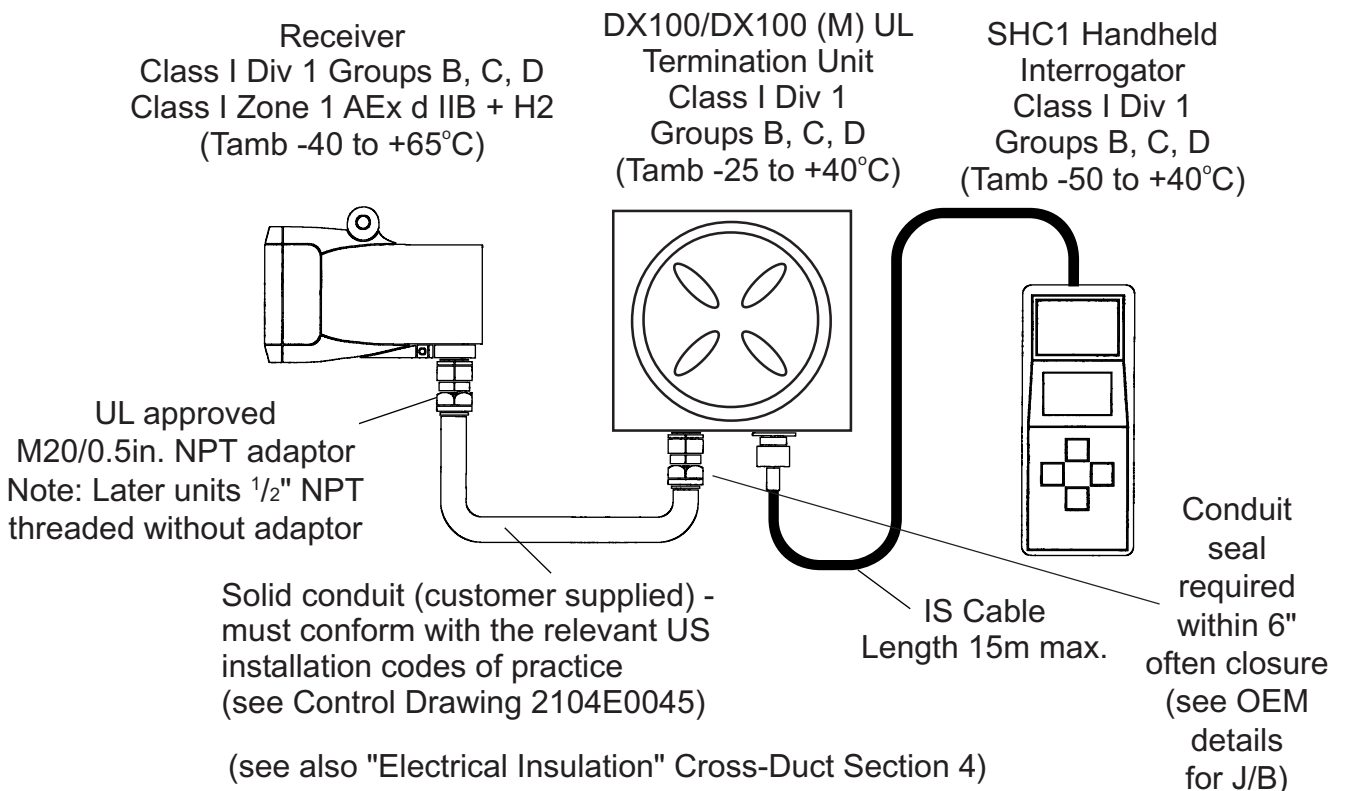

8. CERTIFICATION

8.3.3 Certification Label

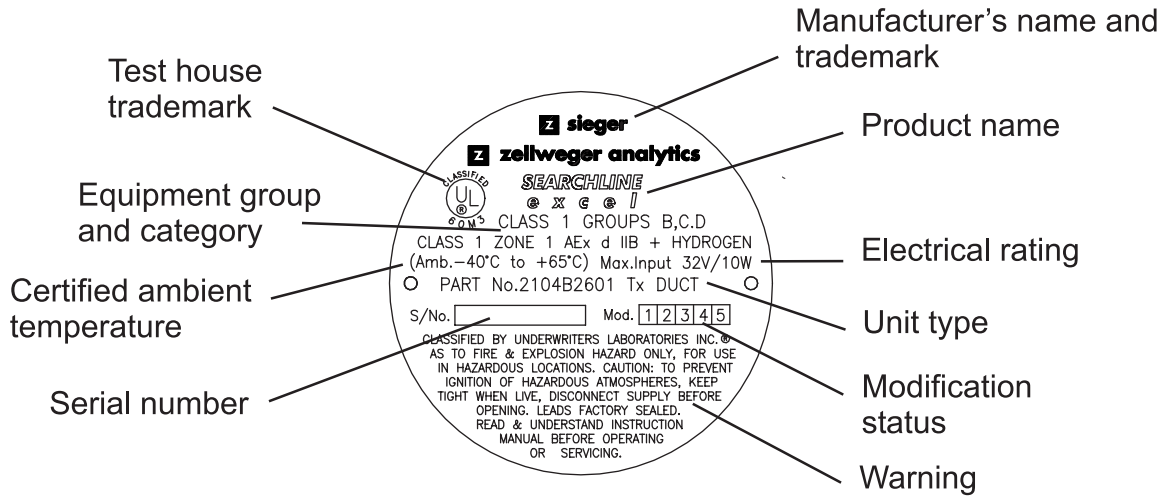

8. CERTIFICATION

8.3.4 System Diagram With DX100 Termination Unit

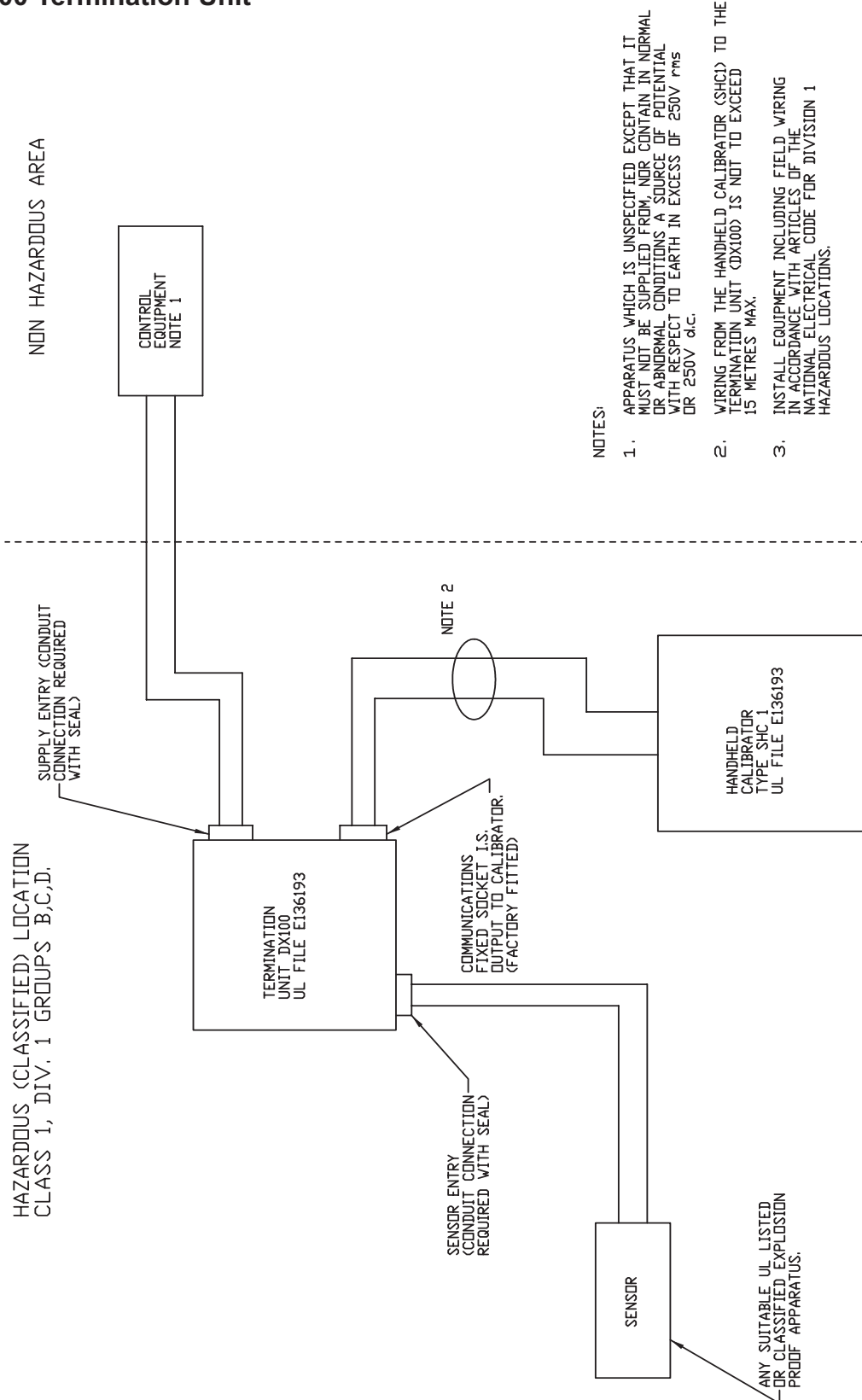

8. CERTIFICATION

With DX100 (M) Termination Unit

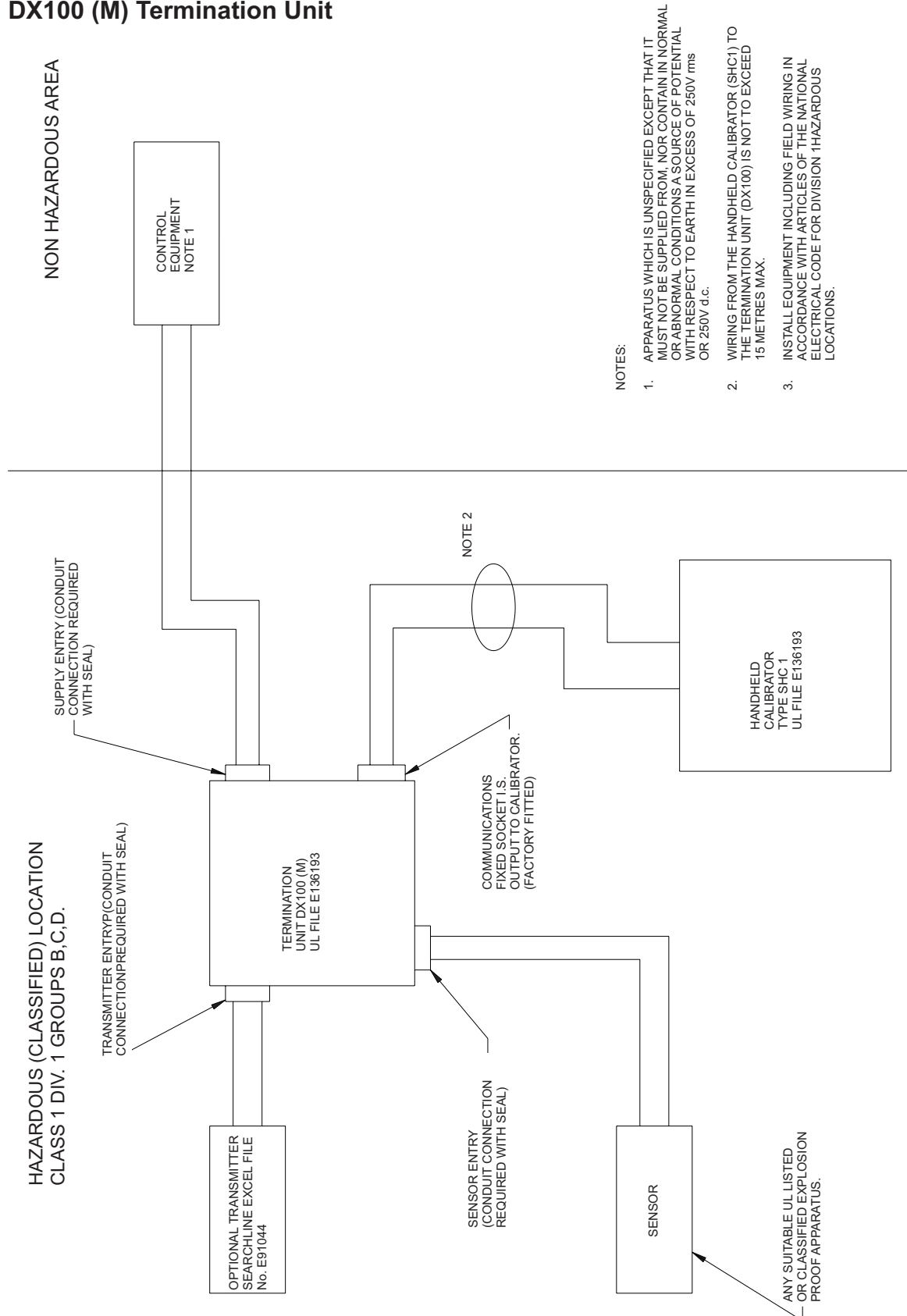

NOTES:

1. APPARATUS WHICH IS UNSPECIFIED EXCEPT THAT IT MUST NOT BE SUPPLIED FROM, NOR CONTAIN IN NORMAL OR ABNORMAL CONDITIONS A SOURCE OF POTENTIAL WITH RESPECT TO EARTH IN EXCESS OF 250V rms OR 250V d.c.
2. WIRING FROM THE HANDHELD CALIBRATOR (SHC1) TO THE TERMINATION UNIT (DX100) IS NOT TO EXCEED 15 METRES MAX.
3. INSTALL EQUIPMENT INCLUDING FIELD WIRING IN ACCORDANCE WITH ARTICLES OF THE NATIONAL ELECTRICAL CODE FOR DIVISION 1 HAZARDOUS LOCATIONS.

8. CERTIFICATION

8.4 CSA/FM

8.4.1 Transmitters

CSA Transmitter:

Class 1 Div 1 Groups B, C & D T5
and Exd 11C T5 (Tamb -40 to +65°C)

FM Transmitter:

Class 1 Div 1, Groups B, C & D (-40 to +65°C)

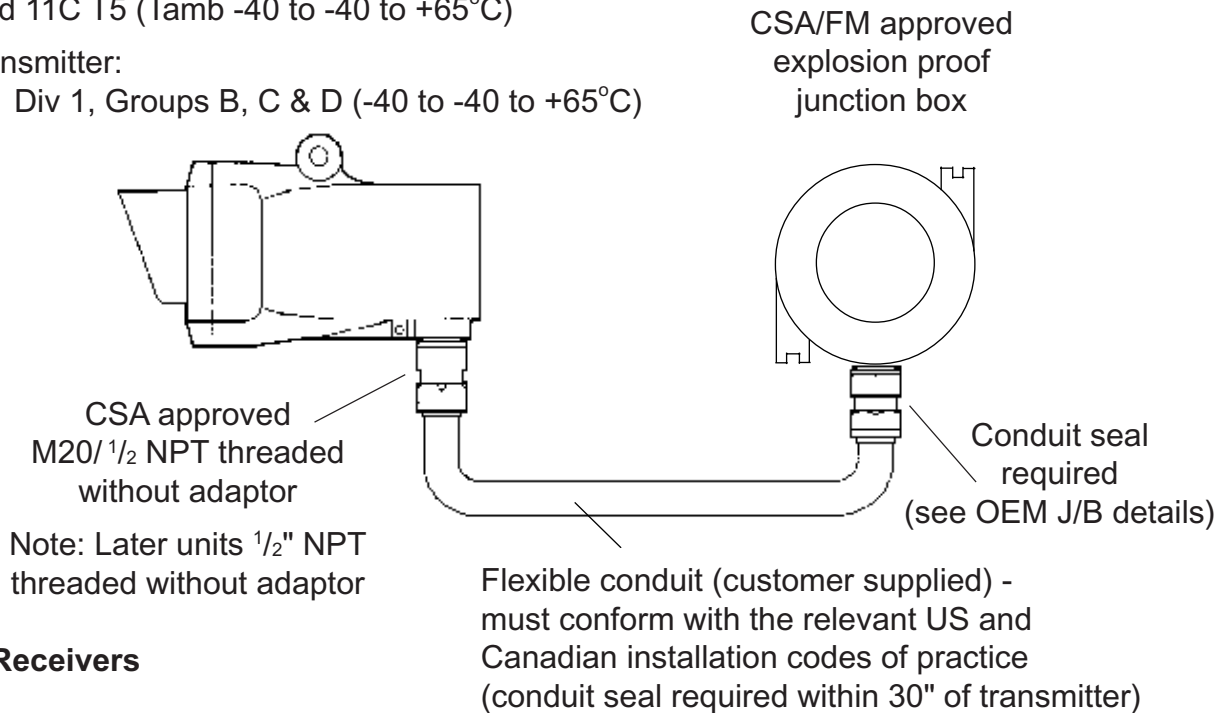

8.4.2 Receivers

CSA Receiver:

Class 1 Div 1 Groups B, C, D, T5 & Exd 11C T5
(Tamb -40 to +65°C)

DX100/DX100(M) CSA/FM Termination Unit Class I Div 1
Groups B, C, D (Tamb -40 to +65°C)

SHC1 Handheld Interrogator CSA/FM
Class 1 Div 1 Groups B, C, D
(Tamb -40 to +65°C)

FM Receiver:
Class 1 Div 1 Groups B, C & D
(-40 to +65°C)

CSA approved M20/0.5in. NPT adaptor

Note: Later units 1/2 inch NPT threaded without adaptor

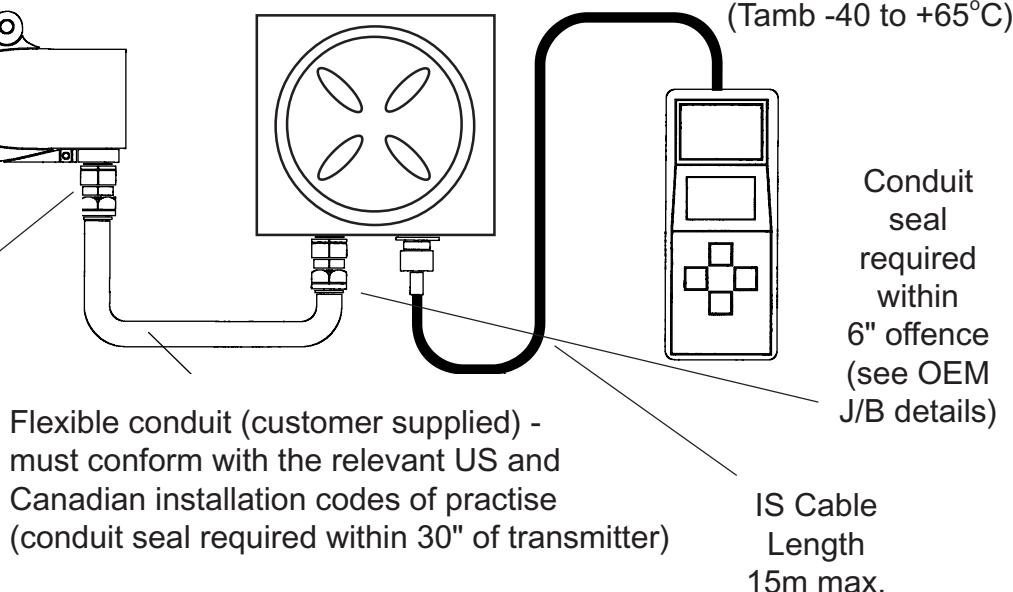

8. CERTIFICATION

CSA Receiver:

Class 1 Div 1 Groups B, C, D
Class 1 Zone 1 AEx d IIB + H2
(Tamb -40 to +65°C)

DX100/DX100(M) CSA/FM
Termination Unit Class I Div 1
Groups B, C, D (Tamb -25 to +40°C)

SHC1 Handheld
Interrogator CSA/FM
Class 1 Div 1
Groups B, C, D
(Tamb -50 to +40°C)

FM Receiver:
Class 1 Div 1
Groups
B, C & D
(-40 to +65°C)

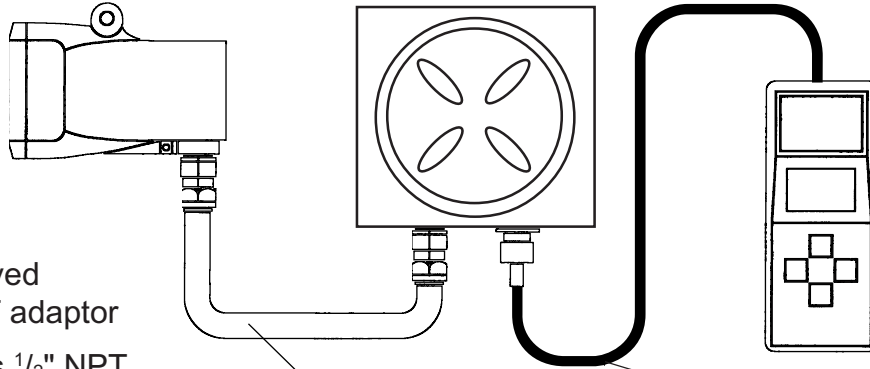

UL approved
M20/0.5in. NPT adaptor

Note: Later units 1/2" NPT
threaded without adaptor

Solid conduit (customer supplied) -
must conform with the relevant US and
Canadian installation codes of practice
(conduit seal required within 30" of transmitter)

Conduit
seal
required
within 6"
of encford
(see OEM
details
for J/B)

IS Cable
Length
15m max.

(see also electrical insulation Cross-Duct Section 4)

8. CERTIFICATION

CSA/FM Certification Label

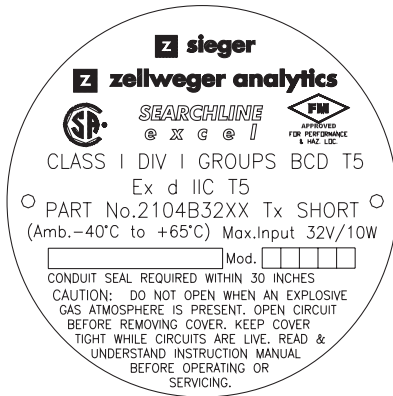

Standard Transmitter

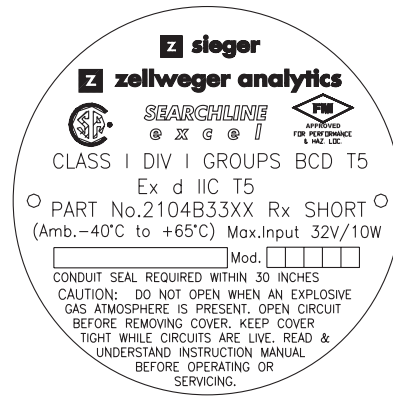

Standard Receiver

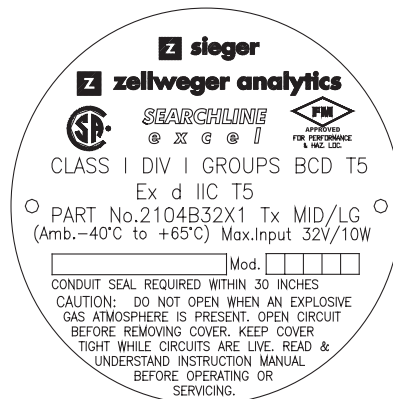

Long-Range Transmitter

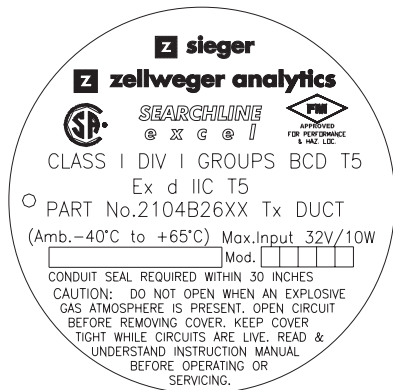

Cross-Duct Transmitter

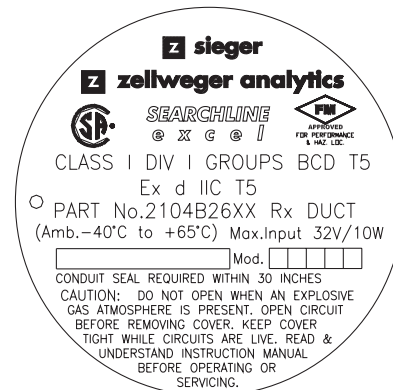

Cross-Duct Receiver

8. CERTIFICATION

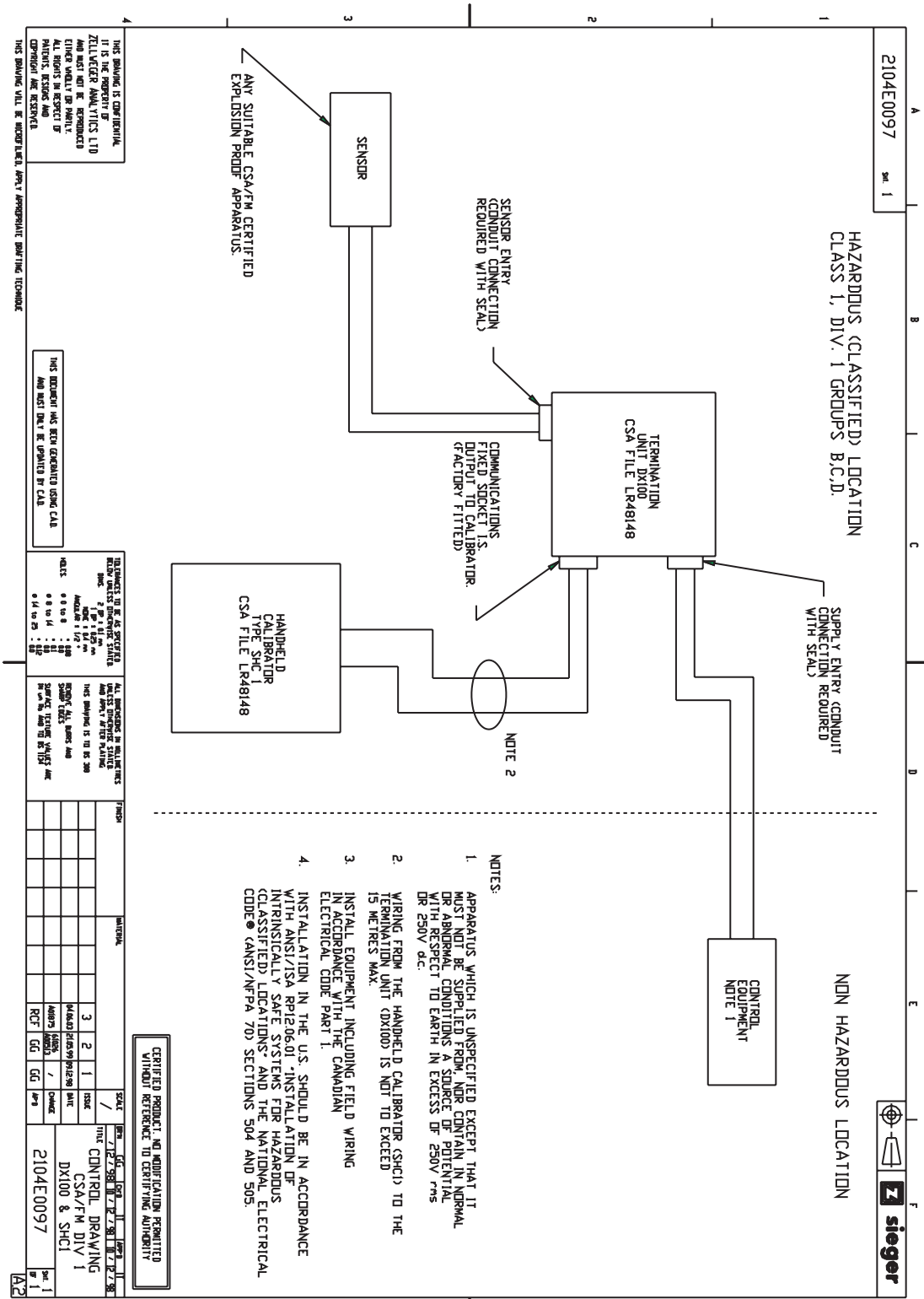

8. CERTIFICATION

With DX100 (M) Termination Unit

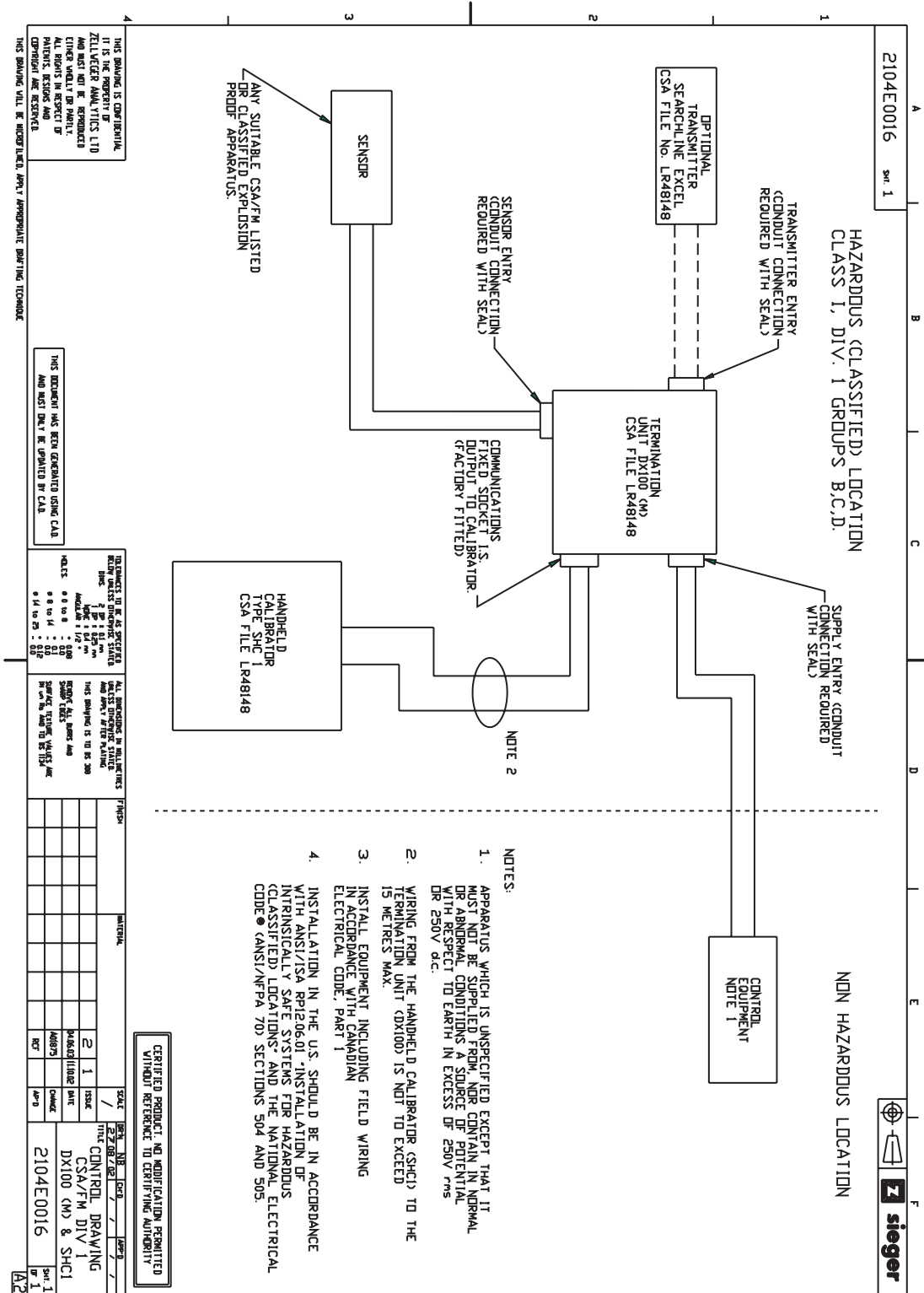

APPENDIX A - HANDHELD INTERROGATOR

A.1 INTRODUCTION

This appendix provides reference information about the SHC1 Handheld Interrogator.

The interrogator provides the user end of a two-way communication link between the Excel system and the operator.

It features facilities which let the operator configure, align, functionally test and diagnose faults in the system.

The appendix gives:

- **an overview of the interrogator features**
- **information about how to connect the interrogator to the Excel systems**
- **basic user tasks, including switching on/off and changing the battery**
- **a detailed description of the menus which the interrogator provides**
- **problem solving information if trouble occurs when using the interrogator**

Details of how to use the interrogator for different tasks with the system are given **Chapter 3** and **Chapter 4** of this handbook.

A.2 OVERVIEW

The interrogator consists of an LCD screen and four keypad buttons. It links to the Excel Receiver unit via an IS connector on the end of a flexible cable connected to the associated junction box.

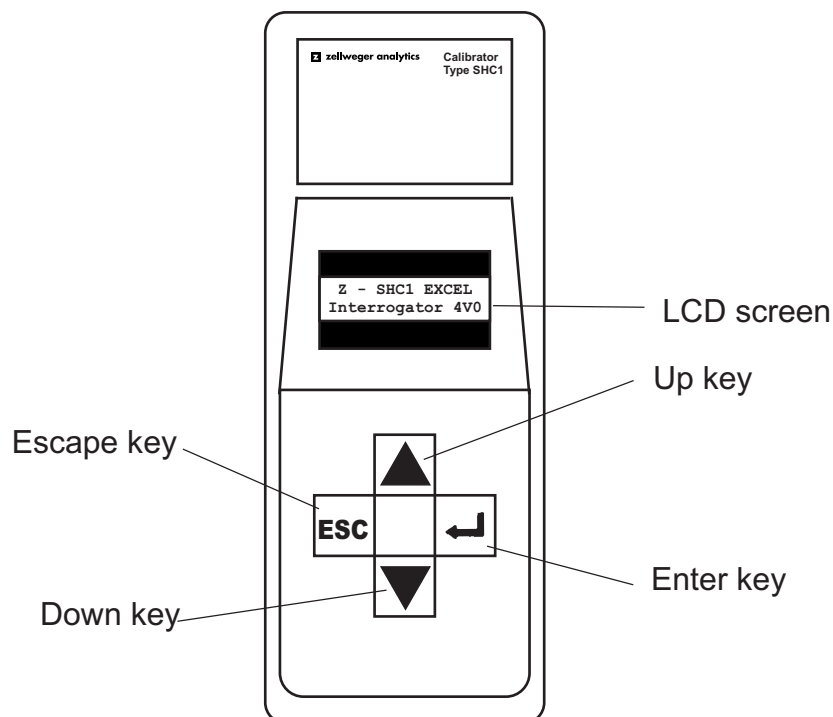

SHC1 Handheld Interrogator Main Features

APPENDIX A - HANDHELD INTERROGATOR

The interrogator is powered by a standard 9V battery and has a management system which reduces power consumption by placing the unit in an idle mode when it is waiting for user input or for a communication operation to complete.

The interrogator also features a 2k byte non-volatile RAM (NV-RAM) split into two sections. These sections are used to store the current operating mode and a backup copy.

Liquid Crystal Display Screen

This screen consists of a two-line, 16-character dot-matrix liquid crystal display (LCD). The screen displays messages which communicate information from/to the user.

It displays a menu system that enables the user to select the command mode for the system, and can also display information about the system configuration and its settings, plus any error messages.

Keypad Buttons

The four keypad buttons are used to provide operator input in response to messages shown on the display.

This includes menu option selections and changing parameter values. The four buttons are:

- ▲ Up Move to the previous menu option, list item, or increase a displayed data value.
- ▼ Down Move to the next menu option, list item, or decrease a displayed data value.
- ESC Escape Quit the current menu level or operation and return to the previous menu, e.g. stop displaying a list, abort a command. No change if already at the top level.
- ↵ Enter Select, i.e. Invoke/accept, the currently displayed menu option, list item, data value, or configuration change.

Note: If the ▲ and ▼ keys are used to advance beyond the end of a list a wrap around to the other end of the list occurs.

A.3 CONNECTION TO SYSTEM

Details of how to connect the interrogator to the Searchline Open-Path and Cross-Duct Excel systems are given in **Chapter 3** and **Chapters 4**. The diagram shows a typical example.

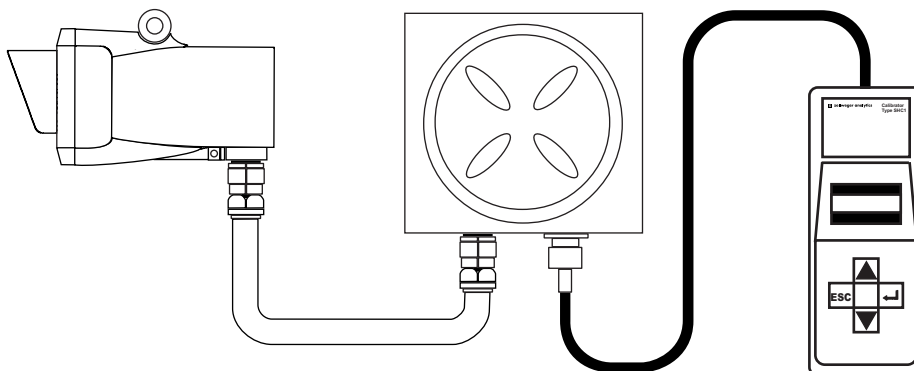

Note: If connecting via a non-ZA junction box then the SHC Protection Device needs to be used.

APPENDIX A - HANDHELD INTERROGATOR

A.4 BASIC USER TASKS

Switching On

- (1) Press **↵** for two seconds.

The unit recalls its previously set operating mode, i.e. **EXCEL**, **OPTIMA** or **OPTIMA PLUS**, and displays the following message for approximately three seconds:

Z - SHC1 EXCEL Interrogator 4V0

The unit then displays the top level of the menu style interface in the following way:

^	Main Display	v
---	-----------------	---

During use the first line of the display shows the current level in the menu tree.

The second line displays the sub menu title, action to be invoked, or data value to be checked/changed.

Note: To change the operating mode at switch-on, e.g. from **OPTIMA** to **EXCEL**, press the **ESC** key whilst the initial message is displayed. This changes the mode and re-displays the message.

Switching Off

- (1) Select the **Power Off** option from the **Main Menu**,
Alternatively press the **↵** and **ESC** buttons simultaneously for a fast power off.

Notes:

1. The unit powers down automatically after five minutes of non-use.
2. The fast power off facility and auto power off are disabled when a menu option is selected that modifies the interrogator's configuration.

Changing the Battery

To fit/replace the battery proceed as follows:

- (1) Loosen the four rear cover screws.
Use a 2.5mm Allen hexagon key.
- (2) Carefully lift the front half of the interrogator away from the rear cover.
Ensure that the flexible connector between the keypad and the electronics module is not damaged.
- (3) Unclip and remove the battery.
- (4) Fit the new battery and cover if fitted.
- (5) Carefully refit the front half of the interrogator to the rear cover.
Ensure that the flexible connector lies flat.
- (6) Tighten the four rear cover screws.

APPENDIX A - HANDHELD INTERROGATOR

A.5 MENUS

The interrogator top level menu structure and menu choices are as follows.

All menu options are implemented by pressing the keypad **↵** key. The menu options and types are shown in the diagram:

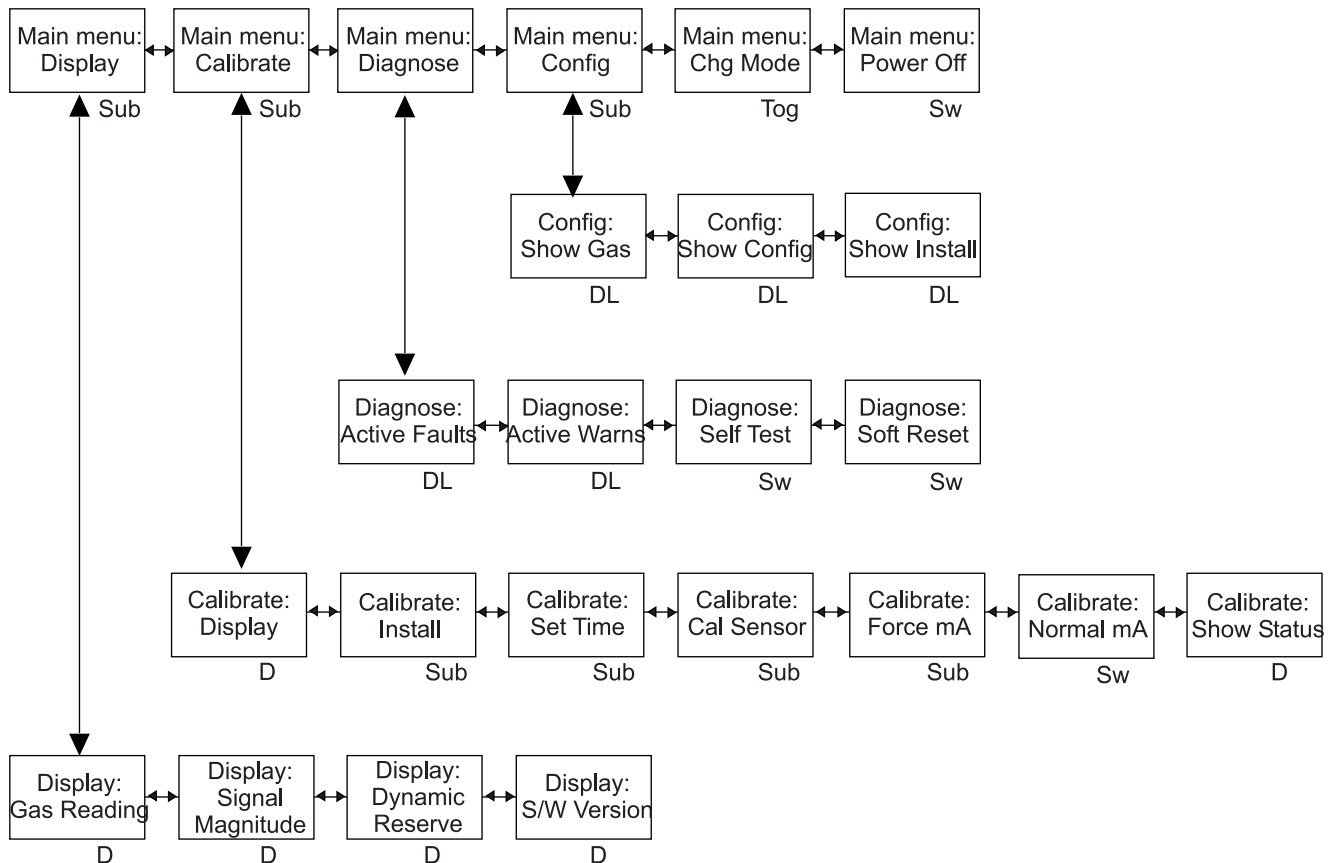

where:

- D** a single set of data is displayed.
 - DL** a list of data is displayed - use the ▲ and ▼ keys to navigate the entries in the list.
 - Sub** another menu of options is displayed when this choice is selected - use the ▲ and ▼ keys to navigate the sub menu choices.
 - Sw** the displayed option is immediately activated.
 - Tog** the displayed option is toggled between three choices using the ▲ and ▼ keys.
- Chapter 3** and **Chapter 4** of this handbook describe how the Interrogator and menus are used when the system is being installed/in use.

APPENDIX A - HANDHELD INTERROGATOR

A.5.1 Main Menu

This menu consists of the following sub menu options:

Display	Display gas and other unit readings.
Calibrate	Install and calibrate the system, force the analogue output, show the calibration coefficients or show the instrument status.
Diagnose	Inspect the fault and warning logs, perform a self-test or perform a soft reset.
Config	Read the configuration parameters of the unit, update the user configuration parameters.
Chg Mode	Toggle the operating mode of the interrogator.
Power Off	Switch the interrogator off.

A.5.2 Display Menu

This sub menu displays gas and other unit readings. It has the following options:

Gas Reading	Display the gas type and system status.
Signal magnitude	Show the level of the sample and reference signals.
Dynamic Reserve	Shows the acceptable drop in signal level before beam block occurs as a percentage of the current signal level.
S/W Version	Displays the system software version and the current time and date.

Gas Reading

Display the gas type and system status. The display is in the following format:

Excel gggggggg rrrrrrr uuuu /
--

where: ggggggggg	Gas name. For a special gas table this shows <Gnnn> where nnn is the identifier.
rrrrrrr	Gas reading.
uuuu	Measurement units.
/	This is a status character which indicates one of the following:
/	- A spinning line shows the system is operating normally i.e. in a fully active state.
 	- A stationery line shows the system is in an inactive state.
W	- Active Warning.
F	- Active Fault.
B	- Beam Block.
A	- Alarm

APPENDIX A - HANDHELD INTERROGATOR

Signal Magnitude

Show the level of the sample and reference signals. The display is in the following format:

Sample: aaaaaaa
Ref: bbbbbbb

where: **aaaaaaa** Signal magnitude for the sample channel.
bbbbbbb Signal magnitude for the reference channel.

Dynamic Reserve

Shows the acceptable drop in signal level before beam block occurs as a percentage of the current signal level. The display is in the following format:

Dynamic Reserve: xxx.xx %
--

where: **xxx.xx** The acceptable drop in signal level before beam block measured as a percentage of the current signal level.

S/W Version

Displays the system software version and the current time and date. The display is in the following format:

Excel S/W vvVvv hh:mm dd/mm/yy

where: **vvVvv** Version number of the Excel system software.
hh.mm System time as hours and minutes.
dd/mm/yy System date as day of the month, month number and the last two digits of the year.

Note: The year 2000 is displayed as 00.

A.5.3 Calibrate Menu

This sub menu is used when installing and calibrating the system. It has the following options:

- | | |
|--------------------|--|
| Display | Display system readings.* |
| Install | Direct the alignment and initialisation of the system.* |
| Set Time | Set the system real time clock time and date. |
| Cal Sensor | Calibrate the system zero.* |
| Force mA | Fix the 4-20mA analogue output at a selected level. |
| Normal mA | Restore the analogue output to its normal output state. |
| Show Status | Show the calibration and configuration status of the system. |

The options marked with an asterisk, (*), require the system's analogue 4-20 output to be inhibited during their operation. Where this occurs then the following sequence is automatically added to the affected operation.

APPENDIX A - HANDHELD INTERROGATOR

Before the selected sub menu operation is started the following message is displayed for at least three seconds:

Inhibiting 4-20
Please Wait

The analogue output is inhibited and the chosen sub menu operation proceeds. After the sub menu operation is completed, or aborted by pressing the **ESC** key, the following message is displayed:

Press Enter To
Release 4-20

Press **↵** to release the 4-20 receiver output and the following message will be displayed for three seconds:

4-20 Released

Display

Display system readings. This choice is the same as the **GAS READING DISPLAY** option on the **DISPLAY MENU**.

Notes:

1. *The 4-20 output is inhibited during the display. See the earlier description.*
2. *No spinning line is displayed as the receiver is not in a fully activated state.*

Install

This choice is used to complete the alignment and commissioning operations after the system is mechanically and electrically installed. It provides a sequential set of operations to:

- **view the system type**
- **set the system path length**
- **perform a system self test**
- **check system alignment**
- **initialise the system and make it live**

Note: The 4-20 output is inhibited during this procedure. See the earlier description.

System Type

The initial display after **Install** is chosen is in the following format:

System Type
tttttttt

APPENDIX A - HANDHELD INTERROGATOR

where: `ttttttt` System type. The system type displayed is one of the following:

Display Text	System Type
Short Range	40m range system
Medium Range	120m range system
Long Range	200m range system
Duct Mount	0.5 - 5m range system

Note: It is not possible to change the system type. This is set during calibration and configuration of the unit at the factory.

Path Length

The following message is displayed:

```
Path Length
^      nnnn      v
```

where: `nnnn` The path length in metres.

The following ranges of path length can be entered for the system types:

System Type	Minimum Range (m)	Maximum Range (m)	Step Size (m)
Short Range	5	40	1
Medium Range	20	120	1
Long Range	20	200	1
Duct Mount	0.5	5	0.1

Self Test

This starts the system self test process.

The following message is displayed:

```
Press Enter to
Perform checks
```

This message is displayed during the self test process after pressing **Enter**.

```
Processing Data
Please Wait
```

This message is displayed for three seconds at the end of a successful self test process.

```
Checks Passed
```

APPENDIX A - HANDHELD INTERROGATOR

Alignment

This starts the alignment process.

The following message is displayed:

Press Enter to
Align Unit

This message displays the system output and reference signal values.

SIG: ■
MAX: ■■

where: ■ A bar graph representing the current signal magnitude - **SIG**:
■■ A bar graph representing the target signal - **TGT**:

Important Notes:

- 1) *The overall objective of alignment is to maximise the **SIG** level. Maximised **SIG** corresponds to optimal alignment.*
- 2) *The Instrument Assisted Alignment (IAA) system only allows Excel to be initialised if the **SIG** level is greater than or equal to the **TGT** level when **Enter** is pressed.*
- 3) *The smallest **TGT** signal level that is initially set will be equivalent to 70% (0.700) of the signal expected for the installation's path length.*
- 4) *The **TGT** level will increase gradually if the current **SIG** level is larger than the **TGT** level. The **TGT** signal level only ever increases. If the current **SIG** level falls below the **TGT** level, **TGT** will remain at its previous highest value. In order to initialise the gas detector the **SIG** level must be brought back above the **TGT** level.*
- 5) *If the **SIG** level is less than 50% of the expected level, the bar graphs are **not** displayed. Instead both **SIG** and **TGT** levels are displayed as **numbers**.*

Options

The approach to mechanical alignment depends on the type of alignment telescope and mounting initially used to set up the Excel gas detector, also see **Chapter 3**.

Bayonet-style Trident-type telescope assembly

If this type of alignment telescope was used with a Trident-type Excel gas detector, there is no need to further optimise the alignment using the SHC1 Handheld Interrogator.

When the **SIG** and **TGT** bar graphs are displayed on the SHC1 screen, **SIG** will always be greater than **TGT** and installation can proceed to the next stage by pressing **Enter** and following step 12.

APPENDIX A - HANDHELD INTERROGATOR

Latch-style Trident-type telescope assembly

If this type of alignment telescope was used with a Trident-type Excel gas detector, there is no need to further optimise the alignment using the SHC1 Handheld Interrogator.

If this type of alignment telescope was used with a non-Trident Excel it may be necessary to further optimise the alignment in the following way in order to achieve best performance.

- (a) After the **SIG** and **TGT** bar graphs are displayed on the SHC1 screen as previously described, let the **TGT** level reach its initial maximum by waiting for approximately 10 seconds.

*During this time the **TGT** level will move up towards the current **SIG** level.*

- (b) Whilst watching the **SIG** level closely, make a **small** mechanical adjustment in either the horizontal or vertical alignment and note whether the **SIG** level goes up or down.
- (c) If the **SIG** level goes **up**, make another **small** mechanical adjustment in the same direction as before.
- (d) If the **SIG** level goes **down**, change the direction of adjustment.

*Maximise the **SIG** level by making **small** adjustments in only **one plane** at a time.*

- (e) When the **SIG** level has been maximised in one plane, make small adjustments in the other plane until **SIG** has been maximised in this plane.
- (f) Repeat steps (b) to (e) until the **SIG** level has been maximised in both planes.

*At this point, **SIG** must be bigger than the initial **TGT** level and any adjustment either side of the current alignment must result in a reduction in signal level.*

If not, repeat steps (b) to (e) until these requirements have been met.

- (g) Lock off the alignment by placing a hex (Allen) key in the pair of grub-screws which control adjustment in a particular plane and simultaneously rotating them in opposite directions.
- (h) Repeat this for the other pair of grub-screws.
- (i) Press **Enter** and the signal levels are checked.

Provided that the **SIG** level is greater than the **TGT** level, the signal check should pass on to the next stage of installation.

Initialisation

This starts the initialisation process. The following message is displayed:

**Press Enter to
Initialise Unit**

This message is displayed during the initialisation process after pressing **Enter**.

**Processing Data
Please Wait**

This message is displayed for three seconds at the end of a successful initialisation process.

APPENDIX A - HANDHELD INTERROGATOR

Unit Initialised

*Note: The Searchline Excel system is **live** after a successful initialisation.*

Set Time

This option lets you set the system s time and date.

The initial display after **SET Time** is chosen is in the following format:

Time HH:MM
^ hh:mm v

where: **hh** Hours.
 mm Minutes.

When first displayed only the current hour is shown.

All settings are adjusted by means of the ▲ and ▼ keys on the keypad.

After setting the hour the minutes are displayed.

After the time has been entered then the same process is used to set the date which is displayed in the following format:

Date DD/MM/YY
^ dd/mm/yy v

where: **dd** Day.
 mm Month.
 yy Last two digits of the year.

Notes:

- 1. The time and date will not be updated unless both are entered and accepted without error.*
- 2. The year 2000 is displayed as 00.*

Cal Sensor

This menu option zeros the system.

Notes:

- 1. The 4-20 output is inhibited during this procedure. See the earlier description.*
 - 2. There must be no gas in the system beam path whilst this procedure is carried out.*
- The following message is displayed:*

Ensure Zero Gas
Press Enter

APPENDIX A - HANDHELD INTERROGATOR

The following message is displayed while the calibration operation is being performed:

```
Processing Data
Please Wait...
```

If the calibration is successful, the following message is displayed for a period of three seconds:

```
Zero Calibrated
```

Force mA

This option allows the system's analogue output signal to be adjusted to a fixed level, e.g. when setting up a system controller. The following message is displayed:

```
O/P current mA
^          mmmmmmm          v
```

where: **mmmmmm** Current to output.

This is adjusted using the ▲ and ▼ keys over the range 1mA to 21mA in steps of 0.1mA.

After adjustment the output is forced to the set level and the following message is displayed:

```
Fixed: mmmmmmm mA
Press Enter
```

where: **mmmmmm** Analogue output current previously set.

Normal mA

This menu option returns the system to its normal analogue output state, irrespective of its previous state. If successful, the following message is displayed for three seconds:

```
4-20mA Released
```

Show Status

This menu option displays the calibration and configuration status of the system. The status information is displayed in the following format:

```
cccccccccccccccccc
ssssssss
```

where: **ccccccc** . . . Title of the calibration status field.
ssssssss Current state of calibration.

The different settings from the list are selected using the ▲ and ▼ keys on the keypad.

APPENDIX A - HANDHELD INTERROGATOR

The calibration status fields and values are given below:

Calibration Status Fields	Display Text	False State	True State
Temperature Cal.	Temp Sensor	Uncalibrated	Calibrated
Zero Calibration	Zero Ratio	Uncalibrated	Calibrated
Span Calibration	Span Sensitivity	Uncalibrated	Calibrated
4-20mA Calibration	Analogue Output	Uncalibrated	Calibrated
Det. Temp. Comp.	T Compensation	Uncalibrated	Calibrated
Det. Sens. Comp.	Det Sensitivity	Uncalibrated	Calibrated
Installation	Installation	Required	Complete
Valid Date Time	Date and Time	Estimated	Set
Loop Test	Analogue Check	Failed	Passed

A.5.4 Diagnose Menu

This sub menu has the following options:

- Active Faults** Display the active faults in the system.
- Active Warns** Display the active warnings in the system.
- Self Test** Perform a diagnostic system self test.
- Soft Reset** Reset the system.

Active Faults

This menu option displays operational faults when the system is in service.

If there are one or more faults present, then the faults are displayed one at a time.

Use the ▲ and ▼ keys to navigate the list.

If no active faults are present the display shows the following for three seconds:

None Present

The **Diagnose** sub menu is then displayed.

If there are one or more faults present, the display shows:

F-hh:mm DD/MM/YY
eeeeeeeeeeeeeeee

- where:
- F** Indicates that the message displayed is a fault.
 - hh:mm** Time the fault occurred.
 - DD/MM/YY** Date the fault occurred.
 - eeeeeee . . .** Fault description. See the following table for a list of error messages.

See also **Chapter 6, Problem Solving.**

APPENDIX A - HANDHELD INTERROGATOR

Display Text	Fault Description	Meaning
Bad 4-20mA Loop	ERR_EXCEL_LOOP_FAULT	A fault has occurred in the 4-20mA signal loop.
DSP Fault	ERR_EXCEL_DSP_FAULT	Fault on the gas detector's digital PCB.
Hardware Fault	ERR_EXCEL_HW_FAULT	A hardware fault has occurred.
NV-RAM Fault	ERR_EXCEL_FRAM_FAULT	A fault has been detected in the unit's NV-RAM.
RTC Fault	ERR_EXCEL_RTC_FAULT	The time and date record stored by the RealTime Clock (RTC) has been lost.
Software Fault	ERR_EXCEL_SW_FAULT	An gas detector software error has occurred.
Supply Fault	ERR_EXCEL_SUPPLY_FAULT	Incorrect supply voltage reaching the gas detector.

Active Warns

This menu option displays the active warnings in the system. They are displayed in the same way as described for **Active Faults** except that a **W** is displayed instead of **F** on the first line of the display.

Display Text	Fault Description	Meaning
Alarm	ERR_EXCEL_LOG_ALARM	The Excel log has become damaged.
Bad Temperature	ERR_EXCEL_TEMPERATURE_LIMIT	Unit has been operated at a temperature outside its specified and certified range.
Baseline Drift	ERR_EXCEL_DRIFT_LIMIT	Drift of unit's baseline.
Beam Blocked	ERR_EXCEL_BEAM_BLOCKED	The infrared beam between the Transmitter and Receiver has become blocked.
Neg Gas Reading	ERR_EXCEL_NEGATIVE_DRIFT	Negative drift of gas detector's zero position.
Not Installation	ERR_EXCEL_BAD_INSTALLATION	Incorrect gas detector installation has occurred.
Overrange	ERR_EXCEL_OVERRANGE	An overrange signal has occurred.
Power Failed	ERR_EXCEL_LOG_POWER_FAIL	The gas detector has suffered an internal power failure.
Reset Occurred	ERR_EXCEL_RESET	A gas detector reset has occurred.
Time Adjusted	ERR_EXCEL_LOG_TIME_ADJUST	The Excel log time has been changed.
Uncalibrated	ERR_EXCEL_UNCALIBRATED	The gas detector requires calibration.
Volt Ref Fault	ERR_EXCEL_VOLTAGE_REF_FAIL	Voltage reference fault detected.

Self Test

This option lets you start a system diagnostic self test.

The following message is displayed during the self test process:

<p>Processing Data Please Wait</p>
--

APPENDIX A - HANDHELD INTERROGATOR

The following message is displayed for three seconds at the end of a successful self test process.

Checks Passed

Soft Reset

This option lets you reset the system.

This message is displayed during the reset process:

Processing Data
Please Wait

The following message is displayed for three seconds when the process is completed:

Unit Reset

A.5.5 Config Menu

This sub menu lets you check the configuration parameters of the unit and update the user configuration parameters. It has the following options:

- Show Gas** Show the gas related configuration parameters.
- Show Config** Show the user related configuration parameters.
- Show Install** Show the installation related configuration parameters.

Show Gas

This option displays the useful gas table configuration parameters in the following way:

cccccccccccccccc
vvvvvvvvv

where: **ccccccc . . .** Title of the configuration setting.
 vvvvvvvvv Setting value.

Note: The settings are not field configurable:

Gas Configuration Parameters	Display Text	Min Value	Max Value	Step Size
Gas ID	Gas Ident	0 1 = Methane 2 = Ethane 3 = Propane 4 = Butane 5 = Pentane 6 = Hexane all other IDs shown as G<nnn>	255	1

APPENDIX A - HANDHELD INTERROGATOR

Gas Units	Gas Units	LELm, PPMm, UEGm, or Vvm %LEL (Cross-Duct only)
Effective Full Scale	Gas Full Scale	0.1 100000 0.05

Show Config

This option displays the configuration parameters the user can set in the same way as for the **Show Gas** option. The configurable settings and values are shown in the following table:

Configuration Parameters	Display Text	Min Value	Max Value	Step Size	Default Values
Protocol Address	Digital Address	0	255	1	0
Time to Block	Block Warn Time	5s	600s	5s	30
Time to Fault	Block Fault Time	0s	600s	5s	120
Max Response	Maximum T90	1s	60s	1s	60
Analogue Style	Analogue Mode	Alarm or Continuous			C
Inhibit Current	Inhibit mA	0mA	3mA	0.05mA	2.0
Block Current	Blocked mA	0mA	4mA	0.05mA	2.5
Low Signal Current	Low Signal mA	0mA	4mA	0.05mA	3.0
Low Signal Level	Low Signal %	0%	90%	1%	33%
Alarm Threshold	Alarm Threshold	10%	100%	1%	20%
Report fault due to blockage	RPRT Blocked Fault	Enable or Disable			E

Show Install

This option displays the installation configuration parameters in the same way as for the **Show Gas** option. The configurable settings and values are shown below:

Installation Configuration Parameters	Display Text	Description
System Type	System Type	Short Range Medium Range Long Range Duct Mount
Path Length	Path Length	5m min. 200m max. 1m step 0.5m min. 5m max. 0.1m step

APPENDIX A - HANDHELD INTERROGATOR

A.5.6 Chg Mode

This menu option toggles the operating mode of the interrogator between **Excel**, **Optima** and **Optima Plus** to match the gas detector it is attached to. When invoked the mode is displayed in the identification banner (the same as the one displayed when the unit is switched on) for three seconds as follows:

Z - SHC1 aaaaaa Interrogator 4V0

where: aaaaaa The type of gas detector that the interrogator is currently set to, i.e. **Excel**, **OPTIMA** or **OPTIMA PLUS**.

A.5.7 Power Off

This menu option switches the interrogator off.

Alternatively press the **↵** and **ESC** buttons simultaneously for a fast power off.

Notes:

1. The unit powers down automatically after five minutes of non-use.
2. The fast power off facility and auto power off are disabled when a menu option is selected that modifies the unit's configuration.

A.6 PROBLEM SOLVING

Interrogator problems that occur during communication with the system or as a result of a command failure will be displayed in the following format:

Error: eee ssssssssssssssss

where: eee Error code.
ssssssss . . . Textual description of the error.

If an error message of this kind is displayed note down the error code and text description and contact Zellweger Analytics.

APPENDIX B - GLOSSARY

B.1 TERMINOLOGY

Ex d

Flame proof or explosion proof within the confines of European standards EN50014 and EN50018. An enclosure that can withstand the pressure developed during the internal explosion of an explosive mixture and that prevents transmission of the explosion to the explosive atmosphere surrounding the enclosure.

Ex e

Increased safety within the confines of European standards EN50014 and EN50019 applied to electrical apparatus that does not produce arcs or sparks in normal service, in which additional measures are applied so as to give increased security against the possibility of excessive temperatures.

Instrument Assisted Alignment (IAA)

A method of commissioning the Excel system using the associated electronic Handheld Interrogator device. The process will not allow the Excel system to initialise unless the alignment of the Receiver and Transmitter is correct and the signal strength is correct.

IS

Intrinsically safe, apparatus in which the circuits themselves are incapable of causing ignition of a flammable gas.

Lower Explosive Limit (LEL)

The volume of flammable gas or vapour in air below which an explosive gas atmosphere will not be formed.

RS485

An industry-wide serial communication link protocol.

Turbo heating

Increased Transmitter window heating at low operating temperatures.

B.2 MEASUREMENT UNITS

LEL.m

Lower Explosive Limit metres. Open path detectors measure the amount of gas present in the beam. However, they cannot discriminate between a low concentration gas cloud over a large area and a high concentration gas cloud in a small area. % LEL has little meaning in this situation and so gas readings of LEL.m are used. LEL.m is calculated by multiplying the size of a gas cloud by its concentration.

APPENDIX B - GLOSSARY

An open path alarm set at 1 LEL.m would be triggered by any of the situations shown below:

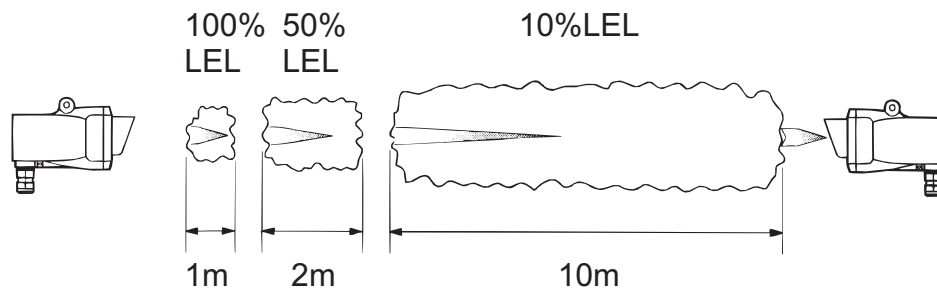

LEL.m monitoring is particularly beneficial while the Excel gas detector is protecting the perimeter of a plant or process, often reducing the quantity of point detectors required. The open path LEL.m system has the ability to detect leaks that point detectors may miss due to prevailing or changing wind directions, and can provide early warning of a dilute gas cloud when point detectors may not register any gas presence.

Path Averaged %LEL (%LEL/m)

FM versions of Excel Cross-Duct signal a reading which is the path averaged %LEL (Units of measure are %LEL/m). This reading is the average %LEL concentration in the duct, based upon the assumption that the gas concentration in the duct is uniform. Effectively, the reading is calculated as below:

$$\text{Path Av \%LEL} = \frac{\text{Number of LEL.m in duct} \times 100 (\%)}{\text{Duct Width (m)}}$$

Example

In a 1 metre duct, a 10%LEL/m reading will be signalled for 1 metre of 10%LEL gas, or 0.5 metres of 20%LEL gas, or 0.1 metres of 100%LEL gas. (This behaviour is similar to that of conventional open path gas detectors which output readings in LEL.m, see previous definition)

Recommended alarm thresholds are 20 %LEL/m and 40%LEL/m.

When readings are displayed on the FM version of the SHC1 Handheld Interrogator, the %LEL/m unit is displayed as %L/m.

B.3 ABBREVIATIONS

CENELEC	European Committee Standardisation
CSA	Canadian Standards Association
DSP	Digital Signal Processor
EMC	Electro-Magnetic Compatibility

APPENDIX B - GLOSSARY

IAA	Instrument Assisted Alignment
IP	Ingress Protection
IR	Infrared
IS	Intrinsically Safe
FM	Factory Mutual
LEL	Lower Explosive Limit
LR	Long Range
MR	Medium Range
NPT	National Pipe Thread
RFI	Radio Frequency Interference
SHC	Sieger Handheld Calibrator
SR	Short Range
UL	Underwriters Laboratories

APPENDIX C - ACCESSORIES & SPARE PARTS

C.1 SYSTEM UNITS

The following table lists the different types of system units and provides the part numbers for the various certification options.

All types of Transmitters and Receivers include conduit and glands. Open-Path Transmitters and Receivers do not include mounting plates and brackets.

Gas detector unit	CENELEC Part Number	UL Part Number	CSA/FM Part Number
<i>Open-Path Transmitters</i>			
Short Range	2104B2071	2104B3001	2104B3201
Medium Range	2104B2081	2104B3011	2104B3211
Long Range	2104B2091	2104B3021	2104B3221
<i>Open-Path Receivers (Current Source)</i>			
Short Range	2104B2111	2104B3101	2104B3301
Medium Range	2104B2131	2104B3111	2104B3311
Long Range	2104B2151	2104B3121	2104B3321
<i>Open-Path Receivers (Current Sink)</i>			
Short Range	2104B2112	2104B3102	2104B3302
Medium Range	2104B2132	2104B3112	2104B3312
Long Range	2104B2152	2104B3122	2104B3322
Long Range (UL)		2104B2154	
<i>Cross-Duct Transmitter/Receivers</i>			
Transmitter	2104B2530	2104B2601	
Receiver (Current Source)	2104B2531	2104B2602	
Receiver (Current Sink)	2104B2532	2104B2603	

C.2 GENERAL

Description	Part Number
<i>Open-Path</i>	
Alignment Telescope for Long Range	2104B2322
Alignment Telescope for Short Range	2104B2321
Functional test filter, A1 butane	2104N2204
Functional test filter, A1 ethylene	2104N2221
Functional test filter, A1 methane	2104N2201
Functional test filter, A1 methanol	2104N2225
Functional test filter, A1 propane	2104N2203

APPENDIX C - ACCESSORIES & SPARE PARTS

Description	Part Number
Functional test filter, A2 butane	2104N2214
Functional test filter, A2 ethylene	2104N2231
Functional test filter, A2 methane	2104N2211
Functional test filter, A2 methanol	2104N2235
Functional test filter, A2 propane	2104N2213
Insulation/Mounting Bracket Assembly for Long Range	2104B2302
Insulation/Mounting Bracket Assembly for Short Range	2104B2301
Mounting Plate, Stainless Steel	2104D0237
Cross-Duct	
Functional test filter set (8 filters)	2104N3000
Retro-reflector mounting plate for Long Range	2104D2537
Retro-reflector, double-glazed pane for Long Range	2104D2535
Retro-reflector mounting plate for Short Range	2104D2536
Retro-reflector, double-glazed pane for Short Range	2104D2534
Mounting plate, Cross-Duct, Stainless Steel	2104D2505
Support strap, Cross-Duct mounting plate	2104D2506
Support strap, Cross-Duct retro-reflector for Long Range	2104D2542
Support strap, Cross-Duct retro-reflector for Short Range	2104D2541
Junction Boxes	
DVC100 Marine Excel	04220-A-1001
DX100 (aluminium version of DVC100) CSA/FM Certified	2104B2360
DX100 (aluminium version of DVC100) UL Certified	2104B2361
DX100 (M) UL Certified	2104B2382
DX100 (M) CSA/FM Certified	
Hawke Junction Box PL-612	00780-A-0100
Killark KHB Junction Box	210-190-045
Other	
Gassing Cell	2104B2326
Gassing Nozzle	2108D0271
Handheld Interrogator SHC1, ATEX Certified	2104B2357
Handheld Interrogator SHC1, UL Certified	2104B2351
Handheld Interrogator SHC1, CSA/FM Certified	2104B2354
Protection Device SHC	04230-A-1025
Sun Shade	2104B2323

For test filters for the complete range of gases, please contact Customer Service.

Find out more

www.honeywellanalytics.com

Customer business centre

Europe and the rest of the world

Honeywell Analytics AG

Wilstrasse 11-U11

CH-8610 Uster

Switzerland

Tel: +41 (0)44 943 4300

Fax: +41 (0)44 943 4398

sales@zelana.co.uk

Customer business center

Americas

Honeywell Analytics Distribution, Inc.

400 Sawgrass Corporate Pkwy

Suite 100

Sunrise, FL 33325

USA

Tel: +1 954 514 2700

Toll free: +1 800 538 0363

Fax: +1 954 514 2784

sales@zelana.com

www.honeywell.com

Issue 09 12/2005

H_MAN0530_V1

Searchline Excel

2104M0506

© 2005 Honeywell Analytics

Honeywell