

This step-by-step guide describes set-up procedures to help provide a safe parking garage while minimizing energy costs associated with ventilation and heating.

CO and NO₂ Monitoring Systems for Parking Structures



Codes and Standards

Step 1: Determine the reason(s) why you want to detect the presence of carbon monoxide.

- **Safety:** In any facility where people are working or the public and tenants may be active, there must be due diligence on the part of the owner to assure a safe breathing environment.
- **Economics:** To provide fresh air in a facility where vehicles are present, a pre-determined air change per hour is required. This can be expensive for a number of reasons:
 - 1) The electrical energy required to run the fans can be high.
 - 2) The fans run continuously which incurs wear and shortens motor life.
 - 3) The frequency of required maintenance is higher for belt and lubrication services.
 - 4) The heat loss in a garage is higher with the high volume of air changes.
- **Aesthetics:** In private facilities, the outside fan noise and loss of heat within the garage can affect tenant satisfaction.

In parking structures, CO and NO₂ are two of the most abundant airborne contaminants and poses significant safety concerns. The CO and NO₂ levels must be controlled or ventilated when concentrations approach unsafe levels.

Various gas monitors are available for use in parking structure applications. The specifics of the design determine what type of monitor or monitoring system best suits the application. This detailed, easy-to-use guideline assists the design engineer in the selection of an optimal gas detection solution.

Step 2: What the ASHRAE handbook says about carbon monoxide detection in parking garages:

- "The operation of automobiles presents two concerns. The most serious is the emission of carbon monoxide, with its own risks."
- "The second concern is the presence of oil and gasoline fumes...the ventilation required to dilute carbon monoxide to acceptable levels will also control the other contaminants satisfactorily."
- "To conserve energy, fan systems should be controlled by carbon monoxide meters with multiple fan or variable speed stages for larger systems, if permitted by local codes. In multi-level parking garages or single-level structures of extensive area, independent fan systems, each under individual control, are recommended."
- "The ventilation system in parking garages, in general, moves large quantities of air through large openings without extensive ductwork. These conditions, in addition to the highly reverberant nature of the space, contribute to high noise levels."

Step 3: Building codes and carbon monoxide monitoring

- International Mechanical Code - Section 403.5
Public garages - Mechanical ventilation systems for public garages are not required to operate continuously where the system is arranged to operate automatically upon detection of a concentration of carbon monoxide of 25 ppm by approved detection devices.
- Uniform Building Code - Section 705 - In all parking garages...automatic CO sensing devices may be employed to modulate the ventilation system to maintain a maximum average of CO of 50 ppm during any eight-hour period, with a maximum average concentration not greater 200 ppm for a period not exceeding one hour...
- State, municipal and other building codes
- Most state, and local municipal building codes recognize and recommend using carbon monoxide monitors in enclosed parking garages. If the building code in your area does not have any provisions for CO monitoring, do not forget that carbon monoxide is still a very dangerous gas to personal health and safety. Therefore, the use of common sense by design engineers is still the best "building code" to use.



The 301C is able to monitor up to 96 hardwired transmitters and has a series of relays which can activate alarms and/or ventilation equipment as required.

Codes, Standards and Sequence of Operation



Step 4: Carbon monoxide and nitrogen dioxide toxicity levels and related health symptoms

Table 1 – Carbon Monoxide Toxicity Levels and Related Health Symptoms

CO Level in Air		Toxic Symptoms and Time Breathed
In parts per million	In %	
12,800 ppm	1.28%	Death within 1 to 3 minutes
6,400 ppm	0.64%	Headache, dizziness in 1-2 minutes. Death in 10-15 minutes
3,200 ppm	0.32%	Headache, dizziness, nausea within 10 minutes. Death within 30 min.
1,600 ppm	0.16%	Headache, dizziness, nausea within 20 minutes. Death within 2 hours
800 ppm	0.08%	Headache, dizziness, nausea within 45 minutes, convulsions. Coma within 2 hours
400 ppm	0.04%	Frontal headache 1-2 hours, widespread 2 ½ to 3 ½ hours
200 ppm	0.02%	Slight headache, tiredness, dizziness, nausea after 2-3 hours

Nitrogen Dioxide Toxicity Levels and Related Health Symptoms

NO ₂ Level in Air	Toxic Symptoms and Target Organs
5 ppm	Chronic bronchitis, emphysema
5 ppm	Eye, nose, and upper respiratory irritation
5 ppm	Chronic bronchitis, emphysema
5 ppm	Eye, nose, and upper respiratory irritation
5 ppm	Chronic bronchitis, emphysema
5 ppm	Eye, nose, and upper respiratory irritation
1 ppm	Mild headache
1 ppm	Acute pulmonary edema; lower respiratory irritation (cough, dyspnea)
1 ppm	Eye, nose, and upper respiratory irritation
0.2 ppm	Lower respiratory irritation

- Carbon monoxide poisoning is a form of asphyxiation. Carbon monoxide combines with hemoglobin, the oxygen-carrying constituent of blood, 210 times more readily than does oxygen. Carboxyhemoglobin is then formed. Carbon monoxide lowers the oxygen carrying capacity of blood and interferes with necessary gaseous exchange functions.
- Human health effects can vary significantly based on overall state of health, sex, age and weight.
- Many studies have shown that the CO content in exhaust gases of individual vehicles varies greatly. This variation is caused by such factors as the age of the vehicle, carburetor adjustment or injector condition, quality of fuel, engine horsepower, level of maintenance, and differing driving habits of motorists.
- Levels of carbon monoxide in garages vary depending on:
 - 1) Number of cars running
 - 2) Length of travel and operation time of cars in the garage
 - 3) Emission rate of vehicle
 - 4) Acceptable contaminant level within a given facility

Sequence of Operation

Step 5: Carbon monoxide alarm levels and recommended sequence of operation

- First alarm level:
 - 1) Set at low concentration. See Table 2 for recommended low alarm level).
 - 2) Gas monitoring system shall be able to actuate exhaust fans and outside air intake devices to bring the carbon monoxide level down to an acceptable level.
 - 3) Optional: if the parking structure is equipped with either two-speed fans or with a second set of fans, only the first speed of fans or the first set of fans should be actuated.
- Second alarm level:
 - 1) Set at high concentration. See Table 2 for recommended high alarm level).
 - 2) Ventilation equipment previously actuated at low level in the parking garage shall remain operational.
 - 3) Optional: if the parking structure is equipped with either two-speed fans or with a second set of fans, they should be activated at full speed or all fans should be activated.
 - 4) Activation of strobe light (red) and horn might be required.
 - 5) People might be required to evacuate the parking garage.

- Monitoring system malfunction:
 - 1) Activate a buzzer inside the gas detection system controller.
 - 2) May notify the building automation system (if available) through a fault relay of the controller.
 - 3) Secondary activation might be required: warning strobe light (blue).

Step 6: Mechanical ventilation considerations

- Two main factors are required to size the ventilation system:
 - 1) The number of cars in operation
 - 2) The carbon monoxide emission quantities
- Most codes simplify this estimate by requiring four (4) to six (6) air changes per hour for fully enclosed garages. Consult local codes for the specific requirements.
- The carbon monoxide monitoring system must be capable of activating both the exhaust fan(s) and the air intake device(s) such as outside air louvers/dampers and make up air units
- IMPORTANT: As per the Uniform Mechanical Code: Connecting offices (to parking garage), waiting rooms, ticket booths, etc., shall be supplied with conditioned air under positive pressure.



The E²Point utilizes cutting edge technology in order to accurately and reliably monitor carbon monoxide and Nitrogen Dioxide (diesel fumes) levels.

Selection and Location



Table 2 – Alarm Levels and National Standards for CO Exposure Levels

CO level in Air	Standard and Regulation	Alarm level
200 ppm	NIOSH – National Institute for Occupational Safety and Health Short term exposure limit (15-minute maximum exposure level)	Good for high level alarm setpoint. Maximum concentration allowable high alarm.
50 ppm	OSHA – Occupational Safety and Health Administration The maximum allowable concentration for a worker's continuous exposure in any eight hour period.	Acceptable low level alarm setpoint. Maximum concentration for low alarm.
50 ppm	UMC – Uniform Mechanical Code Recommends to activate the mechanical ventilation when CO is monitored in a parking structure	Acceptable low level alarm setpoint. Maximum concentration for low alarm.
35 ppm	EPA – Environmental Protection Agency Recommends 35 ppm or lower as an ambient air quality goal averaged over one hour	Acceptable for low level alarm setpoint.
35 ppm	NIOSH – National Institute for Occupational Safety and Health PEL-TWA : 35 ppm is the maximum allowable concentration for a worker to be exposed to in any eight hour period.	Acceptable for low level alarm setpoint.
25 ppm	ACGIH – American Conference of Governmental Industrial Hygienists TLV-TWA: 25 ppm is the maximum allowable concentration for a worker's continuous exposure in any eight hour period.	Ideal low level alarm setpoint. Minimum concentration for low alarm.
25 ppm	IMC – International Mechanical Code Recommend to actuate the mechanical ventilation when CO is monitored in a parking structure	Ideal low level alarm setpoint. Minimum concentration for low alarm.
9 ppm	EPA – Environmental Protection Agency Recommends 9 ppm or lower as an ambient air quality goal averaged over eight hours.	Too low to be a valuable alarm setpoint. Normally used as being the maximum allowable concentration for office spaces.

Step 7: Interlock of the mechanical ventilation with the carbon monoxide monitoring system

The CO monitoring system shall activate the mechanical ventilation by using either:

- Dry contacts through magnetic starters
- Dry contacts through motor control center (MCC)
- Dry contacts and/or analog outputs (4-20 mA) through the Building Management System (BMS)
- Analog outputs (4-20 mA) modulating the speed of the fans through variable frequency drives (VFD)

The carbon monoxide monitoring system must be capable of activating both the exhaust fan(s) and the air intake device(s) such as outside air louvers/dampers and make up air units

Equipment Selection and Location: Central Panel and Output Module

Step 8: Monitoring System Selection

- Stand-alone monitors: These are usually single points for smaller applications (small number of monitoring points). They are real-time reading with a limited amount of outputs and no moving parts (less maintenance).
- Network monitoring system: These are for multiple sensing points usually being larger

applications. They are real-time reading with several programmable outputs and no moving parts (less maintenance)

Step 9: Gas detection central panel and relay module

- Must be located out of reach of the general public.
- Preferably located inside or close to the motor control center or in connecting offices.
- The controller shall allow programmable alarm levels through relays.
- Addressable transmitters are daisy-chained through a RS-485 communication protocol to the controller.
- The controller module and programming should be accessible only by using the proper password.
- Shall be capable of averaging / zoning.
- Optional 4-20mA / digital input card to allow fan's current sensor to be connected to the controller.

Step 10: Self-test diagnostics with malfunction warning

- Not all monitors on the market offer these features.

- These features insure protection at all times.
- Checks operating status of the monitor itself.

Step 11: Output signals

- Alarm relay output: At least two are required (low and high levels).
- Failure relay output: Only one is required (indicate monitor failure).
- Analog output: provides one 4-20 mA per output sensor or provides the highest concentration, the lowest concentration or the average concentration of CO for a group of sensors (normally interlocked with The Building Management System).

Sensors



Figure 1 – Typical carbon monoxide monitoring system for a three level parking structure

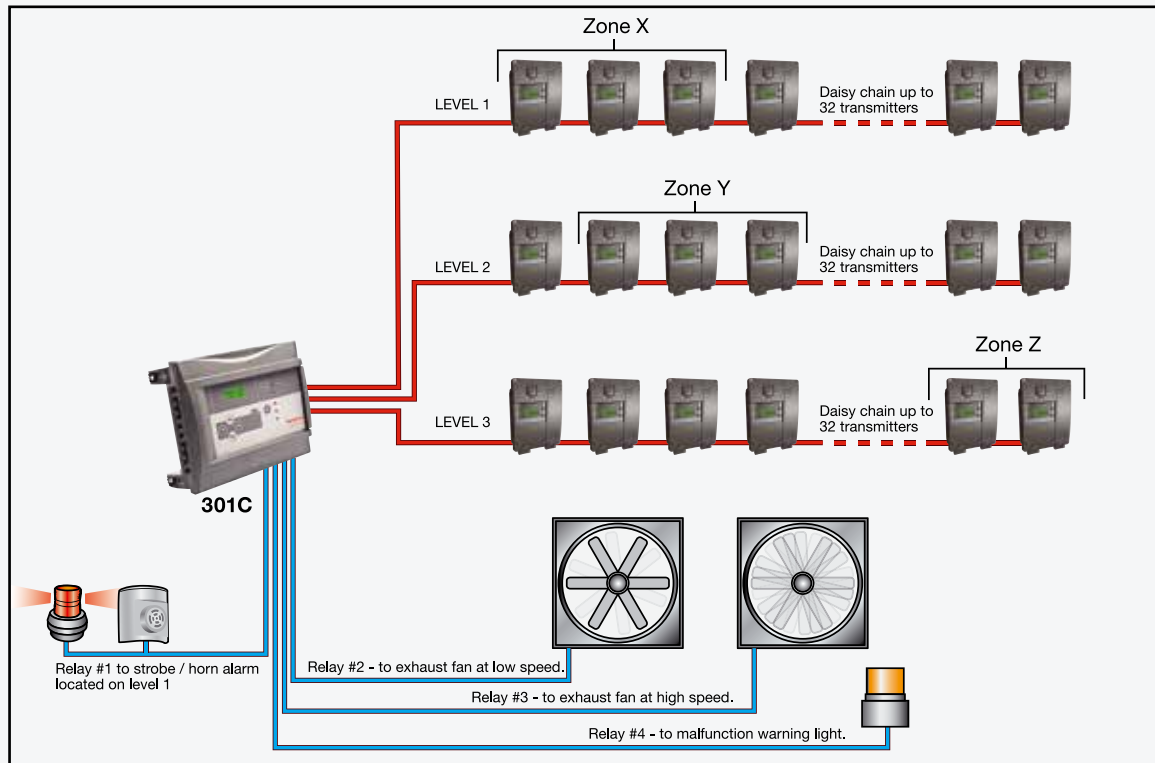

Sensors

Step 12 : Selecting the right sensing element

Table 3 – Sensing element (sensor) selection criteria

Category/Concern	Sensing technology	
	Electrochemical	Solid State (CMOS – Complementary Metal Oxide Semiconductor)
Principle of detection	Carbon monoxide diffuses into the sensor reacts at the surface of the sensing electrode, by oxidation or reduction, causing a current to flow between the electrodes through the external circuit. The current is proportional to the concentration of carbon monoxide and can be measured across a load resistor in the external circuit.	The sensing technology is also known under the name of Solid State Sensor. The semi conductor material and electrodes are deposited on ceramic tubular former. It obtains a weak electro-conductivity in a normal atmosphere but increases its conductivity following the presence of carbon monoxide.
Sensitivity - The sensitivity of any sensing device is defined as the amount of input (material being measured) necessary to generate a certain change in output signal Detection limit - The most common measure of how "sensitive" a detector can be is the detection limit, which is usually defined as the minimum amount of gas a sensor can sense that gives a signal at least two times the background noise level	Sensitive to 1 ppm of carbon monoxide	Has low sensitivity and a high detection limit.
Selectivity - Selectivity can be defined as the ability to detect only the gas of interest without interference from other compounds that may be present in the area.	Gas specific No cross sensitivity	Gas generic Reacts frequently to many other chemicals, humidity levels and temperature changes, causing nuisance or false alarms
Calibration intervals	12-18 months	6-8 months
Cost	E ³ Point slightly more expensive to initially purchase but lower maintenance costs	Less expensive to purchase but costly to maintain and can cause unnecessary exhaust fan cycling

Sensors



Step 13: Quantity of sensors and plan location

The quantity of sensors is determined by the following rules of thumb:

- 1) The radius of coverage is 15.2 m (50 feet) per carbon monoxide monitor or 2,310 sq.m (7,580 sq.ft).
- 2) Use open interior support columns as much as possible to maximize the radius of coverage not walls.
- 3) Each level of the parking structure must be totally covered without overlapping the coverage of the sensors. See Figure 2.

Step 14: Height of sensors

The relative density of carbon monoxide compared to air of carbon monoxide is 0.957 (AIR =1). The carbon monoxide will disperse evenly in the air. The carbon monoxide monitors must be located as specified by your region's building code. If not specified contact your local Honeywell Analytics representative.

Accessories

Step 15: Audible and visual alarm devices

- In general, the mechanical ventilation should be able to evacuate the carbon monoxide out of the parking structure fast enough to maintain the level below 200 ppm. The following are examples where the carbon monoxide level may reach concentrations above 200 ppm:
 - 1) Retrofit of a garage where the ventilation system is not adequate
 - 2) During a major event such as a sporting event or concert where people are leaving the parking garage within a very short period of time
 - 3) Some local codes don't allow carbon monoxide concentrations above 100 ppm. It might be difficult even for the best mechanical ventilation systems to keep the level that low.
- For all of the above mentioned reasons, an audible and/or visual alarm might be required to notify the proper personnel to take corrective actions including possibly evacuating the parking structure.
- Audible and visual alarm devices must be installed in a way to warn workers about high CO levels

- Among the best suitable places for alarm devices are ticket booths and parking garage supervisor/operator offices
- The selection depends on the type of facility and the purpose of the alarm.

Visual

- 1) Flashing beacons (stackable beacons can be used when multiple visual alarms are required)
- 2) The recommended status mode colors for beacons (stackable or individual) include:

Blue: Carbon monoxide monitoring system malfunction

Amber: Low carbon monoxide concentration

Red: High carbon monoxide concentration

Audible

- 3) The sound level should vary depending on the location of the audible alarm and its purpose
- 4) The audible alarm can be integrated with the beacons or remote annunciators or can be separate

Step 16: Warning signs

- Warning signs should clearly identify the meaning of all system status from visual and audible alarm devices.
- Warning signs should be located close to every alarm devices.
- The signs should be at least 40 cm square (16 in. square).
- Black engraved letters on white bond.

Step 17: Special environment and accessories

Depending on the parking structures, special requirements may include:

- Nema 4X enclosures: essential when sensors are exposed to dust, dirt, light splashing. ("X" designates resistance to corrosive agents.)
- Splash Guard: (ECLAB) Provides enhanced protection from water hose spray (when washing cars or parking garage walls).
- Low temperature assembly: special treatment should be applied to the electronic component of the sensors to insure proper functioning of the unit even at low temperature (rated to -20° Celsius or -4° Fahrenheit).

Figure 2 - Sensor placement diagram for one level of a parking structure

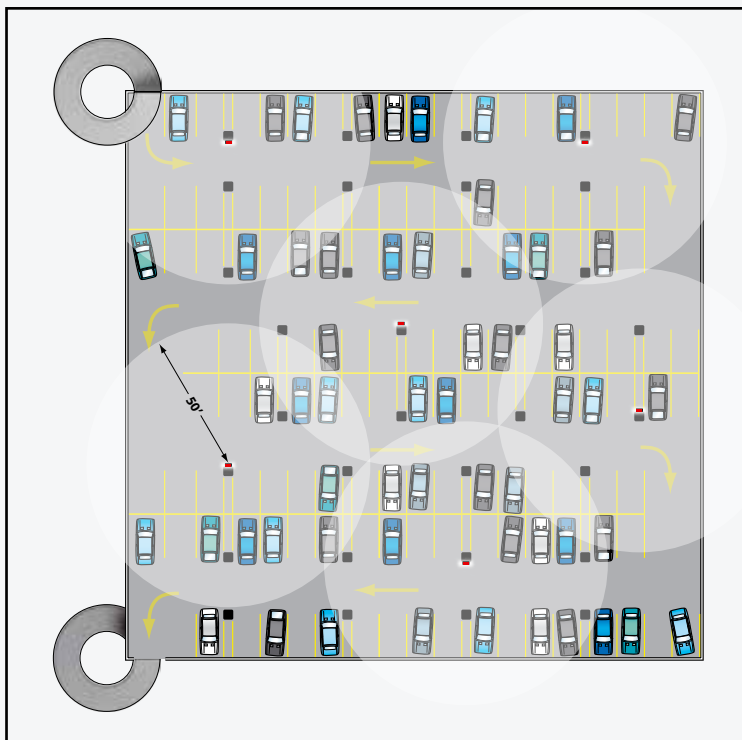

Sensors



Closeout Procedures

Step 18: Start-up and commissioning

Engage a factory-authorized service representative to perform the following:

- 1) Inspect field-assembled components, equipment installation, and electrical connections for compliance with requirements.
- 2) Test alarm set points of the carbon monoxide monitoring system with calibration gases and verify sequence of operation.
- 3) Prepare a written report to record test procedures, test results and corrective actions if required.
- 4) Report should also cover the requirements for accessories like adequacy of alarm types, signs and protective equipment.
- 5) Repair or replacement of malfunctioning units should be performed at the manufacturer's factory.

Step 19: Demonstration and Training

Utilize a factory-authorized service representative to train owner's maintenance personnel to adjust, operate, trouble shoot, calibrate and maintain the carbon monoxide monitoring system.

Step 20: Calibration

- 1) Calibration intervals must comply with manufacturer's recommendations.
- 2) Calibration kits should be provided at the date of delivery of the gas detection system.
- 3) Owner may consider using factory-authorized service representative to maintain and calibrate the gas monitoring system periodically.

Energy Savings Analysis

Step 21: Energy saving calculations – electrical fan motors

The capital and operating cost of a carbon monoxide monitoring system versus the energy and maintenance of running the ventilation at higher volumes can be an important decision factor.

Time of Day Fan Scheduling

Some manufacturers are offering a time switch in their CO monitoring system or some designs are actuating the ventilation system based on the time of the day even if the garage is equipped with a CO monitoring system.

- The CO monitoring system is detecting the presence of CO and is actuating ONLY when needed
- Many of the benefits of a CO monitoring system are defeated by over-riding it with a time switch.

Diesel Exhaust Monitoring

Nitrogen dioxide (NO₂) is the major contaminant to be considered in the design of a ventilation system when diesel-powered vehicles will be present.

- Detection of nitrogen dioxide is done where a significant quantity of diesel engines typically are located such as train stations, bus and truck maintenance garages, rapid transit authorities, car dealerships, ambulance bays, loading docks and diesel-powered vehicle parking structures.



Honeywell Analytics Lines of Business



Commercial

Gas detection from standalone units to fully engineered, multi-point systems, all offering cost-effective regulatory compliance

- » Applications: parking structures, chillers, mechanical rooms, office towers, commercial buildings, shopping centers, swimming pools, golf courses, schools and universities, laboratories

Industrial

Renowned Sieger and Manning gas detection systems with advanced electrochemical, infrared and open path sensing technologies

- » Applications: oil and gas, cold storage, water/wastewater treatment, chemicals, engine rooms, plastics and fibers, agriculture, printing and light industrial

Portables

Single or multi-gas Lumidor and other premium detectors with compact, lightweight designs ranging from simple alarm only units to advanced, fully configurable and serviceable instruments

- » Applications: underground utility and electricity ducts, boiler rooms, post-fire sites, sewers, industrial plants, industrial hygiene, first responder teams, remote fleets



Find out more

www.honeywellanalytics.com

Contact Honeywell Analytics:

Honeywell Analytics Inc.
4005 Matte Blvd., Unit G
Brossard, QC, Canada
J4Y 2P4

Tel: +1 450 619 2450

Toll free: +1 800 563 2967

Fax: +1 888 967 9938

Technical Services

ha.service@honeywell.com

www.honeywell.com

High Tech/Government

A complete portfolio of gas and chemical detection instrumentation including infrared spectroscopy (MST) with no cross interference, to Chemcassette paper-based solutions (MDA Scientific) offering detection down to parts per billion

- » Applications: semiconductor manufacturing and nanotechnology, aerospace propulsion and safety, specialty chemicals industry, research laboratories, emergency response

Technical Services

24/7 global network includes post-sales service and Systems Integration teams

- » Emergency call out, service contracts, on/off-site repair, training and commissioning
- » Complete range of spares, consumables and accessories

Please Note:

While every effort has been made to ensure accuracy in this publication, no responsibility can be accepted for errors or omissions. Data may change, as well as legislation, and you are strongly advised to obtain copies of the most recently issued regulations, standards, and guidelines. This publication is not intended to form the basis of a contract.