

Product Overview

XNX

Honeywell

Introducing... X (inputs) 'n' X (outputs)

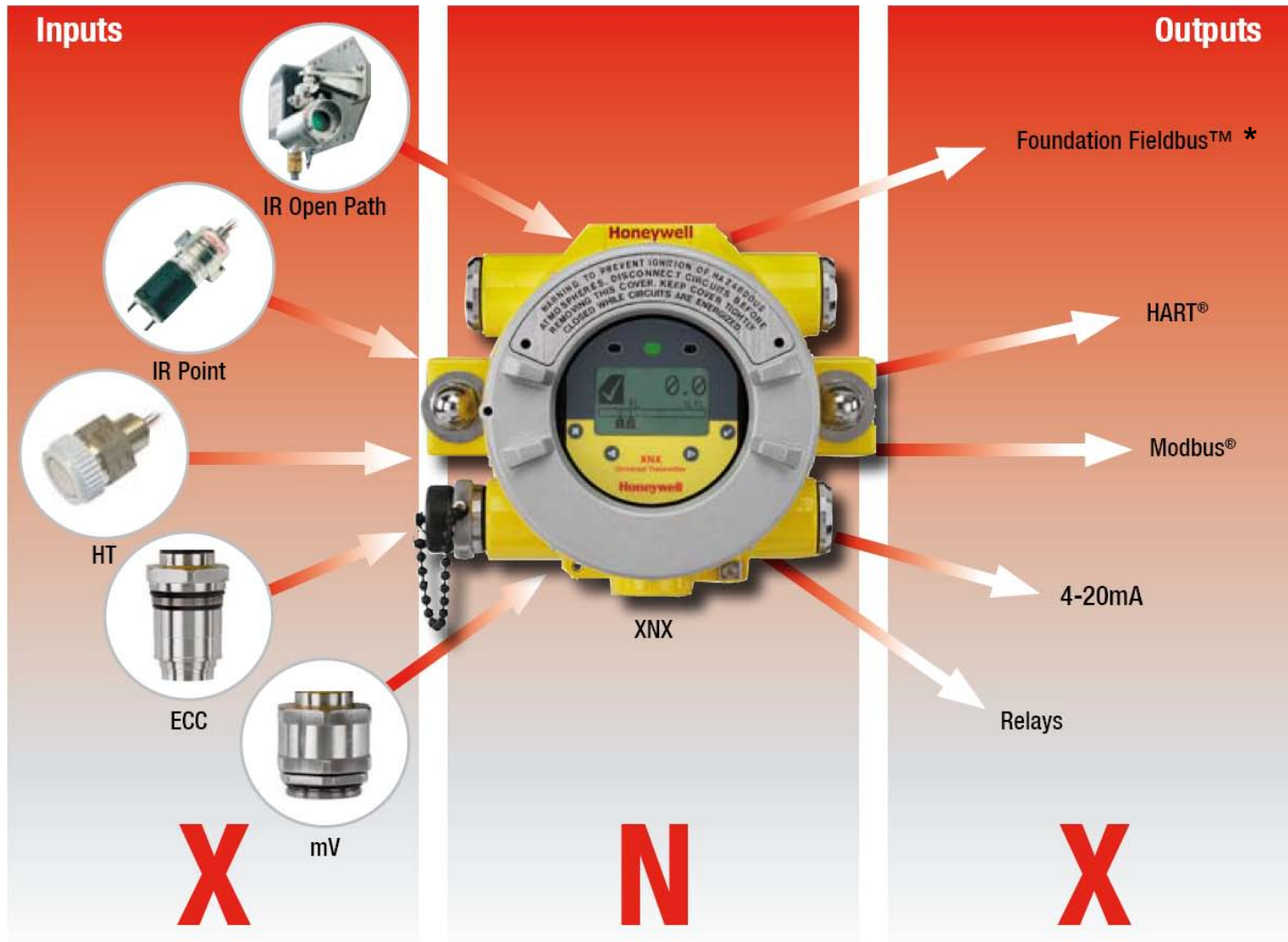

*Pending

XNX Product Overview



- A 3 or 4 wire sink, source or isolated 4-20mA output with HART® universal transmitter
- For use with all Honeywell Analytics gas detection technologies (catalytic, EC and IR)
- Compliant with the latest certification standards
- New range of XNX EC toxic and flammable catalytic and IR MPD sensors
- Common transmitter for all sensors
- HART® over 4-20mA as standard
- Optional relays, local HART® port, Modbus® or Foundation Fieldbus™ (pending) outputs

- **Compatible with full range of HA sensor technologies**

- Catalytic, Infrared and EC Sensors

- **New Multi Purpose Detector (MPD)**

- Smart sensor with plug in catalytic and IR cartridges
- Serviceable Stainless steel sensor housing
- Catalytic: Flammable gases in the range 0-100%LEL
- IR: Hydrocarbon gases in the range 0-100%LEL (0-5%Vol) and CO2 0-5%Vol



- **New XNX EC Sensor**

- Smart sensor with plug in toxic and oxygen sensor cartridges
- Serviceable Stainless steel sensor
- Intrinsically Safe sensor socket allowing 'hot swap' without the need for a hot work permit.



- **Compatible with existing HA sensors**

- Sensepoint (and 705) High Temperature and PPM (0-10%LEL or 10,000ppm)
- Searchpoint Optima and Searchline Excel



Reflex™ Detection Cell Diagnostics

- Reflex™ is a Honeywell Analytics patented fault diagnostic routine for electrochemical cells
- Reflex™ increases operator confidence of detector operability and availability
- Reflex™ is initiated automatically by the transmitter
 - On power up
 - Sensor exchange
 - At 8 hourly intervals during operation
- Reflex™ checks for:
 - Cell presence
 - Cell dry out
 - Cell open circuit and cell short circuit
 - (Note: Not relevant for O₂ detection. Does not remove the need for regular response gas checks or calibration).



Configuration to Customer Requirements

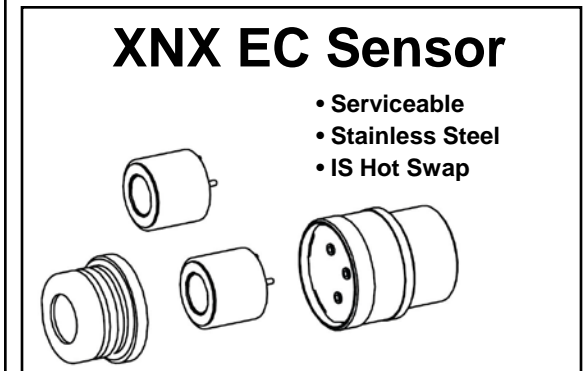
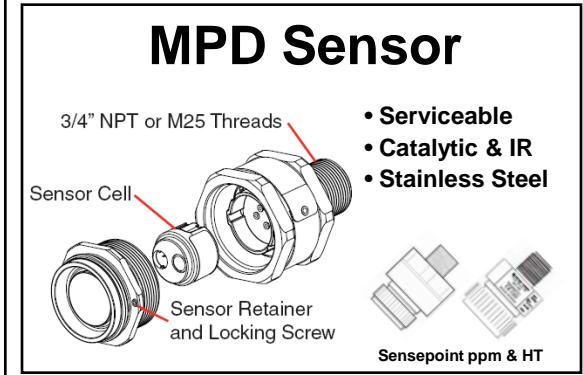
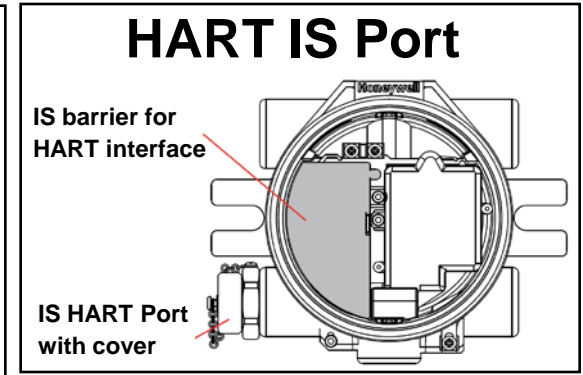
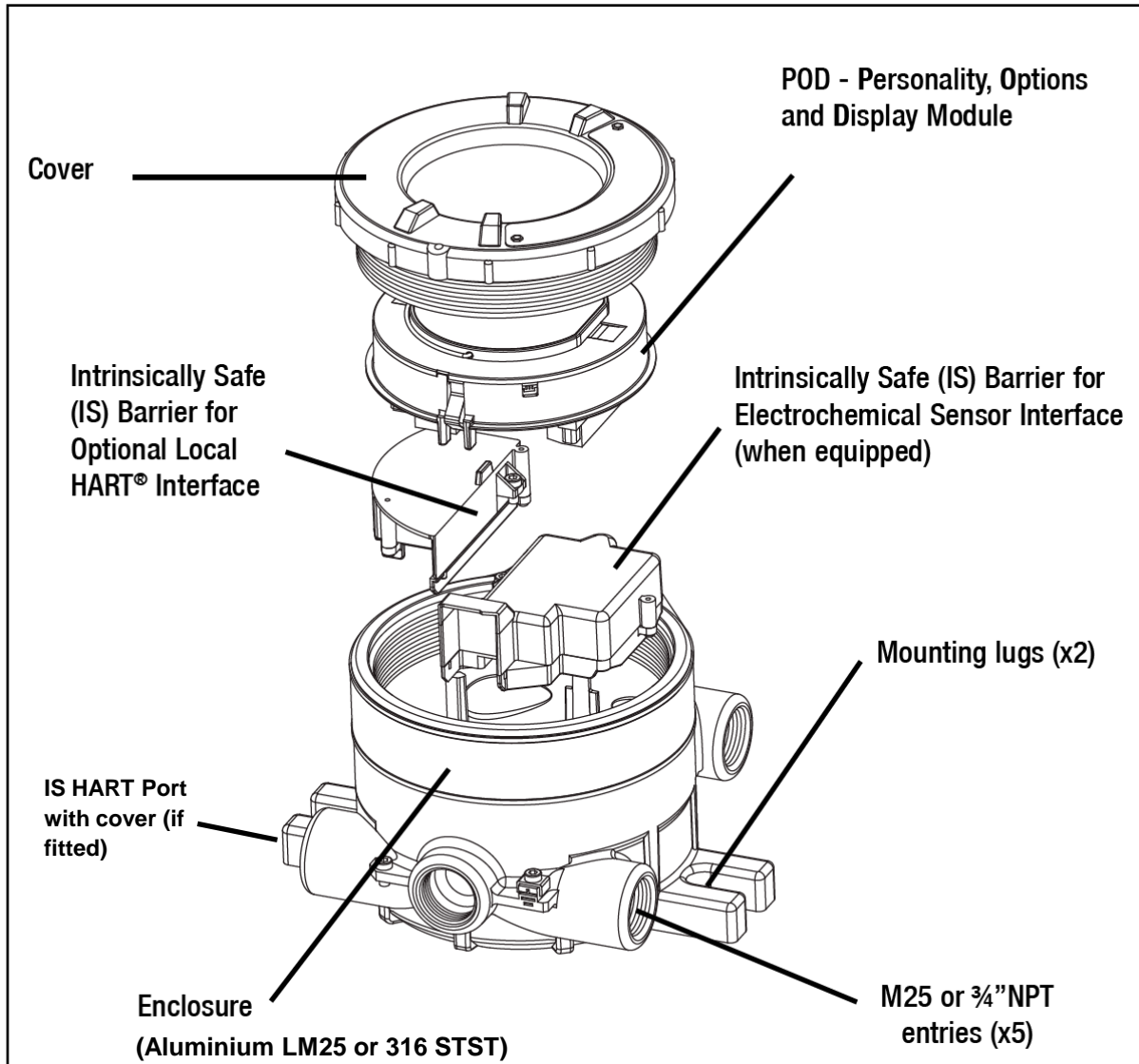

POD- Provides the Flexibility

- XNX has three basic PODs:
 - The mV (Millivolt) personality (CB/IR Slug)
 - ◆ MPD, Sensepoint HT, PPM and Model 705 HT
 - The EC (Electrochemical cell) personality
 - ◆ New IS XNX EC toxic and Oxygen sensors
 - The IR (Infrared) personality (Optima/Excel)
 - ◆ Searchline Excel and Searchpoint Optima Plus
- **Mutually exclusive options for each POD**
 - Relays, Modbus® or Foundation Fieldbus™*

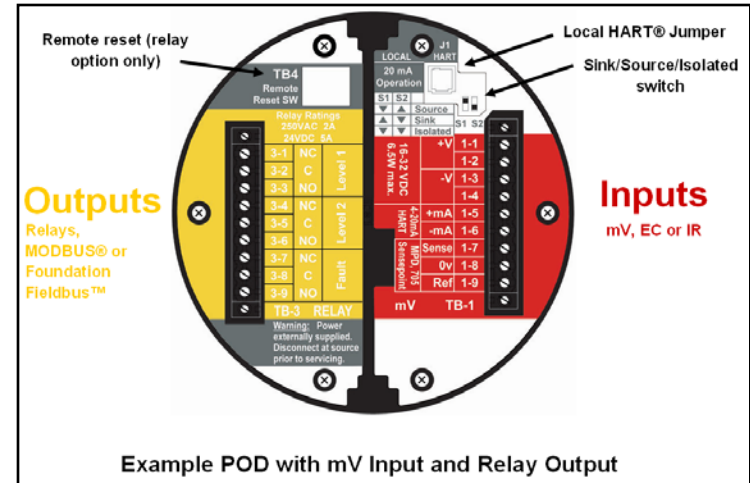

Personality	XNX mV					XNX EC	XNX IR	
Sensors Supported	MPD Flammable Catalytic	MPD Flammable Infrared (Flam and CO ₂)	Sensepoint HT (High Temperature)	Sensepoint PPM	705 HT (High Temperature)	XNX Toxic and Oxygen Sensors	Searchpoint Optima	Searchline Excel
Product Image								

* Pending

Simple installation

Installation Options:

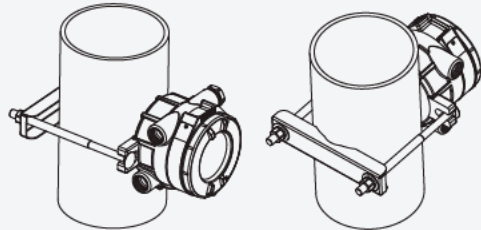

Vertical or Horizontal Pipe Mounted
(Using Optional Pipe Mounting Bracket)

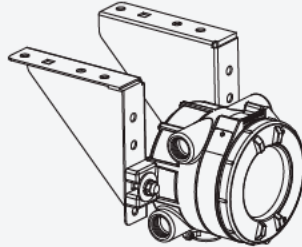

Ceiling Mount

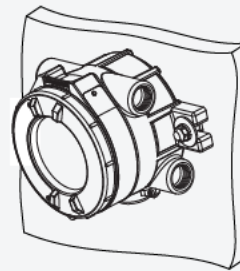

Surface Mounted

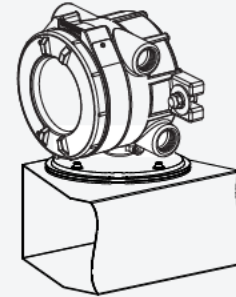

Duct Mounted

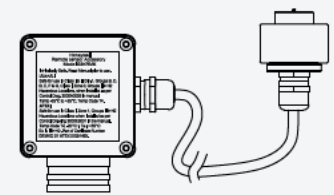

Optional remote sensor
mounting kit for XNX EC
sensor

Wiring Schematics

The XNX transmitter may be configured Current Source, Sink or Isolated. These options are offered to allow greater flexibility in the type of control system that it can be used with. Source/Sink/Isolated is selectable via the switch located on the back side of the POD.

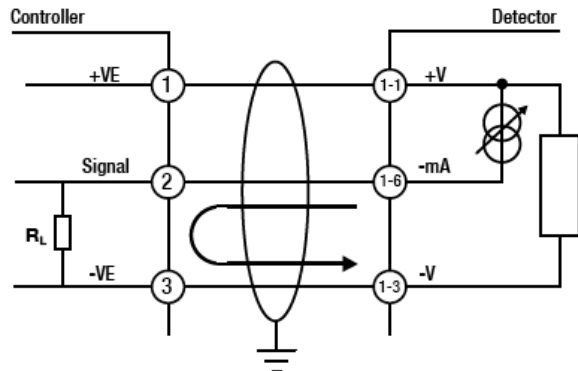

XNX Source Configuration

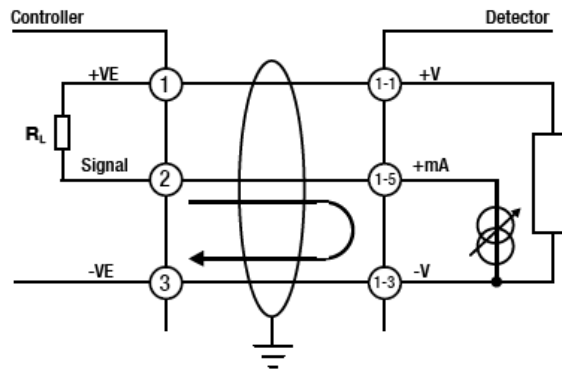

XNX Sink Configuration

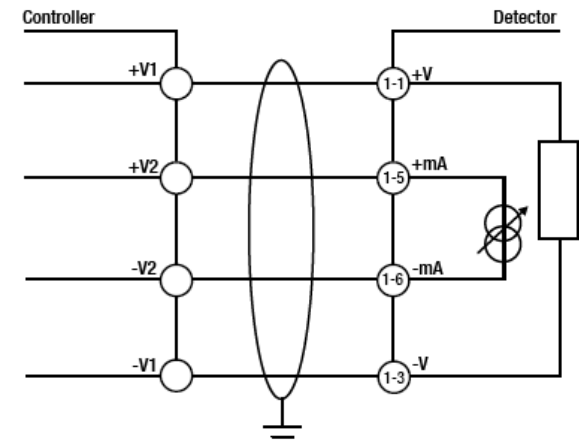

XNX Isolated Configuration

Note: Terminate cable screen at the detector or the controller, not both.

- **Materials**

- **Painted Aluminium LM25**
 - ◆ General Industrial applications
- **Painted Stainless Steel 316**
 - ◆ Offshore and harsh environments
 - ◆ Food and beverage markets

- **Hazardous area certified**

- ATEX, IECEx, UL and cUL

- **Mounting**

- 2 x Integral mounting lugs
- Suitable for M10-12 bolts
- Optional Pipe, Ceiling or Duct mounting options (see following slides)

- **Dimensions**

- See separate drawings for individual XNX & various sensor option combinations

- **Entries**

- 5 x M25 (ATEX/IECEX version)
- 5 x ¾" NPT (UL/CSA versions)
- **Suitable blanking plugs also supplied**
 - ◆ Must be suitably sealed to maintain IP rating

Outline transmitter dimensions:

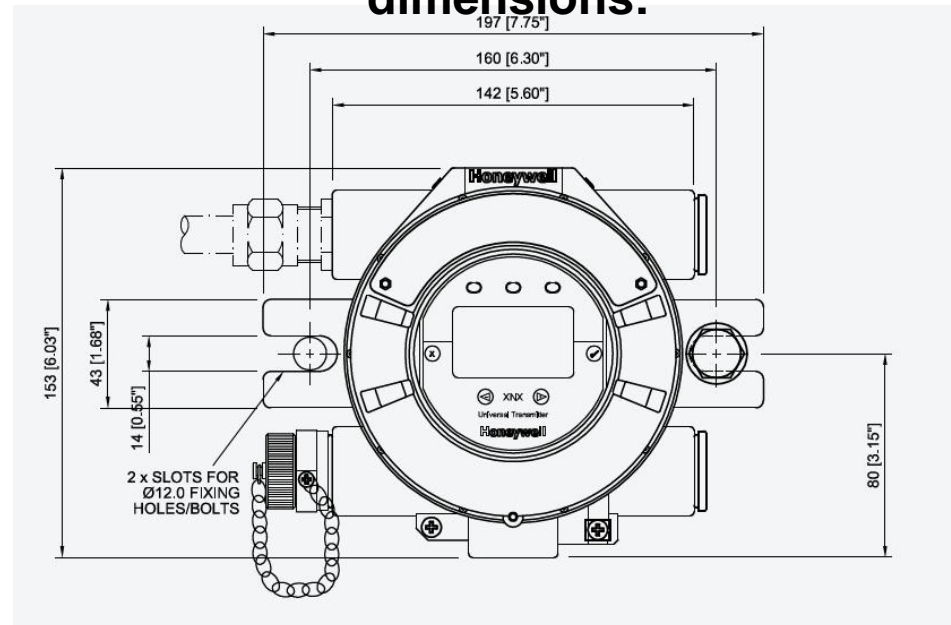

XNX Mechanical Data

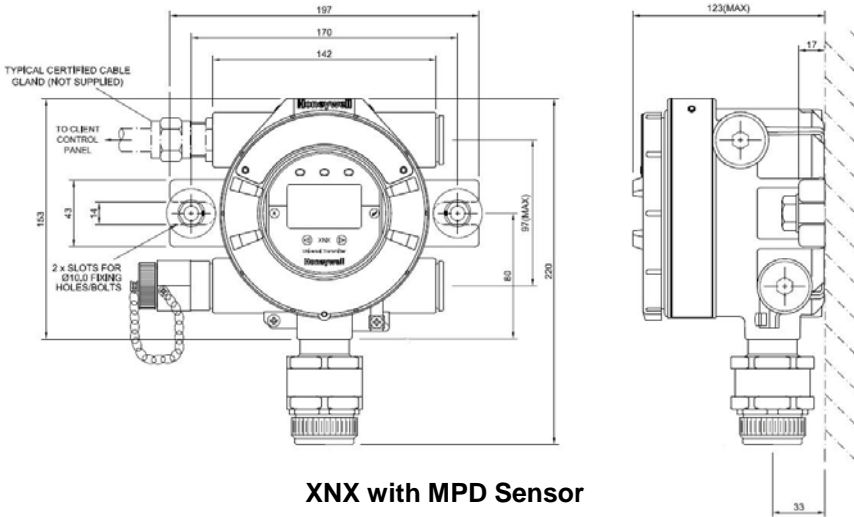

XNX with MPD Sensor

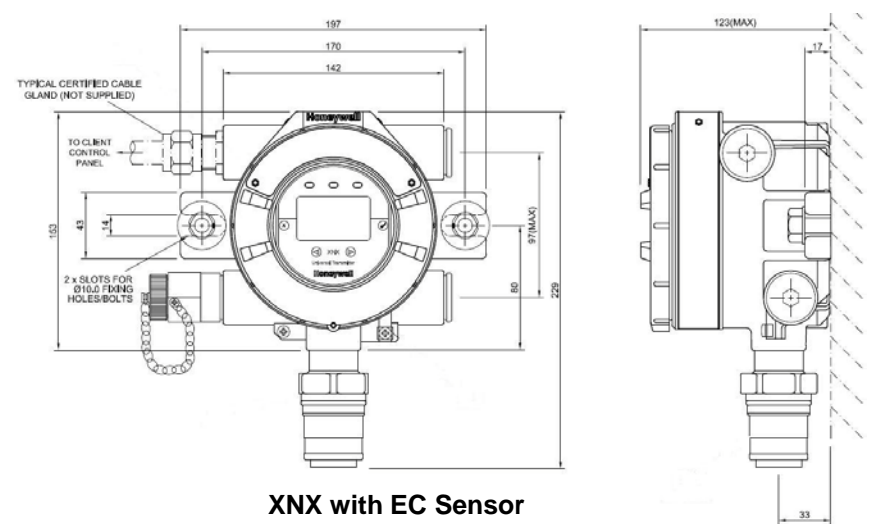

XNX with EC Sensor

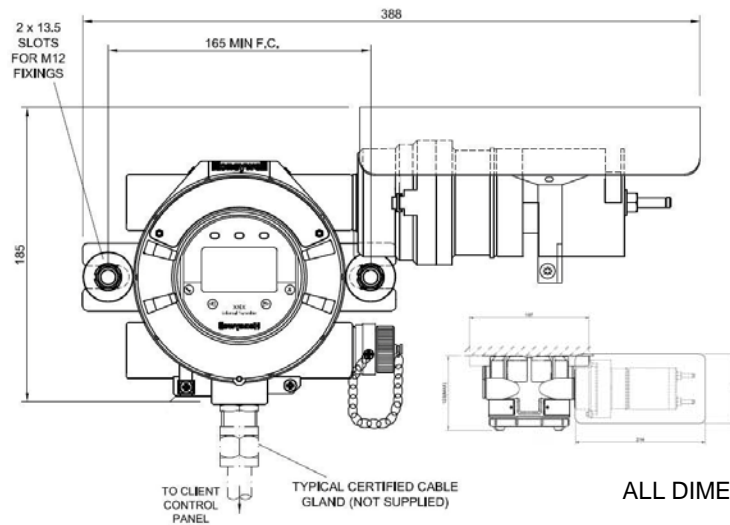

XNX with Optima Plus Sensor

ALL DIMENSIONS IN mm. 1" = 25.4mm

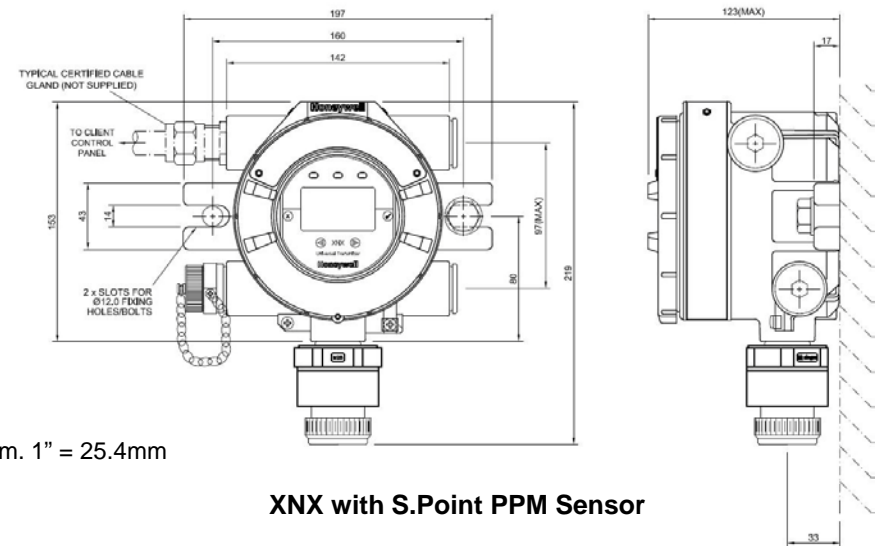

XNX with S.Point PPM Sensor

XNX Mechanical Data

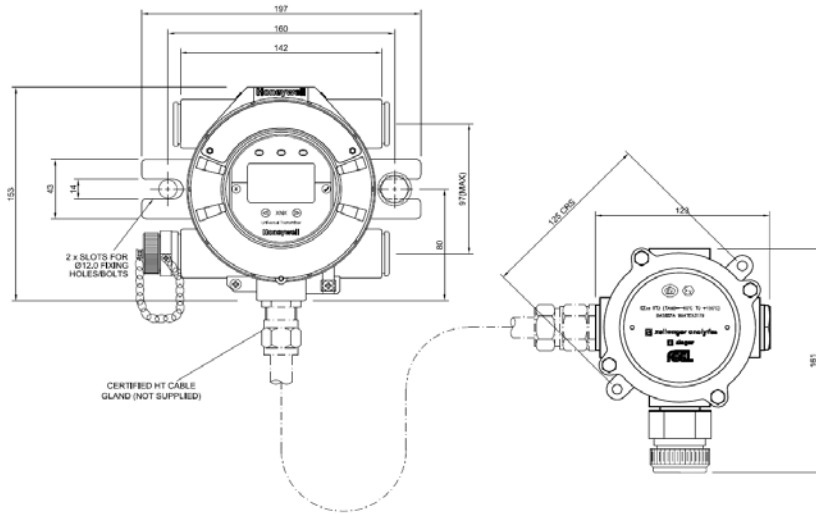

XNX with Remote Sensepoint HT

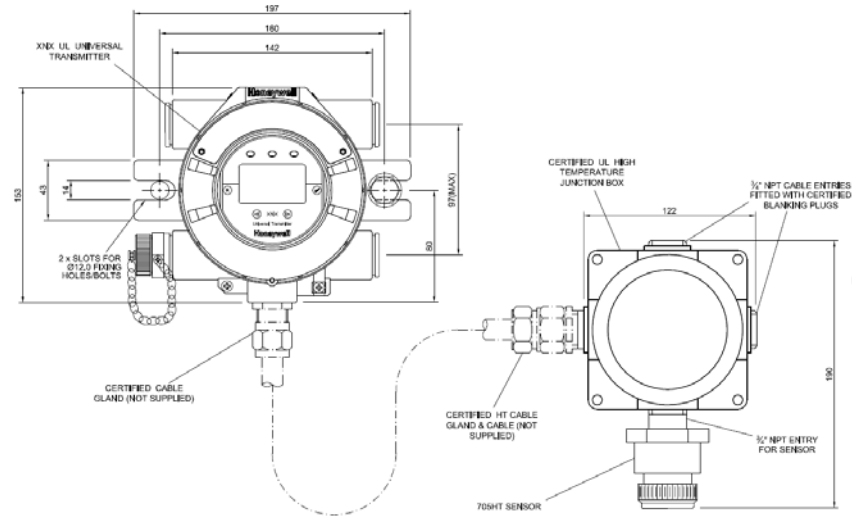

XNX with Remote 705HT

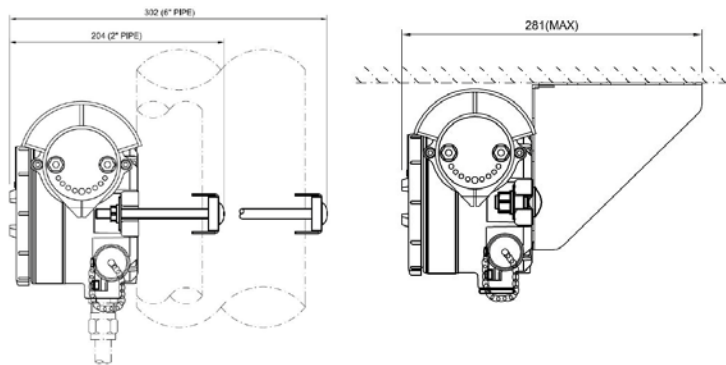

XNX with Optima Plus Pole & Ceiling Mount

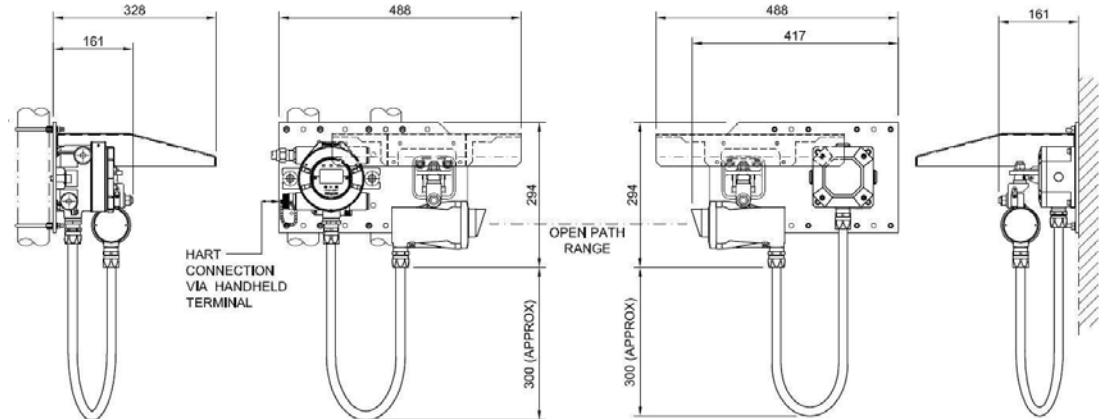

EXCEL RECEIVER ASSEMBLY
(INC. DETAILS FOR 2" N.B PIPE
MOUNT APPLICATIONS)

XNX with Searchline Excel

EXCEL TRANSMITTER ASSEMBLY
INCLUDING DETAILS FOR SURFACE
MOUNTS, APPLICABLE TO
TRANSMITTERS AND RECEIVERS)

ALL DIMENSIONS IN mm. 1" = 25.4mm

Simple non intrusive operation

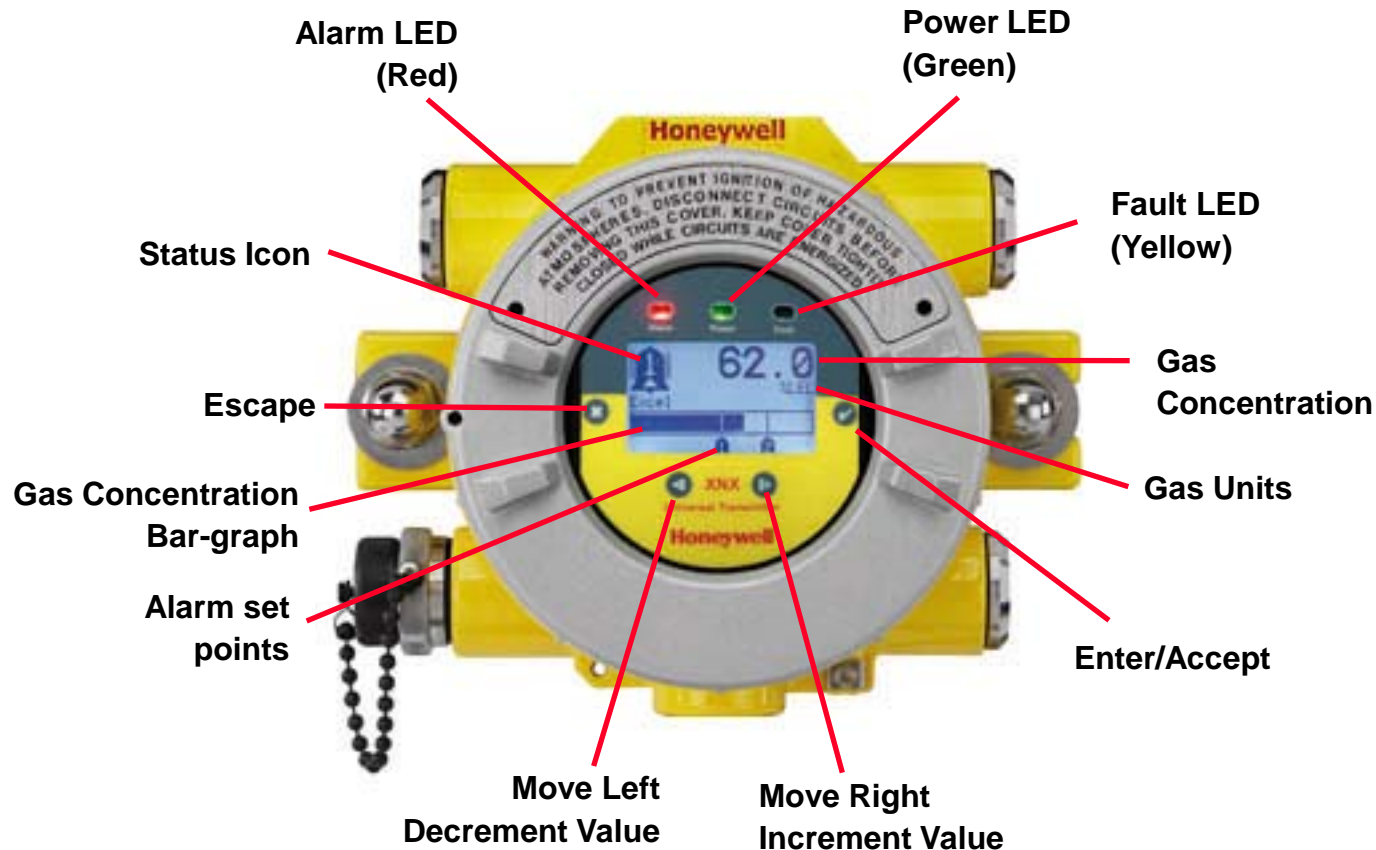

- Bright powder blue backlit LCD (auto dimming)
- Multilingual text, symbols and icons

- Simple Magnetic switch operation
- Optional local HART® handheld interface

XNX Universal Transmitter Summary

- **Reduced installation costs**
 - **Common design for all Detectors**
 - ◆ Same tools/installation methods reduces install costs
- **Reduced operation costs**
 - **Same user interface for all detectors**
 - ◆ Less chance of incorrectly configuring/interpreting readings/messages increases detector up time
 - ◆ Reduced training time reduces training costs
- **Reduced maintenance costs**
 - **Replaceable plug in sensors (MPD & EC)**
 - ◆ Less time and cost to maintain detectors
 - ◆ IS 'hot swap' EC sensor
 - **Many common spare parts**
 - ◆ Reduced maintenance/spares stock level and cost



XNX Universal Transmitter Summary

- **Increased safety**

- **Compatible with all Honeywell Analytics gas sensors**

- ◆ Allows selection of best sensor technology for each application

- **Easy to integrate**

- **Ability to change configuration as site needs change**

- ◆ Choose what's best for your application
- ◆ 4-20mA and HART® as standard
- ◆ Optional relays, Modbus®, local IS HART® port, Foundation Fieldbus™(pending)
- ◆ Start with 4-20mA, then upgrade to Foundation Fieldbus™ when site standard changes

- **Future-proofed for new output standards**

- ◆ Hooks for new protocols as they are developed

