

- Operating temperature range: -55°C to +80°C (see certification).
- Operating humidity range: 20% to 90% RH continuous. 10% to 99% RH intermittent - non condensing.
- Operating pressure range: 90 to 110 k Pa.
- Warm up time: no greater than 10 minutes.
- Voltage range: 2.9 V to 3.5 V bridge (at 200mA).
- Power consumption: 700mW.
- Signal output: mV bridge.
- Calibration flow rate: recommended between 1 and 1.5 l/min.
- Poisoning: the sensing elements may become inactive after extensive exposure to silicones, halogenated hydrocarbons, heavy metals or sulphur compounds.
- Expected operating life: 5 years.
- IP rating: IP65 standard; IP66/67 with weather protection.
- Certification:
  - Ex II 2G EExd IIC T6 -55 to +55°C.
  - Ex II 2G EExd IIC T5 -55 to +70°C.
  - Ex II 2G EExd IIC T4 -55 to +80°C.
  - BAS98ATEX2156X.
  - UL approved via IEC 79 (pending).

This product complies with the relevant CE standards concerning performance: EMC to BS EN50081 parts 1 & 2, BS EN50082 parts 1 & 2 and EN 50054.

- Explosive gas atmosphere:** a mixture in air of combustible materials in the form of gas vapour or mist in which, after ignition, combustion spreads throughout the unconsumed mixture.
  - Lower explosive limit (LEL):** the volume of combustible gas or vapour in air below which an explosive gas atmosphere will not be formed.
  - Exd:** flame proof or explosion proof within the confines of European standards EN50014 and EN50018. An enclosure that can withstand the pressure developed during the internal explosion of an explosive mixture and which prevents transmission of the explosion to the explosive atmosphere surrounding the enclosure.
  - Exe:** increased safety within the confines of European standards EN50014 and EN50019 applied to electrical apparatus that does not produce arcs or sparks in normal service, in which additional measures are applied so as to give increased security against the possibility of excessive temperatures.
  - PPS:** polymer polyphenylene sulphide, suitable for use in most chemical environments (eg acids, aldehydes, ketones, alkalies, petroleum, aromatic hydrocarbons, alcohols, ethers, esters and most chlorinated hydrocarbons). Avoid immersion in solvents for extended periods. For further details contact Zellweger Analytics Ltd.
- Certification label as defined in directive 94/9/EC**
- |  |  |  |   |
|--|--|--|---|
| CE mark - conforms to all applicable European directives | manufacturer's trademark & address<br>zellweger analytics<br>Poole Dorset<br>SensePoint<br>static risk - read manual | certification number<br>(Bas98ATEX2156X) | explosion protection mark and equipment group & category<br>(II 2G)   |
| ident.number of ATEX notified body<br>0600               | product name<br>SensePoint   | test house trademark<br>Bas98ATEX2156X   | certification code as EN50014 1992<br>EEx d IIC T6 Tamb -55 +55°C<br>EEx d IIC T5 Tamb -55 +70°C<br>EEx d IIC T4 Tamb -55 +80°C |
|  | caution  |  | certified ambient temperature range   |

CONTENTS

1.	INTRODUCTION .....	2
2.	ASSOCIATED DOCUMENTATION .....	2
3.	SAFETY .....	3
3.1	Warnings .....	3
3.2	Cautions .....	3
4.	OPERATIONS .....	4
4.1	Installation .....	4
4.2	Calibration .....	5
4.3	Fault finding .....	9
5.	MAINTENANCE .....	10
5.1	Changing filters .....	9
	Appendix A - Specifications .....	11
	Appendix B - Glossary .....	12
	Appendix C - Main features .....	13
	Appendix D - Spare parts .....	14

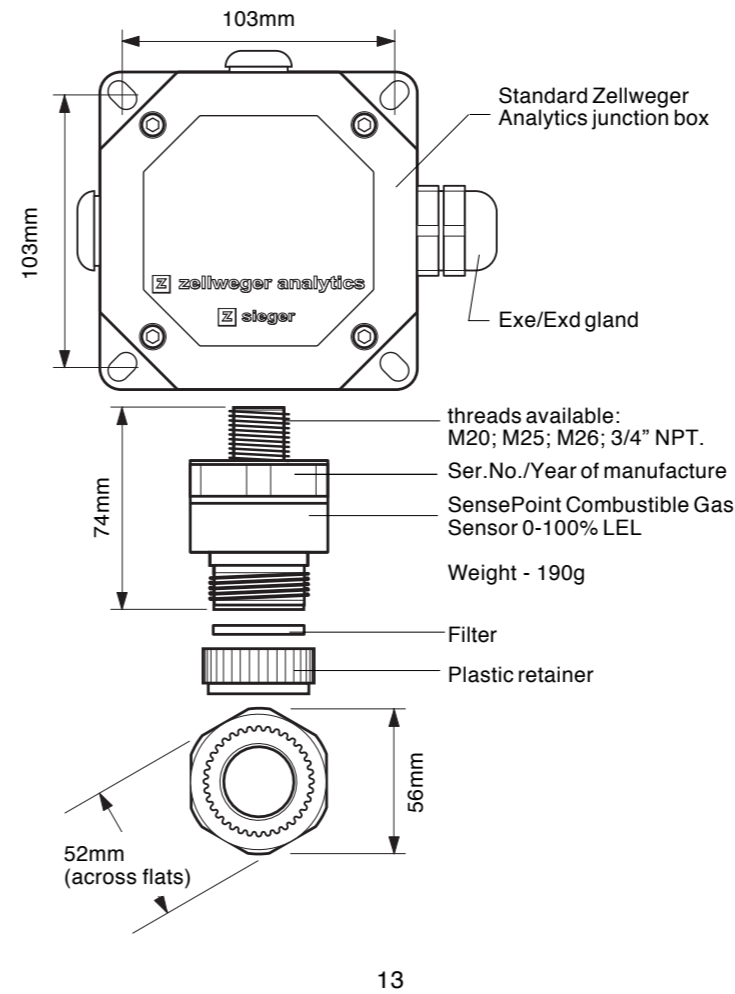

Sensor .....	2106B1200 (M20)
Sensor .....	2106B1201 (M25)
Sensor .....	2106B1202 (M26)
Sensor .....	2106B1204(3/4 NPT)
Weather protection .....	02000-A-1640
Sensor filter .....	00780-F-0018
Flow housing .....	02000-A-1645
Collecting cone .....	02000-A-1642
Junction box (std) .....	00780-A-0100
High temperature junction box .....	555-090-038
High temperature weather protection .....	00780-A-0076

To reorder a complete new sensor, see the label on the product leads, or contact Zellweger Analytics Ltd.

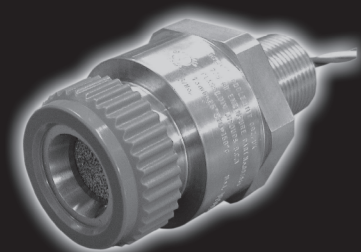

1. INTRODUCTION & 2. ASSOCIATED DOCUMENTATION

- 1. INTRODUCTION**

SensePoint is a sealed disposable sensor for the detection of flammable gases and is designed for use with an approved junction box.

It employs a catalytic pellistor sensor device which is used as part of a bridge measuring circuit.

Sensepoint is certified for hazardous areas to EN50018 and is protected against water and dust ingress to IP66/67.

The sensor is available in M20, M25, M26 or 3/4 NPT thread versions. All accept accessories from the specified range.
- 2. ASSOCIATED DOCUMENTATION**

2106M0502 SensePoint Technical Handbook.

Refer to the relevant control system manual for connection information.

Find out more  
www.honeywellanalytics.com

**Customer business centre Europe and the rest of the world**  
Honeywell Analytics AG  
Wilstrasse 11-U11  
CH-8610 Uster  
Switzerland  
Tel: +41 (0)44 943 4300  
Fax: +41 (0)44 943 4398  
sales@zelana.co.uk

**Customer business center Americas**  
Honeywell Analytics Distribution, Inc.  
400 Sawgrass Corporate Pkwy  
Suite 100  
Sunrise, FL 33325  
USA  
Tel: +1 954 514 2700  
Toll free: +1 800 538 0363  
Fax: +1 954 514 2784  
sales@zelana.com

**Please Note:**  
While every effort has been made to ensure accuracy in this publication, no responsibility can be accepted for errors or omissions. Data may change, as well as legislation, and you are strongly advised to obtain copies of the most recently issued regulations, standards, and guidelines. This publication is not intended to form the basis of a contract.  
© 2005 Honeywell Analytics  
Issue 01 12/2005  
H\_MAN0590\_V1  
2106M0518  
© 2005 Honeywell Analytics





3.1 WARNINGS

- This apparatus is not suitable for use in oxygen enriched atmospheres (>21%V/V). Oxygen deficient atmospheres (<10%V/V) may suppress sensor output.
- Refer to local or national regulations relative to installation at the site.
- Operator should be fully aware of the action to be taken if the gas concentration exceeds an alarm level.
- SensePoint should be protected from mechanical impact. Installation should consider not only the best placing for gas leakage related to potential leak points, gas characteristics and ventilation, but also where the potential of mechanical damage is minimized or avoided.

3.2 CAUTIONS

- Atmospheres above 100% LEL may suppress the sensor reading.
- Do not modify or alter the sensor construction as essential safety requirements may be invalidated.
- Install using certified Exe or Exd junction box, connectors and glanding.
- Dispose of in accordance with local disposal regulations. Materials used -Fortron® (PPS- Polyphenylene Sulphide).

4.1 INSTALLATION

The SensePoint must be fitted into a suitably approved Exe or Exd junction box fitted with a suitably approved cable gland. This should be correctly installed before use. Cabling should be multicore, three wire minimum, of conductor size 2.5 mm<sup>2</sup> max.

The sensor should be fitted into a threaded hole within the junction box and locked in place with a lock nut. Ensure that junction box thread is compatible with sensor thread.

The sensor should be installed in a location free from direct heat sources. It should be fitted such that it either points downwards or horizontally. It is not recommended that the sensor points upwards. See the technical handbook for installation in forced air conditions.

Wiring connections are:-

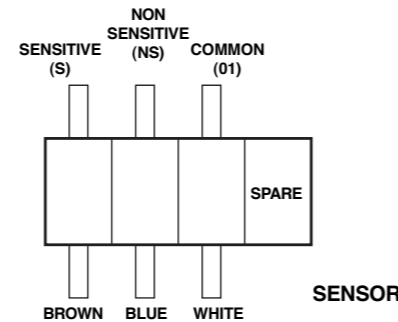

The unit requires 200mA current with a nominal 3V supply. Installation and service are to be performed by a qualified installation engineer with the power to the sensor disconnected.

4.2 CALIBRATION

Prior to calibration, allow the sensor to warm up for approximately 10 minutes. Re-calibration should only be attempted by qualified service personnel.

First zero the control system with no gas present on the sensor. If combustible gas is suspected to be in the vicinity of SensePoint, flow clean air over the sensor using a flow housing (see below).

Fit a flow housing and connect a cylinder of either air, for a zero, or a known concentration of gas in air, at approximately the alarm point (e.g. 50% LEL), to the flow housing. Pass the gas through the flow housing at a flow rate of approximately 1 l to 1.5 l per minute. Allow the sensor to stabilise. When gassing with air, adjust the control card to indicate zero. For span, the control card should be adjusted to indicate the concentration of the target gas being applied. Remove the flow housing and the gas supply.

Sensors should be calibrated at concentrations representative of those to be measured. It is always recommended that SensePoint is calibrated with the target gas it is to detect. If this is not possible, then cross calibration can be used.

For calibration in fast flow conditions see the technical handbook.

4.3 CROSS CALIBRATION PROCEDURE

When the SensePoint sensor is to be calibrated with a gas which is different to the gas/vapour to be detected, the following cross calibration procedure should be followed.

Table 1 lists gases according to the reaction they produce at the detector. An eight star (8\*) gas produces the highest output while a one star (1\*) gas produces the lowest output. (These are not applicable at ppm levels.)

To calibrate the SensePoint sensor, obtain the star rating for both the test gas and the gas to be detected from table 1. These values may then be used in table 2 to obtain the required meter setting when a 50% LEL test gas is applied to the detector.

If a sensor is to be used to detect a gas other than that for which it was calibrated, the required correction factor may be obtained from table 3. The meter reading should be multiplied by this number in order to obtain the true gas concentration.

IMPORTANT

- Since combustible sensors require oxygen for correct operation, a mixture of gas in air should be used for calibration purposes.
- Assuming an average sensor performance, the sensitivity information in tables 1 to 3 is normally accurate to ± 20%.

Table 1: Star Rating of Gasses

Gas	Star Rating	Gas	Star Rating
Acetone	4*	Hexane	3*
Ammonia	7*	Hydrogen	6*
Benzene	3*	Methane	6*
Butane	4*	Octane	3*
Diethyl ether	4*	Propan-2-ol	4*
Ethane	6*	Propane	5*
Ethanol	5*	Styrene	2*
Ethyl acetate	3*	Tetra hydrofuran	4*
Ethylene	5*	Xylene	2*

Table 2: Meter Settings

* Calibration Gas	* Rating of Gas to be Detected							
	8*	7*	6*	5*	4*	3*	2*	1*
8*	50	62	76	95	-	-	-	-
7*	40	50	61	76	96	-	-	-
6*	33	41	50	62	78	98	-	-
5*	26	33	40	50	63	79	100	-
4*	21	26	32	40	50	63	80	-
3*	-	21	26	32	40	50	64	81
2*	-	-	-	25	31	39	50	64
1*	-	-	-	-	25	31	39	50

Note: These settings must only be used with a calibration gas concentration of 50% LEL.

Cross Calibration example:

- The target gas to be detected is Butane. The calibration gas available is Methane (50% LEL).
- Look up the star rating for each gas (Table 1): Butane 4\*, Methane 6\*
- Check the meter settings for 50% LEL calibration gas (Table 2).
- The control card meter should therefore be set to 78% to give an accurate reading for Butane, using 50% LEL Methane as a calibration gas.

Table 3: Meter Multiplication Factors

Unit calibrated To Detect	Unit used to detect							
	8*	7*	6*	5*	4*	3*	2*	1*
8*	1.00	1.24	1.52	1.89	2.37	2.98	3.78	4.83
7*	0.81	1.00	1.23	1.53	1.92	2.40	3.05	3.90
6*	0.66	0.81	1.00	1.24	1.56	1.96	2.49	3.17
5*	0.53	0.66	0.80	1.00	1.25	1.58	2.00	2.55
4*	0.42	0.52	0.64	0.80	1.00	1.26	1.60	2.03
3*	0.34	0.42	0.51	0.64	0.80	1.00	1.27	1.62
2*	0.26	0.33	0.40	0.50	0.63	0.79	1.00	1.28
1*	0.21	0.26	0.32	0.39	0.49	0.62	0.78	1.00

4.3 FAULT FINDING

Sensor reads non zero all the time:

- gas could be present, ensure there is no combustible gas in the atmosphere.

Sensor reads non zero when no gas is present:

- adjust the zero of the control system.

Sensor reads low when gas is applied:

- adjust the span of the control system.

Sensor reads high when gas is applied:

- adjust the span of the control system.

Sensor reads zero when gas is applied:

- check the wiring.
- check that the dust protection cap has been removed.
- check that the sinter is not obstructed.
- replace the sensor if poisoning is suspected.

5.1 CHANGING FILTERS

- Remove the grey plastic retainer or accessory.
- Remove the old filter and replace with a fresh filter.
- Replace the grey plastic retainer or accessory.

