

Training Presentation

Sensepoint XCD

Honeywell

Industrial Gas Detection

- There are many different applications for flammable, toxic and Oxygen gas detection.
- Industrial processes increasingly involve the use and manufacture of highly dangerous substances, particularly toxic and combustible gases.
- Inevitably, occasional escapes of gas occur, which create a potential hazard to the industrial plant, its employees and people living nearby.
- Worldwide incidents involving asphyxiation, explosions and loss of life, are a constant reminder of this problem.



Industrial Gas Detection Applications

Honeywell



Chemical Plants

Probably one of the largest users of gas detection equipment are Chemical Plants. They often use a wide range of both flammable and toxic gases in their manufacturing processes or create them as by-products of the processes.

Typical Applications:

- Raw material storage
- Process areas
- Laboratories
- Pump rows
- Compressor stations
- Loading/unloading areas

Typical Gases:

Flammable:
General Hydrocarbons

Toxic:
Various including Hydrogen Sulphide, Hydrogen Fluoride and Ammonia

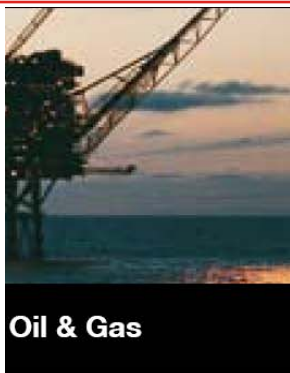

Oil & Gas

The oil and gas industry covers a large number of upstream activities from the on and offshore exploration and production of oil and gas to its transportation, storage and refining. The large amount of highly flammable Hydrocarbon gases involved are a serious explosive risk and additionally toxic gases such as Hydrogen Sulphide are often present.

Typical Applications:

- Exploration drilling rigs
- Production platforms
- Onshore oil and gas terminals
- Refineries

Typical Gases:

Flammable:
Hydrocarbon gases

Toxic:
Hydrogen Sulphide, Carbon Monoxide



Power Stations

Traditionally coal and oil have been used as the main fuel for Power Stations.

In Europe and the US most are being converted to natural gas.

Typical Applications:

- Around the boiler pipework and burners
- In and around turbine packages
- In coal silos and conveyor belts in older coal/oilfired stations

Typical Gases:

Flammable:
Natural Gas, Hydrogen

Toxic:
Carbon Monoxide, SO_x, NO_x and Oxygen deficiency

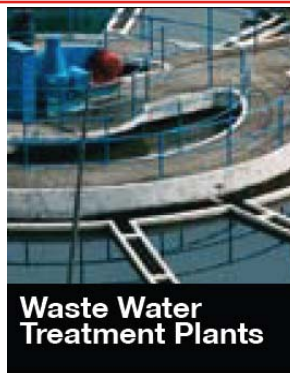

Waste Water Treatment Plants

Waste Water Treatment Plants are a familiar site around many cities and towns.

Sewage naturally gives off both Methane and H₂S. The 'rotten eggs' smell of H₂S can often be noticed as the nose can detect it at less than 0.1ppm.

Typical Applications:

- Digesters
- Plant sumps
- H₂S scrubbers
- Pumps

Typical Gases:

Flammable:
Methane, Solvent vapours

Toxic:
Hydrogen Sulphide, Carbon Dioxide, Chlorine, Sulphur Dioxide, Ozone



Boiler Rooms

Boiler Rooms come in all shapes and sizes. Small buildings may have a single boiler whereas larger buildings often have large boiler rooms housing several large boilers.

Typical Applications:

- Flammable gas leaks from the incoming gas main
- Leaks from the boiler and surrounding gas piping
- Carbon Monoxide given off badly maintained boiler

Typical Gases:

Flammable:
Methane

Toxic:
Carbon Monoxide



Hospitals

Hospitals may use many different flammable and toxic substances, particularly in their laboratories. Additionally, many are very large and have onsite utility supplies and back up power stations.

Typical Applications:

- Laboratories
- Refrigeration plants
- Boiler rooms

Typical Gases:

Flammable:
Methane, Hydrogen

Toxic:
Carbon Monoxide, Chlorine, Ammonia, Ethylene Oxide and Oxygen deficiency

Location of Detectors

- Detectors should be mounted where the gas is most likely to be present.
- Locations requiring the most protection in an industrial plant would be around gas boilers, compressors, pressurised storage tanks, cylinders or pipelines.
- Areas where leaks are most likely to occur are valves, gauges, flanges, T-joints, filling or draining connections etc.



Sensor Location Considerations

- To detect gases that are lighter than air (e.g. Methane and Ammonia), detectors should be mounted at high level and preferably use a collecting cone
- To detect heavier than air gases (e.g. Butane and Sulphur Dioxide), detectors should be mounted at a low level
- Consider how escaping gas may behave due to natural or forced air currents. Mount detectors in ventilation ducts if appropriate
- When locating detectors consider the possible damage caused by natural events e.g. rain or flooding. For detectors mounted outdoors it is preferable to use the weather protection assembly
- Use a detector sunshade if locating a detector in a hot climate and in direct sun
- Consider the process conditions. Butane and Ammonia, for instance are normally heavier than air, but if released from a process line that is at an elevated temperature and/or under pressure, the gas may rise rather than fall
- Detectors should be positioned a little way back from high pressure parts to allow gas clouds to form. Otherwise any leak of gas is likely to pass by in a high speed jet and not be detected
- Consider ease of access for functional testing and servicing
- Detectors should be installed at the designated location with the detector pointing downwards (except optima+).
- This ensures that dust or water will not collect on the front of the sensor and stop the gas entering the detector
- When siting open path infrared devices it is important to ensure that there is no permanent obscuration or blocking of the IR beam. Short term blockage from vehicles, site personnel, birds etc can be accommodated
- Ensure the structures that open path devices are mounted to are sturdy and not susceptible to vibration

Detector Installation Options

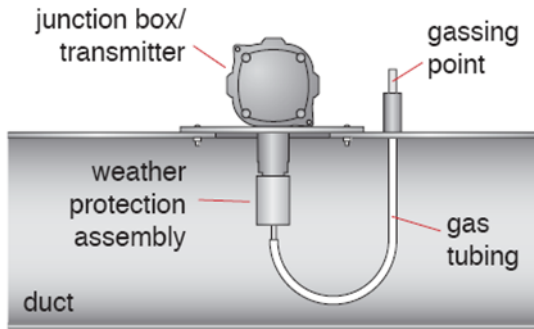

Duct Mounted

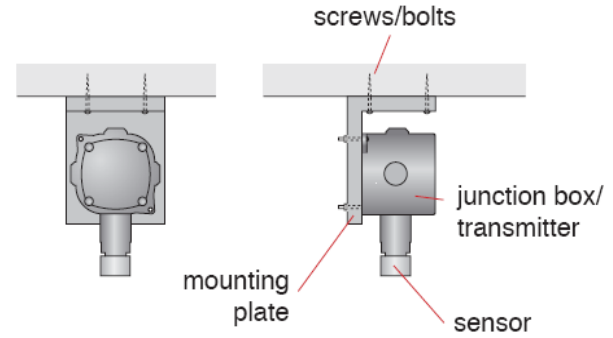

Ceiling Mounted

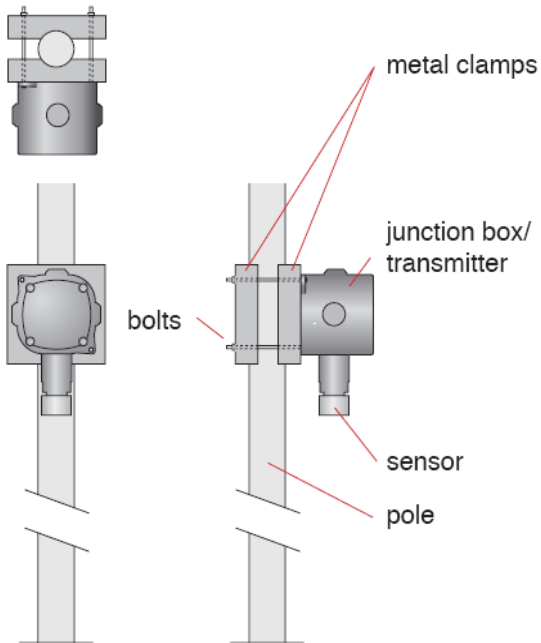

Pipe Mounted

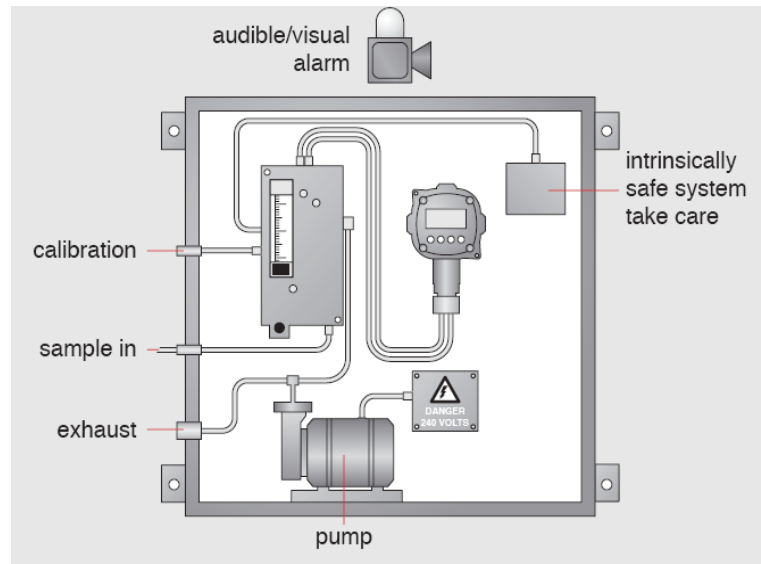

Sampling System

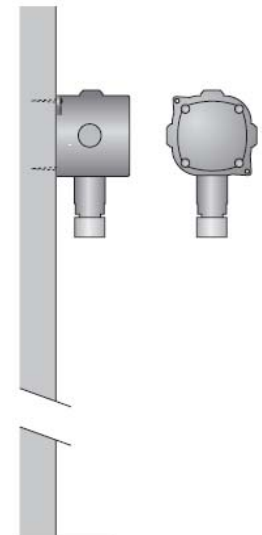

Wall Mounted

Typical System Configurations

REMOTE SENSOR, LOCAL DISPLAY/GASSING

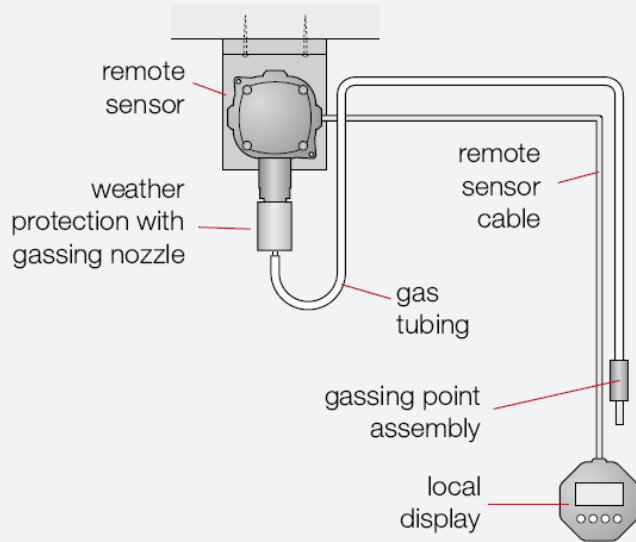

LOCALLY DRIVEN ALARM SYSTEM

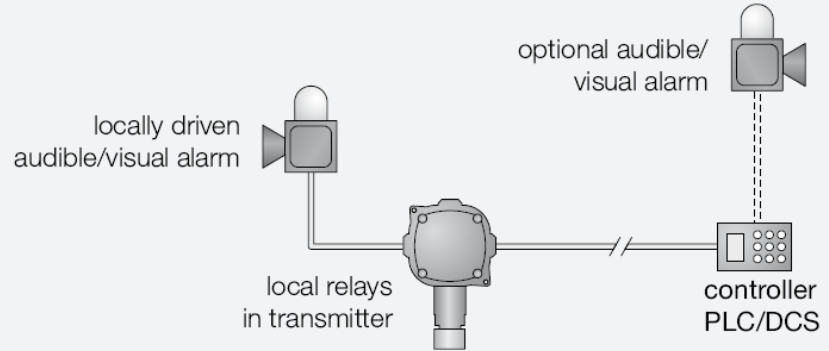

TYPICAL SENSOR/CONTROLLER SYSTEM

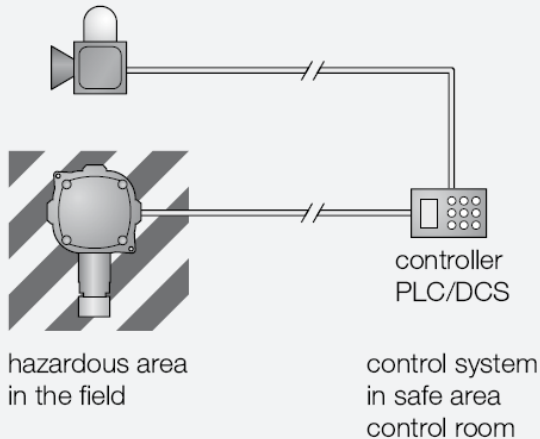



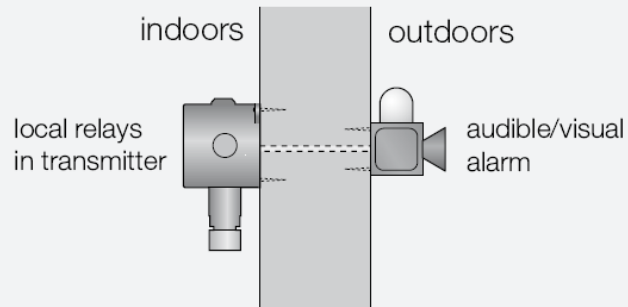

STANDALONE SYSTEM



Example of Small System

Typical small gas detection system protecting a room

Key

-  Gas Detector
-  Audible & Visual Alarm
-  Remote Reset
-  Fused Spur
-  Control Panel

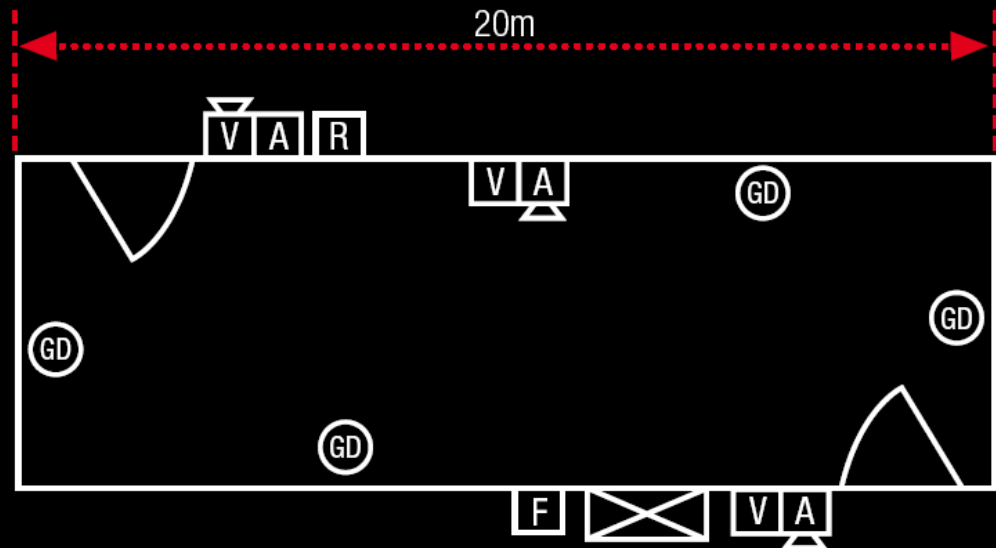

Eg.

- Small Pump Station
- Generator House
- Normally Unmanned

Alarms

- Warning AV prior to entry
- AV internal to evacuate (if occupied)
- Remote reset to silence alarm

Sensepoint XCD Overview

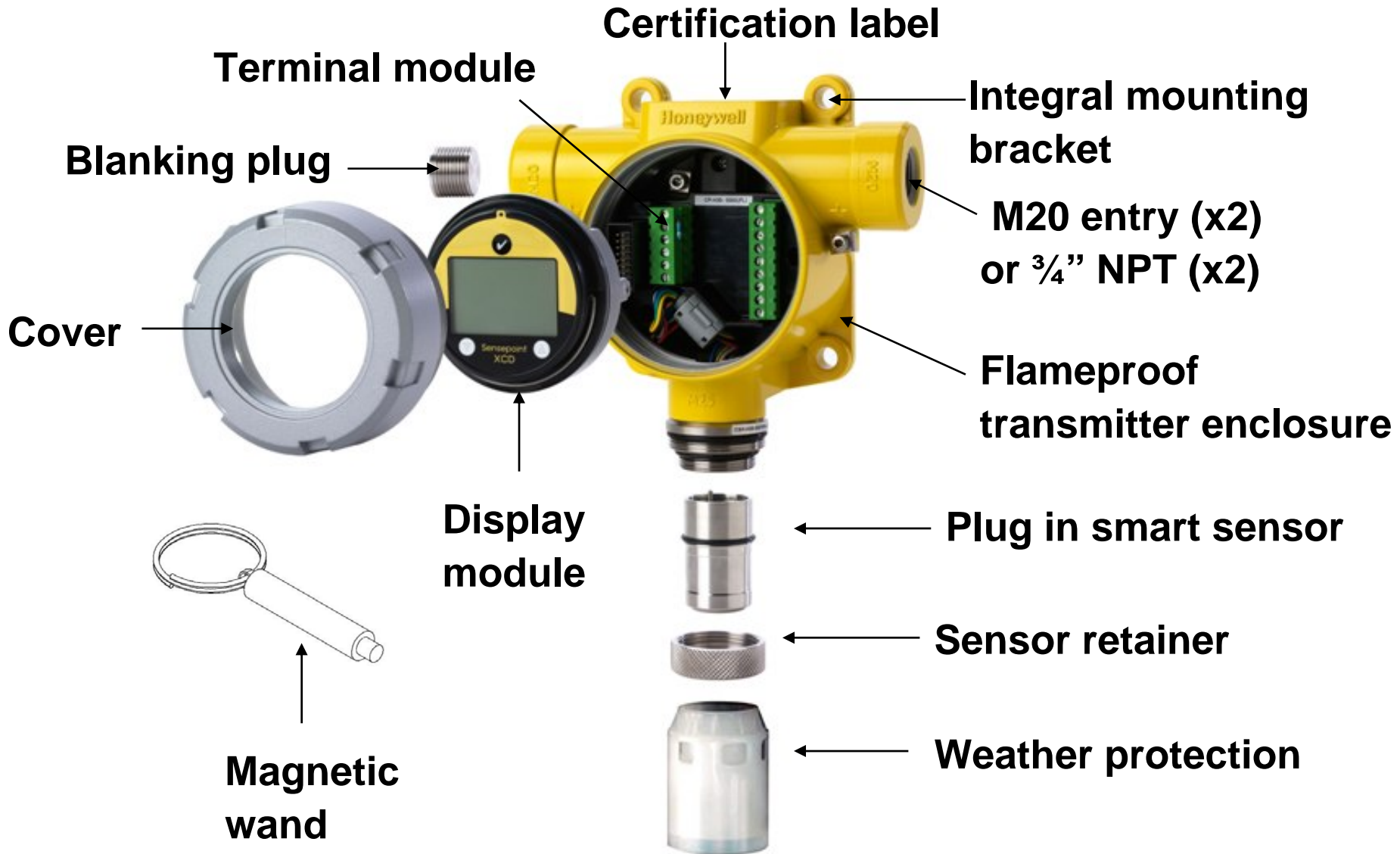

Sensepoint XCD Mechanical Data

- **Materials**

- **Painted Aluminium LM25**
 - ◆ General Industrial applications
- **Painted Stainless Steel 316**
 - ◆ Offshore and harsh environments
 - ◆ Food and beverage markets

- **Hazardous area certified**

- **UL, cUL, CSA, Inmetro, and ATEX**

- **Mounting**

- **4 x Integral mounting lugs**
- **Suitable for M8 bolts**
- **Optional Pipe or Duct mounting options (see following slides)**

- **Entries**

- **2 x ¾" NPT (UL/CSA versions)**
- **2 x M20 (ATEX/IECEX version)**
- **1 suitable blanking plug**
 - ◆ Must be suitably sealed to maintain IP rating

- **Outline dimensions:**

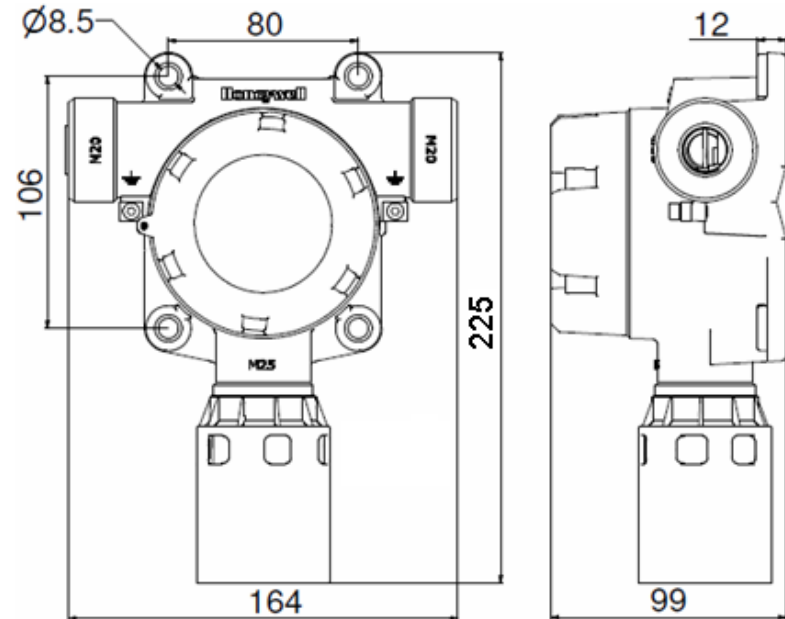

All dimensions in mm. 1" = 25.4 mm

Sensepoint XCD Optional Accessories

- **Pipe mounting bracket**
 - The transmitter may be fixed directly to a horizontal or vertical pipe/structure
 - Suitable for pipes $\text{Ø}40.0\text{-}80.0\text{mm}$ ($\text{Ø}1.6$ to $3.1''$).
- **Duct mounting kit (For CO, H₂ and H₂S gas sensors only)**
 - Enables detection within ventilation duct with transmitter external to duct
 - **Square/rectangular ducts**
 - ◆ Minimum 1mm (0.04") duct wall thickness
 - **External gas inlet port**
 - ◆ Recommended for bump test only
 - ◆ Use calibration cup for calibration
 - ◆ Suitable for 6mm ($\frac{1}{4}''$) ID tubing

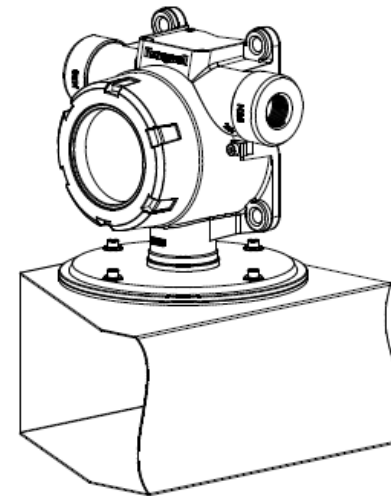
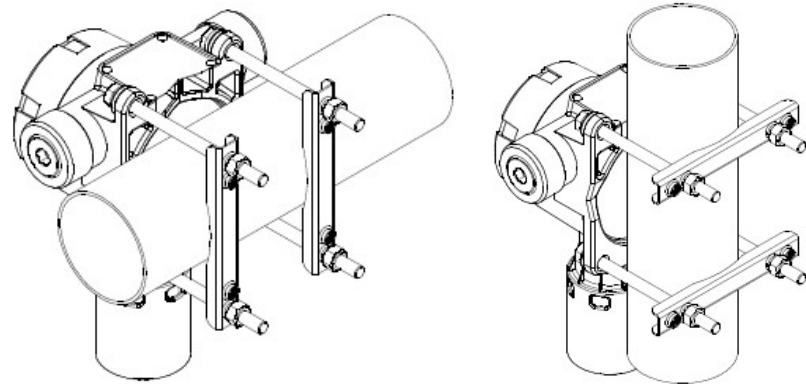

Sensepoint XCD Accessories

- **Sunshade/deluge cover**

- Designed to protect XCD from overheating in exposed hot and arid climates.
- Additional protection from thermal shock in Tropical Environments / water deluge conditions.
- Attaches to the integral mounting lugs

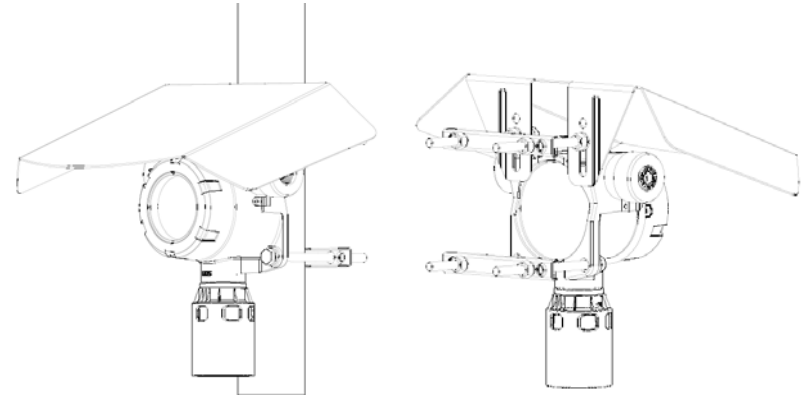

- **Weather protection with gassing port** (supplied as standard)

- Recommended for outdoor exposed applications
- **Gassing port**
 - ◆ Recommended for bump testing only
 - ◆ Suitable for 6mm (1/4") ID tubing

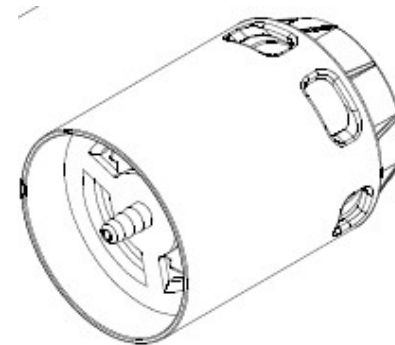

Sensepoint XCD Accessories

- **Magnetic Wand**

- For menu activation and changing settings

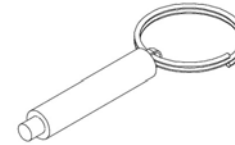

- **Gassing Cap**

- For applying calibration gases to sensor
- Use 6mm (1/4") ID tubing
 - ◆ 500ml/min for IR, toxic & O2
 - ◆ 1Ltr/min for catalytic

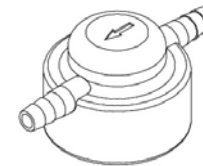

- **Collecting cone** (CO and H₂ only)

- To aid detection of lighter than air gases
- Stand off from wall required or ceiling mounting bracket

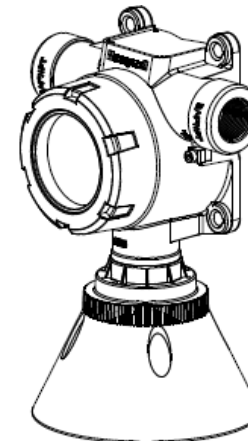

Sensepoint XCD Terminal Area

XCD Terminal Module

Internal Earth/Ground Point

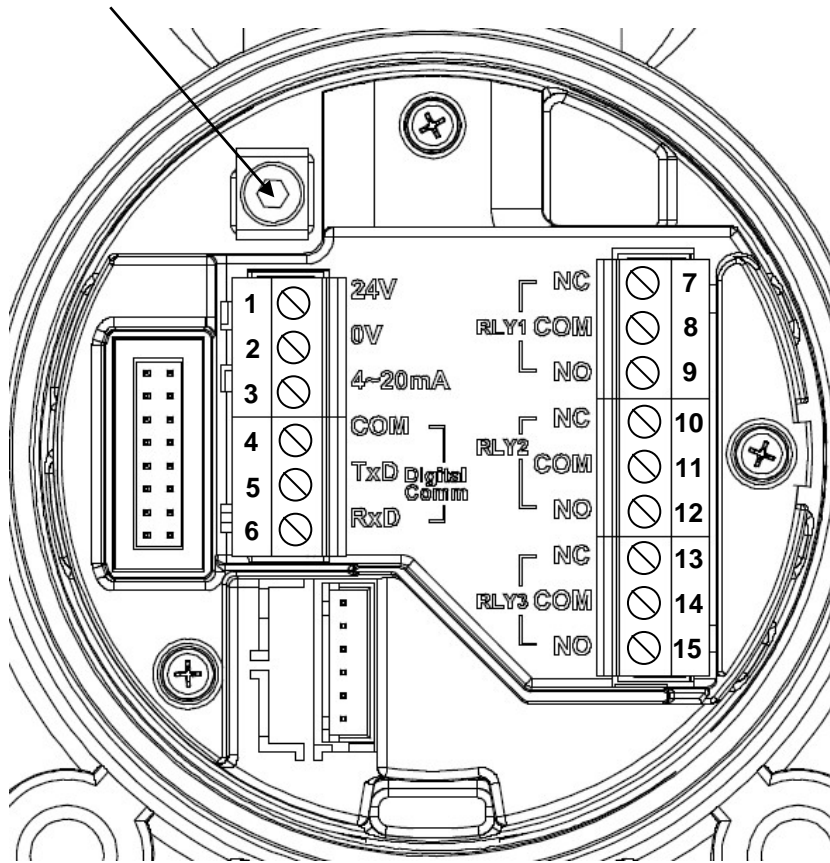

NOTE: Terminal blocks are plug/socket type and may be removed to ease wiring

Terminal Module Connections

Terminal Number	Marking	Connection	Description
1	24V	+VE Supply (16 - 32VDC)	Controller Connections
2	0V	-VE Supply (0VDC)	
3	4-20mA	Current Output Signal	
4	COM	Drain	MODBUS RTU, RS485 (Pending)
5	TxD	MODBUS B (+)	
6	RxD	MODBUS A (-)	Programmable Relay 1 (Default A1)
7	RLY1/NC	Normally Closed	
8	RLY1/COM	Common	
9	RLY1/NO	Normally Open	Programmable Relay 2 (Default A2)
10	RLY2/NC	Normally Closed	
11	RLY2/COM	Common	Programmable Relay 3 (Default Fault)
12	RLY2/NO	Normally Open	
13	RLY3/NC	Normally Closed	
14	RLY3/COM	Common	
15	RLY3/NO	Normally Open	

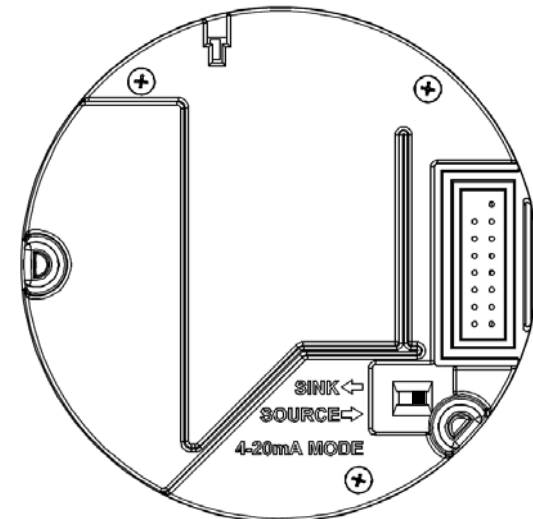

Rear View of 'Puck'

Sensepoint XCD Electrical Data

- **Output**

- **Industrial standard 4-20mA**
 - ◆ Sink or source switch selectable
- **Over range 22mA**
- **Fault $\geq 0.0 < 1.0$ mA**
- **Inhibit (Selectable)**
 - ◆ Flam/Toxic: 2mA or 4mA (Oxygen 2mA or 17.4mA)

- **Supply voltage**

- **16 to 32Vdc (24Vdc nominal)**

- **Power consumption (max)**

- **Cat: 4.9W, ECC: 3.7W, IR: 3.7W**

- **Wiring**

- **Suitable mechanically protected cable/conduit and glands**
- **3 core plus screen**
 - ◆ 90% coverage preferred
- **0.5mm² to 2.5mm² (Approx. 20 to 14AWG) cable**
 - ◆ Ensure min required voltage at detector is 16Vdc

Current Source Wiring Schematic

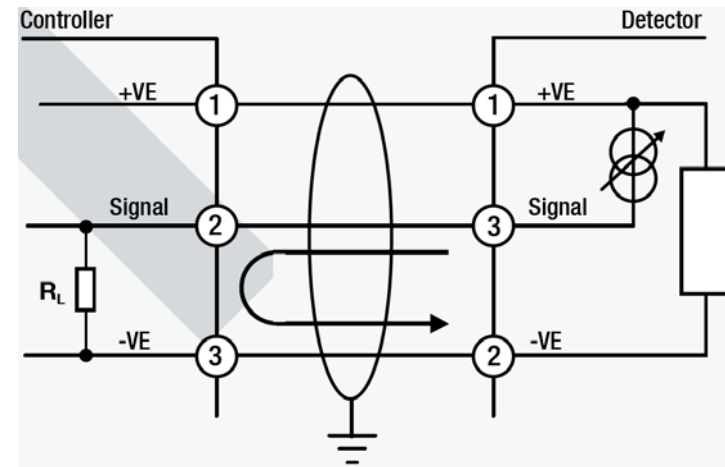

Current Sink Wiring Schematic

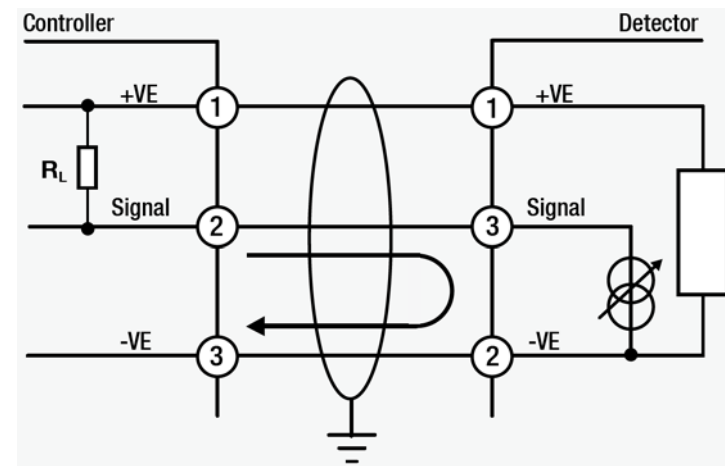

NOTE: To avoid ground loops, terminate screen at detector or controller, not both

Sensepoint XCD Cable Length Calculation

The following table shows the maximum cable distances between the controller and transmitter assuming a voltage drop of 4V *in each core* and for different cable parameters.

The table contains examples only and actual cable parameters and source power supply voltage for the application should be used to calculate the maximum cable distance allowed at the installation site. See the manual for details of making maximum cable length calculations using actual parameters.

Typical cable data			Maximum cable length					
Cable size (cross sectional area)	Cable resistance		Catalytic		ECC		IR	
	Ω/km	Ω/mi	Metres	Feet	Metres	Feet	Metres	Feet
0.5mm ² (20AWG*)	36.8	59.2	356	1167	478	1568	420	1379
1.0mm ² (17AWG*)	19.5	31.4	671	2201	902	2956	793	2599
1.5mm ² (16AWG*)	12.7	20.4	1031	3387	1384	4549	1217	4000
2.0mm ² (14AWG*)	10.1	16.3	1296	4239	1741	5694	1531	5006
2.5mm ² (13AWG*)	8	12.9	1636	5356	2197	7194	1932	6326
* Nearest equivalent								

Sensepoint XCD Sensor Families

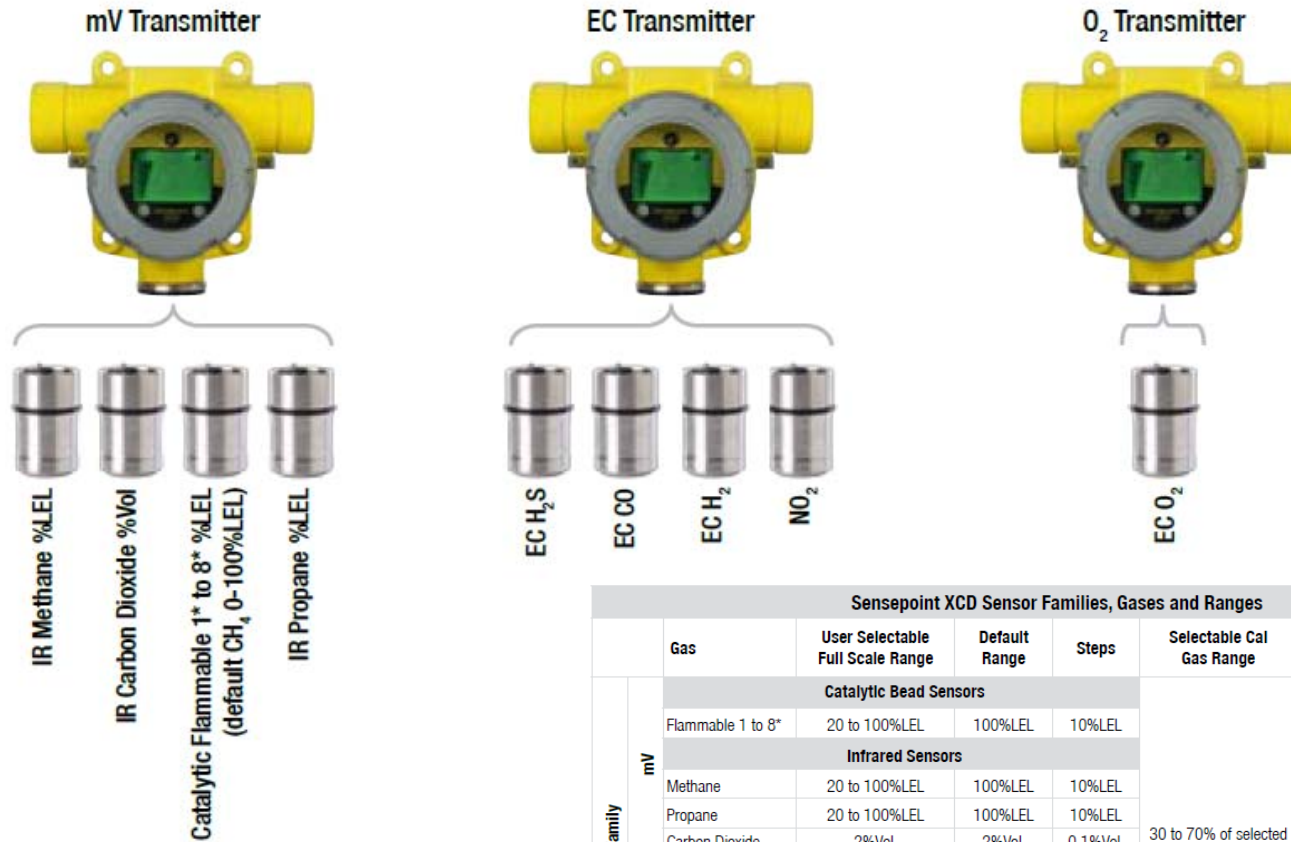

Sensepoint XCD Sensor Families, Gases and Ranges								
	Gas	User Selectable Full Scale Range	Default Range	Steps	Selectable Cal Gas Range	Default Cal Point		
Sensor Family	Catalytic Bead Sensors							
	mV	Flammable 1 to 8*	20 to 100%LEL	100%LEL	10%LEL	30 to 70% of selected full scale range	50%LEL	
		Infrared Sensors						
		Methane	20 to 100%LEL	100%LEL	10%LEL		50%LEL	
		Propane	20 to 100%LEL	100%LEL	10%LEL		50%LEL	
	Carbon Dioxide	2%Vol.	2%Vol.	0.1%Vol.	1%Vol.			
	Electrochemical Sensors							
	EC	Hydrogen Sulfide	10 to 100ppm	50.0ppm	0.1ppm		10ppm	
		Carbon Monoxide	100 to 1,000ppm	300ppm	100ppm		100ppm	
		Hydrogen	1,000ppm only	1,000ppm	n/a		500ppm	
Nitrogen Dioxide		10 to 50ppm	10ppm	5ppm	5ppm.			
O ₂	Oxygen	25%Vol. only	25%Vol.	n/a	20.9%Vol. (Fixed)	20.9%Vol.		

*Contact HA for Availability of %Vol. IR

Ultra-clear Backlit Display & Status Indication Honeywell

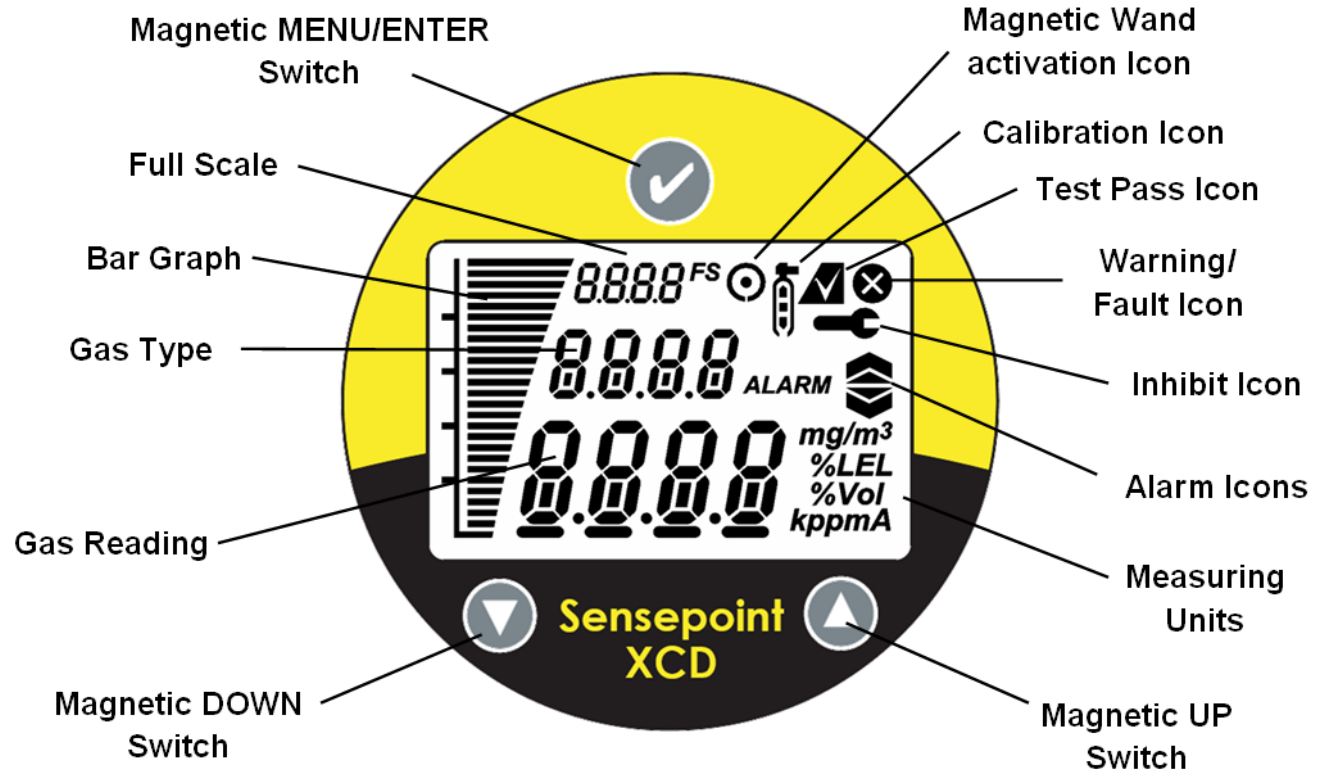
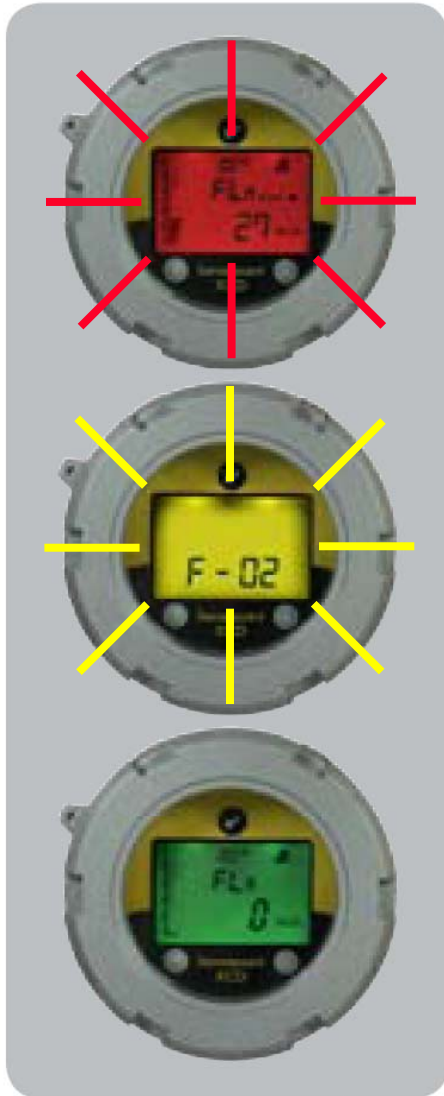

- Tricolour backlit LCD
- Instantly recognisable 'Traffic Light' colours
- Clear indication of unit status- even from a distance

Sensepoint XCD Status Outputs

System Status						
Status	Display	Current Output	Relay			Back Light
			A1	A2	Fault	
Fault: Circuit or sensor error	F-XX fault number with fault icon blinking	0-1.0 mA			✓	Yellow, flashing
System Fault	N/A	0-0.15mA				
Note: In the event of processor failure the watchdog will automatically reset the system for recovery.						
Warning	W-XX warning number with fault icon blinking	Dependent on system status				Green Steady
Normal	0.0 Gas concentration	4-20 mA				Green Steady
Alarm 1	Gas concentration. 1 st alarm icon blinking	4-20 mA	✓			Red, flashing
Alarm 2	Gas concentration. 2 nd alarm icon blinking	4-20 mA	✓ ¹	✓		Red, flashing
Over-range	Full scale icon and reading blinking	22mA	✓	✓ ²		Red, flashing
Inhibit	Inhibit icon dependent on Menu command. If any relay is set to inhibit relay, then inhibit relay will be activated.	2 or 4mA depending on configuration. Note: 2 or 17.4mA for Oxygen version				Green Steady



Note:

1. For Oxygen, A1 relay will not be activated because AL1 is configured to activate above 23.5 %Vol (in Rising Alarm configuration).
2. For Oxygen, A2 relay will not be activated because AL2 is configured to activate below 19.5 %Vol (in Falling Alarm configuration).

Sensepoint XCD Warning Codes

Message	Description	Action
W-01	Calibration overdue	Re-calibrate detector Disable warning
W-02	Transmitter Temperature limits exceeded	Use '✓' to clear when within limits
W-03	Alarm setting needs to be configured	Re-configure alarm settings such that upper alarm should not exceed user configured scale.
W-04*	Over-range warning	Use '✓' to clear when within limits
W-05*	The sensor is switched off to prevent it from being deteriorated	Make sure that there is no flammable gas in the air and use '✓' to clear when within limits

***Note :** W-04 and W-05 are only for flammable catalytic bead sensors. For other gases, gas reading will blink on the LCD instead of the over-range warning.

Sensepoint XCD Fault Codes

Message	Description	Action
F-01	Internal I2C failure	Cycle power to detector. Replace detector
F-02	Cell failure	For Toxic, replace sensor For Flammable/IR, cycle power to detector. Replace sensor
F-03	Significant zero drift	Re zero/calibrate
F-04	Unexpected sensor fitted	Replace sensor
F-05	EEPROM is corrupted	Replace detector
F-06	Low supply voltage	Replace detector
F-07	SRS processor failure	Replace detector
F-08	RAM read/write fault	Replace detector
F-09	Info. memory corrupted	Replace detector
F-10	Code Memory corrupted	Replace detector
F-11	DAC output failure	Replace detector
F-12	Heater failure	Replace detector
F-13	Supplied voltage failure	Check supply voltage. Replace detector

Sensepoint XCD Menu Modes

Menu	Display	Description
Set Calibration	SEt CAL	Execute zero/span calibration Set calibration gas level
Set Range	SEt rAng	Set measuring range
Configure Inhibit	CONF Inhb	Select inhibit current Set timeout option (5 minute increments)
Set Password	SEt PASS	Enable/disable password Set password Default – no password (Select '0000')
Set Calibration Interval	CAL Int	Set calibration interval, 30 to 365 days User configurable option to display warning
Bump Test	bump tEST	Execute a 'bump' test to check gas response of the sensor.
Force Current	forc Curr	Force analogue output to test functionality of GD control system during system commissioning.
Set Alarms	SEt ALrm	Set alarm 1, alarm 2 levels, functionality and operation (none/falling/rising)

Sensepoint XCD Menu Modes (Cont'd)

Menu	Display	Description
Set Relays	SEt rLy	Set relay 1,2,3 type (alarm 1, alarm 2, fault and inhibit) and action (energized/de-energized)
Relay Operation	rLy OPr	Configure relay on delay time, relay off delay time and latch/non-latch
Set Location	SEt Loc	Set location (or TAG number)
Set Temperature Unit	tEmP Un It	Change temperature display unit. °C (Celsius) or °F (Fahrenheit)
Check Alarm Functions	tEst ALr m	Simulate alarm situation to check the alarm system without gas present at the sensor
Quit	Qu It	Return to Monitoring mode

Sensepoint XCD Commissioning/First time Start Up

1. Remove the transmitter housing cover and detach the display unit by lifting the semicircular handle and pulling the assembly directly away from the termination module (without twisting it)
2. Configure the detector's analogue output signal configuration for Current SINK or Current SOURCE operation using the selector switch located on the back of the display module. (The default setting is Current SOURCE).
3. Check that all electrical connections are terminated correctly and the correct sensor is fitted for transmitter type.
4. Switch on the external power supply to the transmitter at the safe area gas detection controller (or PLC).
5. Using a Digital Multi Meter (DMM), check the Supply Voltage at the terminals 1 (24V) and 2 (0V), this should be a minimum supply voltage of 16Vdc (Maximum supply voltage is 32V DC)
6. Switch Off the external power to the detector.
7. Refit the Display Module and Cover.
Note: Ensure that none of the wires in the terminal area cause an obstruction when refitting the Display Module. Ensure that the socket on the Display Module is fully engaged in the Display Module Connector on the Terminal Module.
8. Switch on external power to the detector.
9. All the display icons/text/numbers are displayed for 3 seconds.
10. The start up sequence will then be displayed.
11. The warm up countdown of 60 seconds (depending on the gas type) is then displayed.
12. Normal Monitoring Mode is Displayed.

Sensepoint XCD Calibration and Bump Test Honeywell

Response Check and Calibration

It is recommended to periodically carry out a gas response check on the Sensepoint XCD to ensure correct operation. This may be done in two ways;

A simple Response Check often referred to as a “BUMP TEST” is a test using calibration gas applied to the sensor via the nozzle of the Weather Protection or using the Sensepoint XCD Gassing Cap. If a BUMP TEST is done via the Weather Protection nozzle it may be necessary in windy conditions to increase the flow rate of the test gas by a further 1 LPM, OR, to shelter the weather protection from the wind.

A full gas calibration of the sensor as described in the following section, using ONLY the Sensepoint XCD Gassing Cap (Part No.: S3KCAL).

Zeroing and span calibration

Note: the Oxygen sensor does not require a zeroing procedure. Background air (20.9%Vol oxygen) can be used to span the oxygen sensor in place of a compressed air cylinder (20.9%Vol oxygen). For oxygen sensors only do parts 1-4, 12, 13 (if compressed air cylinder is used), 14-17 and 22 of the procedure below.

Caution: Before initial calibration allow the detector to stabilize for 30 minutes after applying power. When in zeroing and span calibration mode the current output from the detector is inhibited (default 2mA) to avoid false alarms. For Flammable gas calibration use a calibration gas concentration of between 25%LEL and 75%LEL to ensure that the required accuracy can be attained. For Hydrogen Sulphide type sensors refer to section 10.1.2 before conducting zero and span calibration.

To calibrate the detector, use an appropriate span gas cylinder, constant flow regulator AND the Sensepoint XCD Gassing Cap. The flow rates used for calibration gas are as follows: 500ml/min for IR, Toxics and O₂, 1 Ltr/min for catalytic bead sensors.

A compressed air cylinder (20.9%Vol oxygen) should be used to perform the zero calibration if the area where the detector is located contains any residual amount of the target gas. If no residual gas is present then the background air can be used to perform the zero calibration.

To calibrate the detector follow the procedure following.

Sensepoint XCD Zero Calibration

1. If the ambient air is NOT considered reliable to use to set the ZERO, then remove the weather protection and fit the Gassing Cap accessory onto the sensor and apply a clean source of zero gas or compressed air.
2. To access the calibration menu, hold the end of the magnet over the switch located at the top centre of the detector display (✓) for at least 3 seconds and then remove.
3. The display will indicate the first configuration mode menu 'SEt CAL'.
4. Put the magnet over the '✓' switch again and move to enter the Calibration menu.
5. The display will show the current gas reading, and the 'ⓘ' icon flashes.
6. When the zero gas reading is stable use '✓' to confirm zero calibration.
7. If successful the display shows 'ZEro PASS' (if not successful, the display shows 'Zero FAIL' and returns to configuration mode).
8. If using zero-air, turn it off. Zeroing is complete and saved.
9. The display shows 'SPAN' with 'YES' flashing.
10. If span calibration is required use '✓' proceed to the next step. If span calibration is not required, use '▲ ▼' to select 'No' and '✓' to return to configuration mode.

Sensepoint XCD Span Calibration

11. The display shows the current calibration span gas concentration while flashing the '🔧' icon. Use '▲▼' to change the calibration span gas concentration, and '✓' when required span calibration level is set.
12. The display will show the current gas reading, and the '🔧' icon flashes.
13. Connect the regulator to the span gas cylinder.
14. Apply the span gas to the sensor using the Sensepoint XCD Gassing Cap. The live gas reading is displayed. When the reading is stable, use '✓' to confirm span calibration.
15. If the sensor has been replaced the 'Replace Sensor' display may be shown.
16. Use '▲▼' to select 'YES' if the sensor has been replaced or 'No' if it has not been replaced.
17. If the span calibration is successful the instrument will briefly display 'SPAN PASS' (if fails 'SPAN FAIL' displayed and returns to configuration mode).
Note: the calibration due warning counter is reset after a successful calibration.
18. The display alternates between "Purg gAS" and the gas reading to indicate that the unit is expecting the span gas to be removed from the sensor.
19. Promptly switch off the calibration span gas and remove the Sensepoint XCD Gassing Cap from the sensor to allow the gas to disperse.
20. When the reading falls below 50% of the calibration gas level the display indicates a countdown (up to 180 seconds dependant on gas type).
21. When the countdown is finished, the calibration procedure is complete.
22. The instrument returns to the 'Set CAL' menu. Activate the '▲' or '▼' switch to select another menu or select 'QuIT' to return to normal monitoring mode.

Sensepoint XCD H2S Zero & Span Calibration Honeywell

Hydrogen Sulphide sensors can be affected by extreme humidity changes. A sudden increase in ambient humidity can result in a short-term positive drift in the instrument's reading. A sudden decrease in ambient humidity can result in a short-term negative drift in the instrument's reading. These are most likely to be noticed during calibration with dry or cylinder gas.

When calibrating Hydrogen Sulphide cartridges the following should be taken into account:

1. To zero the sensor, use a compressed air cylinder of 20.9%Vol oxygen (not Nitrogen). Do not use background air.
2. Apply the gas to the sensor for three minutes before using '✓' to confirm the zero calibration.
3. If a span calibration is to be performed, the span calibration gas should be applied to the sensor immediately after the zeroing procedure. Do not allow the sensor to return to ambient air conditions between steps 2 and 3.
4. Apply the span gas for two minutes before using '✓' to confirm the span calibration.

Sensepoint XCD Bump Test

1. To access the Bump Test menu, hold the end of the magnet over the switch located at the top centre of the detector display (✓) for at least 3 seconds and then remove.
2. The display will indicate the first configuration mode menu 'SEt CAL'.
3. Use '▲ ▼' to select the 'Bump Test' Menu.
4. Put the magnet over the '✓' switch again and move to enter the Bump Test menu.
5. The display will show the current gas reading, and the word 'PEAK' and inhibit icon '⚡' flashing.
6. Apply the bump test gas to the nozzle of the weather housing.
7. The display will start to rise according to the gas applied and will hold the display at the peak gas reading made.
8. Remove the bump test gas from the weather housing nozzle.
9. Use '✓' and the display will switch from the peak reading to the actual current live gas reading (falling).
10. Wait for the current gas reading to fall below the low alarm level before using '✓' to return to the menu mode and returning to normal mode.

WARNING: Failure to allow the current gas reading to fall below the low alarm level before returning to normal mode will result an alarm condition.

- Honeywell Analytics recommends that gas detectors are tested and re-calibrated on a six monthly basis, or according to site practice.
- The pellistors used in the Catalytic flammable gas sensor can suffer from a loss of sensitivity when in the presence of poisons or inhibitors, e.g. silicones, sulphides, chlorine, lead or halogenated hydrocarbons. The pellistors are poison resistant to maximize the operational life of the Catalytic flammable sensor. A typical operating life, subject to the presence of poisons/inhibitors is 36 months.
- The NDIR (infrared) flammable gas sensor is not affected by the above-mentioned poisons and therefore has a longer life span.
- Typical life of a toxic gas sensor is dependant on the application, frequency and amount of gas exposure. Under normal conditions (3 monthly visual inspection and 6 monthly test/recalibration), the XCD Oxygen and other toxic sensors have an expected life equal to or greater than 24 months.

XCD Sensor Replacement

The Sensor cartridges used in Sensepoint XCD have no serviceable parts. When they have reached their end of life, simply replace with a new one using the procedure below:

1. Remove the Power from the Sensepoint XCD Transmitter
2. Remove the Weather Protection or other accessories from the sensor socket thread.
3. Loosen the Locking Grub Screw and unscrew the Sensor Retainer
4. Carefully pull the old Sensor from the sensor socket without twisting.
5. Fit the new Sensor in its place.
6. Recalibrate the sensor.

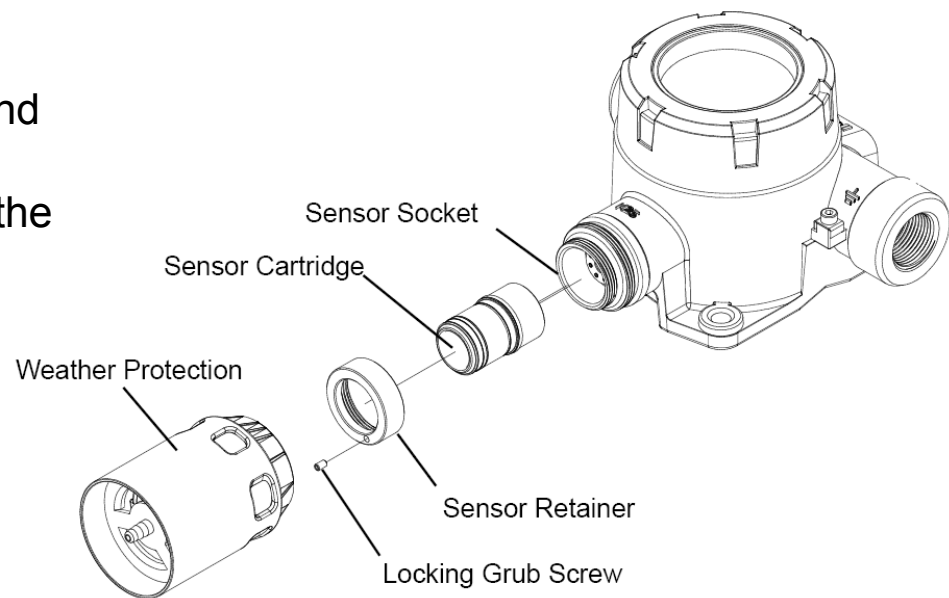

XCD Module Replacement

Two replaceable module assemblies are located within the transmitter housing: The Display Module and the Terminal Module.

The Display Module is simply removed by unplugging it from the Terminal Module (this procedure is done during normal installation).

To replace the Terminal Module, use the following procedure:

1. Unscrew and remove the Transmitter Cover
2. Lift the handle and un-plug and remove the Display Module.
3. Unplug the connection terminals and lift them clear of the Terminal Module.
4. Unplug the connector for the XCD sensor.
5. Loosen and remove the three “cross-headed” screws that secure the Terminal Module to the Transmitter housing.
6. Carefully lift the Terminal Module from the transmitter housing.
7. Fit the new Terminal Module using the above procedure in reverse order.

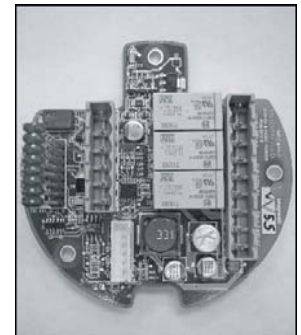
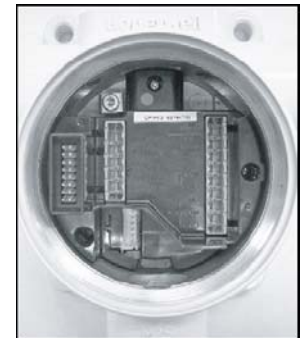
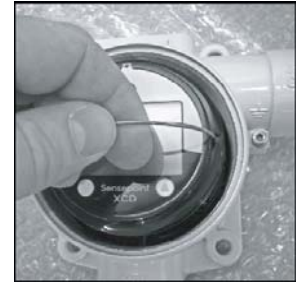

XCD Module Overview

- Modbus® protocol is a Master-Slaves protocol.
- Only one master (at the same time) is connected to the bus and one or up to 32 slave nodes are also connected to the same serial bus.
- Modbus® communication is always initiated by the master. The slave nodes will never transmit data without receiving a request from the master node.
- The slave nodes will never communicate with each other. The master node initiates only one Modbus® transaction at the same time.

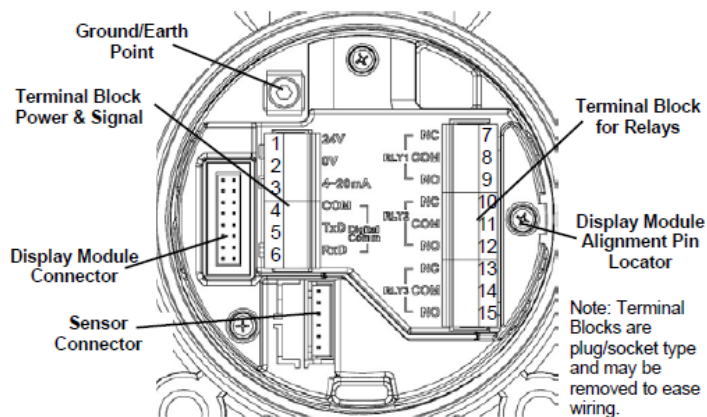

Terminal Module Connections			
Terminal Number	Marking	Connection	Description
1	24V	+VE Supply(16-32VDC)	Controller Connections
2	0V	-VE Supply(0VDC)	
3	4~20mA	Current Output Signal	
4	COM	Common	MODBUS RTU. RS485 (Optional)
5	TxD	MODBUS A(+)	
6	RxD	MODBUS A(-)	Programmable Relay 1 (Default A1)
7	RLY1/NC	Normally Closed	
8	RLY1/COM	Common	
9	RLY1/NO	Normally Open	Programmable Relay 2 (Default A2)
10	RLY2/NC	Normally Closed	
11	RLY2/COM	Common	
12	RLY2/NO	Normally Open	Programmable Relay 3 (Default Fault)
13	RLY3/NC	Normally Closed	
14	RLY3/COM	Common	
15	RLY3/NO	Normally Open	

XCD Module network ID setting

Set id>>Set ModBus slave ID>>Set Baud rate>>Set Parity

- 1) Slave ID shall be set 1~247
- 2) Baud rate setting 9600 or 19200
- 3) Parity setting (No, Even, Odd)

From the Configuration Mode screen, select '✓'. To set the ModBus Slave ID, use the up-down '▲▼' switches to move to the desired position and use '✓' to select it. Again, using the '▲▼' switches, increment or decrement the value until the desired value appears, selects the value and moves to the next setting.

The communications baud rate and Parity Setting can also be set from this screen by using the '▲▼' switches to navigate to the baud rate display then selecting '✓'. Using the '▲▼' switches, highlight the proper baud rate or parity setting and select '✓'. Default is Slave ID 1, 19200bps and even parity.

Note: Set ID menu is available only for XCD equipped with Modbus option.

