



**Sensors Type 705  
Combustible Gas Sensor UI Certified**

---

## HELPING TO MAKE A SAFER WORLD

---

Ensure that you read and understand these operating instructions BEFORE installing or operating any part of the equipment.

Please pay particular attention to the Safety Warnings.



### WARNINGS

1. To maintain safety standards, regular maintenance, calibration and operation of this equipment by qualified personnel is essential. Read and understand this manual completely before operating or servicing. If any further details are required which do not appear in this manual contact Zellweger Analytics Limited or their agent.
2. The Code of Practice regarding 'Selection, Installation and Maintenance of Electrical Apparatus for use in Potentially Explosive Atmospheres' must be complied with at all times. Refer to the appropriate local or national regulations relative to the installation site.

Elsewhere the appropriate local or national regulations should be used.

3. Operators must be fully aware of the action to be taken if the gas concentration exceeds an alarm level.

### CAUTION

To maintain safety standards, regular maintenance, calibration and operation of the equipment by qualified personnel is essential.

---

## HELPING TO MAKE A SAFER WORLD

---

### IMPORTANT NOTICES

1. Zellweger Analytics Limited can take no responsibility for installation and/or use of its equipment if this is not done in accordance with the appropriate issue and/or amendment of the manual.
2. The user of this manual should ensure that it is appropriate in all details to the exact equipment to be installed and/or operated. If in doubt, the user should contact Zellweger Analytics Limited for advice.
3. If further details are required which do not appear in this manual, contact Zellweger Analytics Limited or one of their agents.

### HELP US TO HELP YOU

Every effort has been made to ensure the accuracy in the contents of our documents, however, Zellweger Analytics Limited can assume no responsibility for any errors or omissions in our documents or their consequences.

Zellweger Analytics Limited would greatly appreciate being informed of any errors or omissions that may be found in the contents of any of our documents and to this end we include the form opposite for you to photocopy, complete and return to us so that we may take the appropriate action.



---

## CONTENTS

---

Section	Page
1. INTRODUCTION	7
1.1 General	7
1.2 Principle of Operation	6
1.3 Accessories	6
2. INSTALLATION	12
2.1 Unpacking	12
2.2 Sensor Orientation	12
2.3 Terminal Housings	12
2.4 Cable Connections	13
2.5 Fitting Sensors	14
3. FITTING ACCESSORIES	16
3.1 Collecting Cone	16
3.2 Weather Protection Housing	16
3.3 Sample Flow Housing	16
3.4 Filter	17
4. MAINTENANCE	18
4.1 General	18
4.2 Cleaning	18
5. GASSING THE SENSOR	19
5.1 Sensor without Accessories	19
5.2 Sensor with Collecting Cone or Weather Protection Housing	19
5.3 Sensor with Sample Flow Housing	19
6. REPLACEMENT PARTS	21
6.1 Terminal Housings	21
6.2 Maintenance Spares	21
7. TYPE 705 SENSOR ALTERNATIVE SYSTEMS	22
8. SPECIFICATION	23



---

# 1. INTRODUCTION

---

## 1.1 GENERAL

The 705 Sensor (Figure 1) is a combustible gas detector certified for installation in a hazardous area. This version uses the catalytic principle and in conjunction with electronic control equipment situated in a non-hazardous area it forms a combustible-gas detection system. The type of sensor and the gas to be detected should always be quoted when ordering replacement sensors.

The sensor comprises an aluminum housing containing a pair of poison resistant detector elements, with a sintered stainless steel disc forming the face of the sensor. The housing has a 47mm AF body with a 3/4 NPT mounting thread at one end and an M36 accessory thread on the other end. A plastic Filter Housing screws on to the accessory thread and holds the filter in position, if required. There are a number of accessories available for the 705 Sensor which utilise the M36 accessory thread. Refer to Section 8 for alternative systems to which the 705 Sensor can be connected.

*Note: New Sensors are despatched with a protection disc in place of a filter. This disc should not be removed until the sensor is installed or commissioned.*

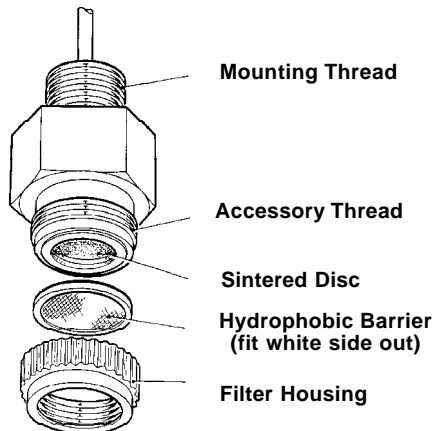

**Figure 1 Type 705 Sensor and Filter Housing**

---

# 1. INTRODUCTION

---

## 1.2 PRINCIPLE OF OPERATION

The Sensor contains two elements which are heated by a supply derived from the associated electronic control equipment. One element is sensitive to the presence of combustible gas, the element temperature increasing in response to catalytic oxidation of the gas. The resultant rise in resistance of the sensitive element, proportional to gas concentration, is processed by the associated control module.

The non-sensitive element compensates for effects of changes in ambient temperature.

The sensor drive current is set to a value appropriate to the type of elements used.

## 1.3 ACCESSORIES

### 1.3.1 General

The following accessories are available for use with the sensors:

- a. Collecting Cone (Figure 2).
- b. Weather Protection Housing (Figure 3).
- c. Sample Flow Housing (Figure 4).
- d. Hydrophobic Barrier.
- e. Gassing Point Assembly (Figure 5).

### 1.3.2 Collecting Cone

The detection of a lighter than air gas is enhanced by the use of a Collecting Cone. The cone fits onto the Sensor accessory thread in place of the Filter Housing and retains the filter. The appropriate filter must be fitted.

---

# 1. INTRODUCTION

---

A nozzle on the cone permits gassing of the Sensor with the cone in position. Test gas is applied either direct to the nozzle or via a permanently connected pipe-line when the Sensor is in an inaccessible location.

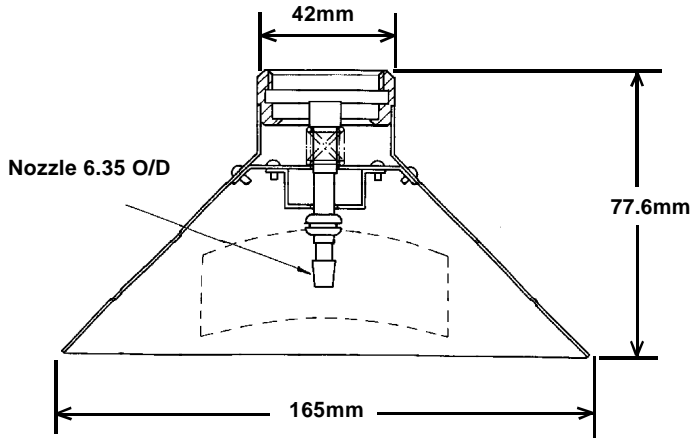

**Figure 2 Collecting Cone**

## 1.3.3 Weather Protection Housing

The Weather Protection Housing, fitted to a sensor installed in an exposed location, affords protection from driving rain from vertical to 30° below horizontal. When mounted close to the ground, protection is afforded from heavy rain rebounding off the ground. It also reduces contamination from industrial waste and enables the application of test gas in high wind speeds without significant error.

The housing is fitted to the sensor accessory thread in place of the Filter Housing and retains the Filter.

Incorporated in the housing is a nozzle to facilitate gassing of the sensor with the Weather Protection Housing in position, either by direct application to the nozzle or via a permanently connected pipeline. The nozzle is free to rotate within the housing to allow removal from the sensor without disconnecting a permanently connected pipeline, when changing the Hydrophobic Barrier and cleaning the sensor.

---

# 1. INTRODUCTION

---

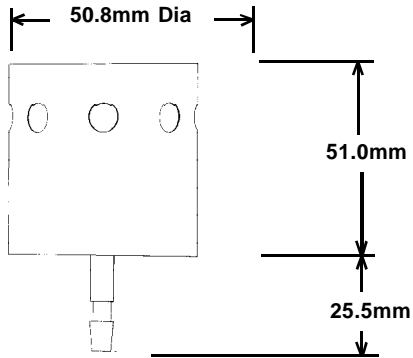

**Figure 3 Weather Protection Housing**

## 1.3.4 Sample Flow Housing

A Sample Flow Housing provides a facility to allow sampling of a closed system by means of two pipelines. The flow housing is fitted to the sensor accessory thread by a locking ring that enables the housing to be removed without disconnecting the pipeline. The Filter is retained by the pipeline and interfaces with a gasket bonded to the housing.

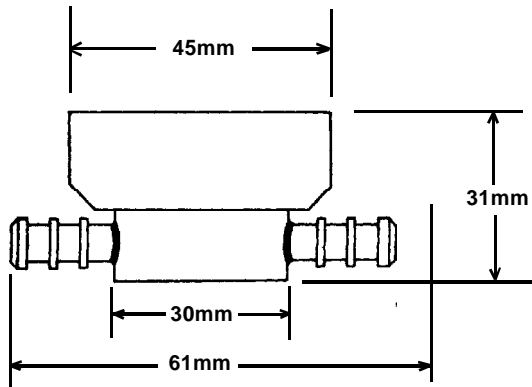

**Figure 4 Sample Flow Housing**

---

# 1. INTRODUCTION

---

## 1.3.5 Gassing Point Assembly

The Gassing Point Assembly can be fixed in a convenient position and permanently connected by suitable tubing to an inaccessible sensor, thus simplifying the application of test gas when checking sensor calibration. A DIN Rail Mounting Assembly (00785-A-0069) is available to enable five gassing point assemblies to be mounted side by side.

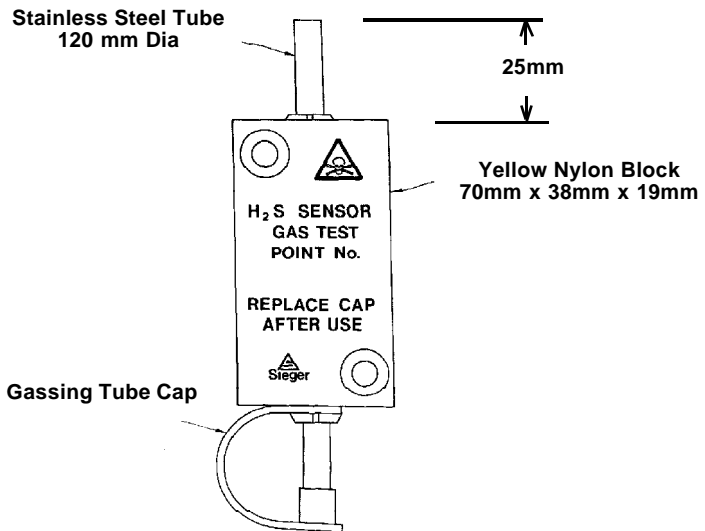

Figure 5 Gassing Point Assembly

## 1.3.6 Filters

In a clean atmosphere, and where no accessories are to be fitted, a filter is not needed. It is however mandatory that a filter should be fitted to provide protection appropriate to the environment and to complete the seal when a Weather Protection Housing or Collecting Cone is fitted.

## 1.3.7 Stainless Steel Filter

Two layers of stainless steel mesh in the form of a disc with a rubber rim to provide mechanical protection of the sinter and exclude large dust particles.

---

## 2. INSTALLATION

---



### WARNING

The Code of Practice regarding 'Selection, Installation and Maintenance of Electrical Apparatus for use in Potentially Explosive Atmospheres' must be complied with at all times. Refer to the appropriate local or national regulations relative to the installation site.

### CAUTIONS

1. The catalytic detector element is resistant to catalyst poisons, however, abnormally high concentrations of halogenated hydrocarbons, vapours of heavy metals or compounds, some silicone compounds and sulphur compounds may cause loss of sensitivity.
2. The type 705 Sensor must never be used in conditions where there is insufficient Oxygen to totally oxidise the combustible gas. For most combustible gases, an Oxygen level of at least 15% is sufficient.
3. The sintered disc on the sensor assembly must be kept free from contaminants. ie. Oil and dirt.

### 2.1 UNPACKING

On receipt the equipment must be carefully unpacked,, observing any instructions printed on the packaging, and the contents checked for deficiencies and transit damage.

### 2.2 SENSOR ORIENTATION

The sensor must be installed with the Sensor facing downwards. In exposed locations a Weather Protection Housing should be fitted.

### 2.3 TERMINAL HOUSINGS

A Terminal Housing (Figure 6) provides a mounting base for the sensor and contains the associated electronic circuit. The installation wiring enters the Terminal Housing via conduit.

---

## 2. INSTALLATION

---

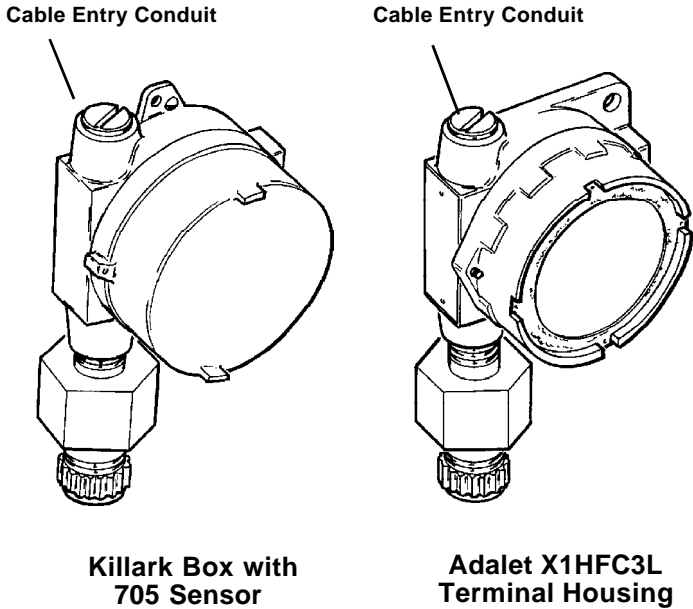

Figure 6 Terminal Housings

### 2.4 CABLE CONNECTIONS

The sensor is connected by three wires:

Connections		Colour Code
Sensitive	(S)	Brown
Non-sensitive	(NS)	Blue
Common	(01)	White

A 3-way terminal block is provided in the terminal enclosure to enable connection to be made to the control unit. Earthing facilities are available if required.

---

## 2. INSTALLATION

---

### 2.5 FITTING SENSORS



#### WARNINGS

Before installing the sensors, isolate the power supply by disconnecting or removing the associated control module from the installation.

#### CAUTION

1. The sensitivity of catalytic sensors is impaired by silicone compounds. Do not expose the sensors to silicones or silicone-based products.
2. The sintered disc on the sensor assembly must be kept free from contaminants. eg. Oil and dirt.
3. The relevant site procedures must be obeyed at all times when opening the Terminal Housing or removing the sensor in a hazardous areas

When fitting a sensor to a metal thread, it is recommended that the mounting thread should be coated with an approved anti-seize compound, such as a light petroleum grease.

Refer to Section 8 for alternative systems to which the sensor can be connected. If replacing a sensor refer to CAUTION 1 in the Maintenance section.

To fit the 705 Sensor proceed as follows:

- (1) Remove the protection disc and fit the accessories as required. (Refer to Section 3).
- (2) Isolate the power supply and wait for five minutes.
- (3) Remove the Terminal Housing lid.
- (4) Pass the cable into the Terminal Housing and fit the sensor to housing. To comply with the certification requirements, a minimum of five threads must be engaged.

---

## 2. INSTALLATION

---

- (5) Connect the sensor cable to the terminal block. (See label adjacent to connector).
- (6) After mounting the Terminal Housing in the required location, connect the associated Control Module wiring to the terminal block (see label).
- (7) Replace and secure Terminal Housing lid.
- (8) If not already replaced by accessories, unscrew the Filter Housing, remove the protection disc and replace Filter Housing and gasket.

*Note: The Hydrophobic Barrier is retained in position by the Filter Housing, or one of the accessories.*

- (9) Connect power supply to the Sensor by reconnecting or replacing the associated Control Module.
- (10) Calibrate the system as detailed in the control equipment manual.

---

## **3. FITTING ACCESSORIES**

---

### **3.1 COLLECTING CONE (00780-A-0032)**

To fit the Collecting Cone Assembly to a sensor, carry out the following:

- (1) Remove the Filter Housing and gasket from the sensor.
- (2) Fit the Stainless Steel Filter.
- (3) Screw the Collecting Cone assembly onto the sensor accessory thread and tighten firmly by hand.

### **3.2 WEATHER PROTECTION HOUSING (00780-A-2076)**

To fit a Weather Protection Housing to a sensor carry out the following:

- (1) Remove the Filter Housing and gasket from the sensor.
- (2) Fit the Stainless Steel Filter.
- (3) Screw the Weather Protection Housing on to sensor accessory thread and tighten firmly by hand.

### **3.3 SAMPLE FLOW HOUSING (00780-A-0035)**

To fit a Sample Flow Housing to the sensor, carry out the following:

- (1) Remove the Filter Housing and gasket from the sensor.
- (2) Ensure that the Sample Flow Housing is fitted with its gasket (00780-C-0017).
- (3) Apply a thin coating of anti-seize compound, such as a light petroleum grease, to the sensor accessory thread.

---

## 3. FITTING ACCESSORIES

---

- (4) If required fit the Stainless Steel Filter, screw the Sample Flow Housing on to the sensor and tighten with a 40mm A/F spanner.
- (5) Set the sample flow rate to  $1.5 \pm 0.1$  litres per minute, unless otherwise directed in System installation instructions.

### 3.4 FILTER

The filter is retained in position on the sensor by either the Filter Housing, or one of the above accessories. When fitting a filter, keep it free from oil and dirt and other contaminants.

---

## 4. MAINTENANCE

---

### 4.1 GENERAL

Maintenance consists of cleaning the sensor and accessories, replacing gasket and the Hydrophobic Barrier and gassing the sensor when testing the system.



### CAUTIONS

1. The sensitivity of Catalytic Sensors is impaired by silicone compounds. Do not expose to silicones or silicone based products.
2. Dismantling of a sensor or a sensor installation by other than authorised engineers invalidates certification.

In the event of exposure to contaminant or prolonged exposure to high concentration of gas, the sensor should be operated for 24 hours in a clean environment and then recalibrated.

*Note: If the sensor is found to be faulty, or cannot be calibrated, the complete sensor must be discarded and replaced.*

### 4.2 CLEANING

Sensor and accessories may be cleaned using an industrial grade of methanol, providing the appropriate safety precautions are taken when handling this solvent. Whenever cleaning takes place, a new Filter must be fitted and the following precautions must be observed:



- a. Isolate power supply from the sensor by withdrawing the associated Control Module from the installation.
- b. Do not remove sensor from the installation.

---

## 5. GASSING THE SENSOR

---

### 5.1 SENSOR WITHOUT ACCESSORIES

Where there are no accessories fitted, it is recommended that a Sample Flow Housing is used when gassing the sensor. Where this is not possible, a suitable plastic bag may be used.

### 5.2 SENSOR WITH COLLECTING CONE OR WEATHER PROTECTION HOUSING

- (1) Using the rubber tubing, connect the test gas to the gassing nozzle or to the permanently connected tubing if fitted.



#### CAUTIONS

1. Upward pressure on the gassing nozzle of a Weather Protection Housing forces the nozzle against the sinter. Rotation of the nozzle may damage the sinter if a filter is not fitted.
  2. Direct gassing of the sensor via the nozzle on the Collecting Cone in wind speeds of greater than 5 metres per second may cause errors.
- (2) Set the flow rate to  $1.5 \pm 0.1$  litres per minute and test the system in accordance with the instructions in the appropriate system equipment manual.
  - (3) On completion, shut off the test gas and disconnect the rubber tubing.

### 5.3 SENSOR WITH SAMPLE FLOW HOUSING

- (1) Shut off the sample flow to the flow housing.
- (2) Disconnect the input pipeline from the input nozzle of the flow housing.

---

## 5. GASSING THE SENSOR

---

- (3) Using the rubber tubing, connect the test gas to the flow housing input nozzle.
- (4) Set the flow rate to  $1.5 \pm 0.1$  litres per minute and test the system in accordance with the instructions in the appropriate system equipment manual.
- (5) On completion, shut off the test gas and disconnect the rubber tubing.
- (6) Reconnect the input pipeline to the flow housing input nozzle and restore the sample flow.

## 6. REPLACEMENT PARTS

### 6.1 TERMINAL HOUSINGS

*Note: When ordering replacements, always quote the complete part number. Where a part number is not listed or known, state type, material, cable entry size and other relevant details.*

Part Number	Description	Cable Entry Thread
00704-A-1755	Adalet X1HFC3L Box Bulkhead mounting.*	3/4 NPT (2 entries)
00704-A-1756	Killark HKB-BC Box Bulkhead mounting.*	3/4 NPT (2 entries)

\* These two items may be sourced locally.

### 6.2 MAINTENANCE SPARES

When ordering replacements, always quote the complete part number.

Part Number	Description
00705-A-1732	Sensor Assembly (SG7B)
00705-A-1733	Sensor Assembly (SG16B)
00780-A-0032	Collecting Cone
00780-A-0035	Sample Flow Housing
00780-C-0048	Gasket (Flow Housing)
00780-A-2076	Weather Protection Housing
00780-F-0018	Filter Stainless Steel
00780-C-0038	Filter Housing
00780-C-0048	Gasket for use with Filter Housing when a filter is not fitted

## 7. TYPE 705 SENSOR ALTERNATIVE SYSTEMS

### TOXIC SYSTEMS

#### SAFE AREA

#### HAZARDOUS AREA

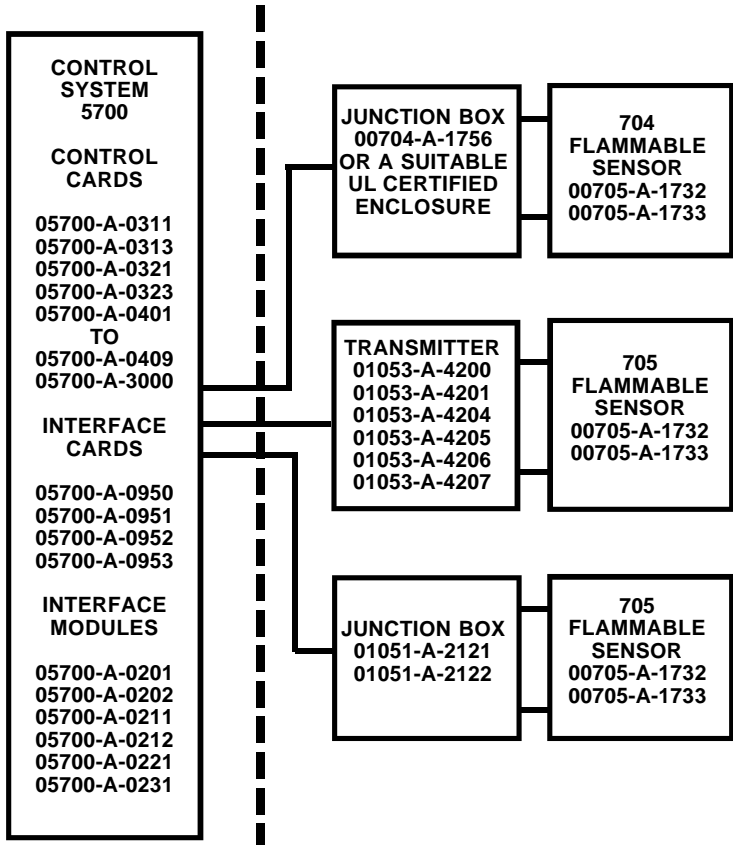

---

## 8. SPECIFICATION

---

### CERTIFICATION APPROVALS



Certified for Class 1, Division 1, Groups B, C and D

### DRIVE CURRENT

200mA  $\pm$  2mA (From control equipment).

### LINE RESISTANCE

Refer to Control Module Manual.

### MAXIMUM POWER DISSIPATION

Less than 1W.

### RESPONSE TIME

Time to reach 90% of a step change in gas concentration of 100% LEL methane - 13s.

Measured in accordance with the Canadian Standards Association (CSA) method of testing.

### AMBIENT TEMPERATURE RANGE

Operating: -40°C to +55°C.

Storage: -40°C to +55°C.

### TEMPERATURE COEFFICIENT OF ZERO POINT

Approximately 0.05% LEL Methane per °C (maximum).

---

## 8. SPECIFICATION

---

### HUMIDITY RANGE

Intermittent 0 to 100% RH non-condensing. Continuous 0 to 90% RH non-condensing.

### OVERALL DIMENSIONS AND WEIGHTS

#### Sensor:

Dimensions: 78mm x 55mm (47.2mm across flats).

Weight: 270g.

#### Killark HKB-BC Terminal Housing

Dimensions: 155mm x 135mm x 100mm.

Weight: 1.13kg.

#### Adalet X1HFC3L Terminal Housing

Dimensions: 115mm x 130mm x 88mm.

Weight: 1.2kg.

#### Collecting Cone:

Dimensions: 87mm x 165mm dia.

Weight: 175g.

#### Weather Protection Housing :

Dimensions: 76.5mm x 50.8mm dia.

Weight: 52.4g

#### Sample Flow Housing:

Dimensions: 61mm x 45mm x 31mm.

Weight: 110g

### TERMINALS

Screw clamped and accepting cable up to 2.5mm<sup>2</sup>.



**Find out more**

[www.honeywellanalytics.com](http://www.honeywellanalytics.com)

**Customer business centre  
Europe and the rest of the world**

Honeywell Analytics AG

Wilstrasse 11-U11

CH-8610 Uster

Switzerland

Tel: +41 (0)44 943 4300

Fax: +41 (0)44 943 4398

[sales@zelana.co.uk](mailto:sales@zelana.co.uk)

**Customer business center  
Americas**

Honeywell Analytics Distribution, Inc.

400 Sawgrass Corporate Pkwy

Suite 100

Sunrise, FL 33325

USA

Tel: +1 954 514 2700

Toll free: +1 800 538 0363

Fax: +1 954 514 2784

[sales@zelana.com](mailto:sales@zelana.com)

[www.honeywell.com](http://www.honeywell.com)

Issue 2 12/2005  
H\_MAN0363.PM6\_V1  
00705M5002

© 2005 Honeywell Analytics

The Honeywell logo is displayed in a bold, red, sans-serif font.