

INSTRUCTION AND INSTALLATION MANUAL

EC-F2-EXP EXPLOSION PROOF SENSOR FOR AMMONIA

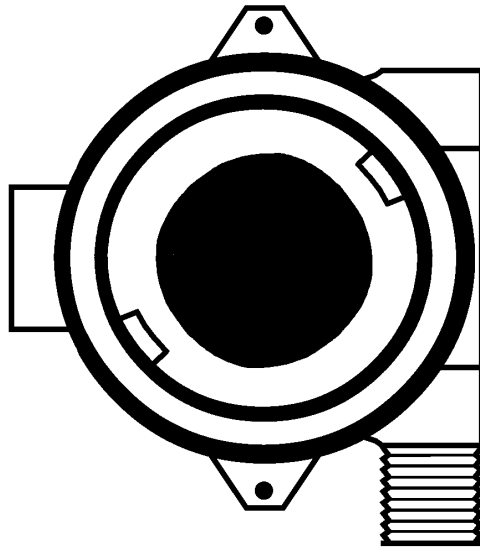

Model EC-F2-NH₃-EXP



Manning[™]
Systems, Inc.

11511 West 83rd Terrace
Lenexa, Kansas 66214
ph. 913.894.1185
fax 913.894.1296

CONTENTS



<u>Section</u>	<u>Title</u>	<u>Page</u>	<u>Serial Number</u> _____
1	Sensor Description	2	
2	Installation	3	
3	Operation	5	
4	Warranty	7	

1 SENSOR DESCRIPTION



A Introduction

This manual has been prepared to help in the use and installation of the Manning Systems' Model EC-F2-NH₃-EXP(Electrochemical-Ammonia-Explosion Proof) Sensor. This manual will convey the operating principles of the sensor, ensure proper installation, and demonstrate start-up and routine maintenance procedures for the sensor.

This manual must be carefully followed by all individuals who have or will have the responsibility for using or servicing the sensor. Warranties made by Manning Systems, Inc. with respect to this equipment will be voided if the equipment is not used and serviced in accordance with the instructions in this manual. If in doubt about a procedure, please contact Manning Systems, Inc. before proceeding.

B System Description

The Manning Systems' EC-F2 Sensor is a three-wire, 4/20 mA sensor for ammonia available in ranges of 0-100 ppm, 0-200 ppm, 0-250 ppm, and 0-500 ppm.

The unit exhibits excellent accuracy and precision, with negligible response to common interference gases and dramatic changes in relative humidity. Reliable trip levels as low as 25 ppm can be expected with the 0-100 ppm sensor. The unit exhibits extremely high reliability with no moving parts.

Monitoring equipment must be configured to indicate a fault if the signal is less than 1.5 mA. All signals over 20 mA must be considered a high gas concentration.

System Specifications:

Electrical Power: 24 Volts DC regulated, 30 mA.

Output: Linear 4/20 mA output into a load resistor of 250 ohm maximum.

Cable Recommendation: Three-conductor, 18 AWG, stranded, shielded cable with drain wire all enclosed in a vinyl jacket (Belden #8770 or equivalent).

Cable Length to Sensor: 1,500 feet maximum.

Unit Enclosure:

Explosion Proof

Class I, Group B, C, D

Class II, Group E, F, G

Class III, Nema 4

Sensor Specifications:

Type: Ammonia-selective electrochemical gas sensor/transmitter Model EC-F2-NH₃

Method of Detection: Electrochemical.

Ranges Available:

0-100 ppm

0-200 ppm

0-250 ppm

0-500 ppm

Accuracy: +/- 3% of full scale.

Humidity: 5-95% RH (non-condensing). Modifications are available for more severe conditions.

Operating Ambient Temperature range: -15° F to 120° F.

Storage Temperature: -40° F to +70° F. Keep sensor as cool as possible during long-term storage to extend the life of the cell.

Gas Sampling: Diffusion.

Weight: 3 pounds.

Dimensions: 6 1/4" high, 5 1/4" wide and 8" deep.



A Locating the EC-F2 Sensor

Because each sensor represents a point measurement, **it is very important that the sensor be located properly.** Figure 1 presents mounting dimensions for the EC-F2 Explosion-Proof ammonia sensor.

One of the most important considerations when installing EC sensors is that they must be easily accessible for calibration and maintenance. As a general rule, locate sensors no closer than 3 feet from walls or 1 foot from the ceiling.

If the primary application is **personnel protection** (representative concentration reading that an employee would be exposed to), mount the sensor at a height that would be in the breathing zone of the employees. It would typically be about five feet off the ground, which also allows easy access.

If the primary application is the fastest possible leak detection, mount the sensor near the potential leak sources. In the case of ammonia, this is usually near the ceiling as ammonia vapor is lighter than air. In doing this, be aware that the indicated concentration will not be representative of personnel exposure and easy access for the required calibration and maintenance could be compromised.

No matter where the sensor is mounted, it must be easily accessible.

General Mounting Considerations:

- Must be easily accessible for calibration and maintenance.
- Mount the sensor close to the potential leak source.
- If personnel protection is the primary application, mount in the “breathing zone.”
- Protect sensor from water, excessive humidity, and wash-down.
- Take air movement and ventilation patterns into account.
- To prevent electrical interference, keep sensor and wire runs away from mercury vapor lights, variable speed drives, and radio repeaters.

- Protect sensor from physical damage (fork lifts, etc.).

- If mounting sensor outdoors, consider prevailing wind direction and proximity to the most likely source of leaks. Protect the sensor from sun and rain as much as possible.

- For highly critical locations more than one sensor should be installed in each room.

- Always mount with sensor pointing down

Engine Rooms: The EC sensor should be mounted in a cool part of the room, if possible. Keep the sensor away from hot air exhausting from electric

motors or other machinery. Usually the best location is four or five feet above the floor in a location where the room exhaust fan will move air across the sensor from the potential leak source.

Refrigerated Areas: The EC-F2-NH₃-EXP is not designed to be used in refrigerated spaces. Other enclosures are necessary. Contact Manning Systems for more information.

Other Locations: When mounting EC sensors in locations such as roof top air units, duct-work, attic spaces, makeup air intakes, etc., contact Manning Systems for application assistance and recommendations.

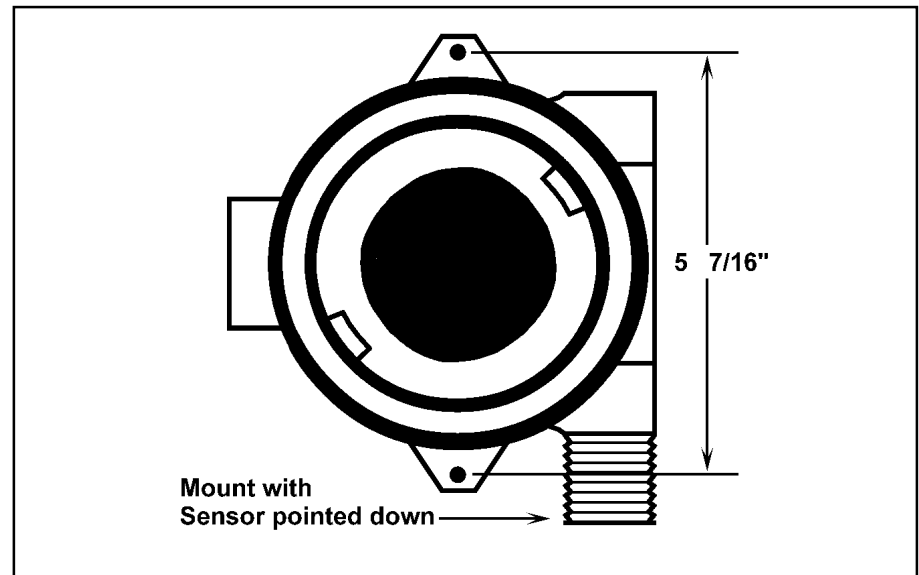

Figure 1: Mounting dimensions for the EC-F2-EXP Sensor



B Wiring

Figure 2 presents wiring information for the EC-F2 sensor.

Electrical wiring must comply with all applicable codes. Plant equipment that may be involved and operating conditions should be discussed with local operating personnel to determine if any special needs should be taken into account.

Almost all start-up problems are due to improper wiring or monitor configuration. Please follow these guidelines carefully.

Always use three conductor, insulated, stranded, shielded copper cable. Use only three conductor cable, not two cables of two conductor wire.

Do not pull sensor wiring with AC power cables. This will cause electrical interference. Be sure there are no breaks or splices in sensor wiring runs. If cable runs cannot be made without a splice, all connections must be soldered. Soldering should be done using a rosin flux to tie the connecting ends of sensor wires to ensure a positive and long-lasting contact.

Ground the shield at the main control panel. Connect the shield wire in the sensor terminal block labeled *SHLD*. Tape all exposed shield wire at the sensor to insulate it from the enclosure.

All penetrations into a refrigerated room should be sealed to prevent condensate from forming in the conduit and dripping into the sensor enclosure. Silicone should not be used near the sensor, because silicone can damage the sensor.

Make drip loops for cables going into sensor housing.

Caution: Use of this sensor in a hazardous location requires special care in the sealing of external conduit entries. Explosion proof conduit seals must be used as required by local fire and building codes. Failure to follow all codes and install adequate seals can result in an explosion hazard.

Mount sensor enclosures through the flange holes as shown in Figure 1, and always mount with sensor pointing down.

Electrical Power: 24 VDC regulated, 30 mA.

Output: Sensor provides a linear 4-20 mA output. Monitoring equipment

may have a maximum input impedance of 250 ohms.

Cable Recommendation: No. 18/3 shielded cable (Belden #8770 or equivalent). Length of cable to sensor should be no greater than 1,500 feet. Use only the existing hole for connections to the sensor.

Monitoring: The EC-F2 Ammonia Sensor may be monitored by the Manning Systems' Model 20, GM-1, GM-JR, GM-10, or other appropriately configured system. Monitoring equipment must be configured to indicate a fault if the signal is below 1.5 mA. All signals over 20 mA must be considered a high gas concentration.

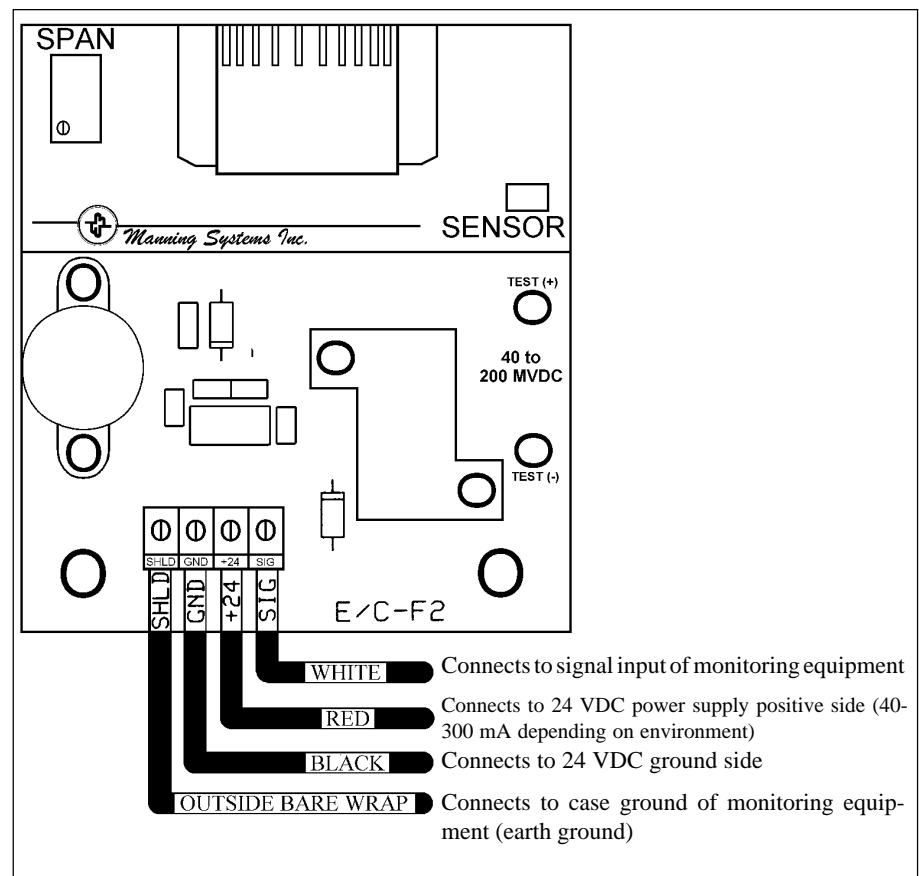

Figure 2: Wiring diagram for the EC-F2 Sensor



A Start-Up Procedures

Before applying power, make a final check of all wiring for continuity, shorts, grounds, etc. (see Figure 3, Note 5). It is usually best to disconnect external alarms and other equipment from the sensor until the initial start-up procedures are completed.

After power-up, allow 24 hours for the system to stabilize before testing the sensors. Because sensors are normally located at a distance from the main unit, the test time required and accuracy of the response checks will be improved if two people perform the start-up procedures and use radio contact.

Start-Up Test:

- 1) One person exposes each sensor to a small amount of the gas that is being monitored.
- 2) The second person stays at the control unit to determine that each sensor, when exposed to the gas fumes, is connected to the proper input and responds, causing appropriate alarm functions.

B Calibration

The EC-F2 Sensor comes factory calibrated and should require minimal adjustments after installation. There are two pots on the preamp that are used for calibrations.

Zero Calibration: After the unit is installed and has been powered up for a minimum of 24 hours, the unit should be zero calibrated by the following:

- Be sure the unit is in clean air.
- Adjust the zero pot until the sensor outputs 4.0 mA (40 mV from Test [-] to Test [+]) (see Figure 3, Note 2 and 4).

Span Calibration: The unit is factory calibrated and normally does not need to be spanned upon initial installation. DO NOT ADJUST THE SPAN POT WITHOUT

CERTIFIED CALIBRATION GAS! If span adjustment is required, the following procedure will span the unit:

- Perform zero adjustment before spanning.
- Apply span gas at 0.8 L/min (span gas must be in air, not nitrogen or other carrier).
- After span gas has been on sensor for two minutes, adjust the span pot until the correct output is achieved (see Figure 3, Note 1).

Calibration kits are available from Manning Systems.

C Troubleshooting

If the sensor output is 0 mA: First, verify +24 VDC at the sensor terminal block (see Figure 3, Note 5).

Second, check voltage between Test (-) and Test (+) (see Figure 3, Note 4). Voltage should be in the range of 40 mV to 200 mV corresponding to an actual current flow of 4 to 20 mA. If this voltage is 0 mV, the signal has no path to ground. Check monitoring equipment connections

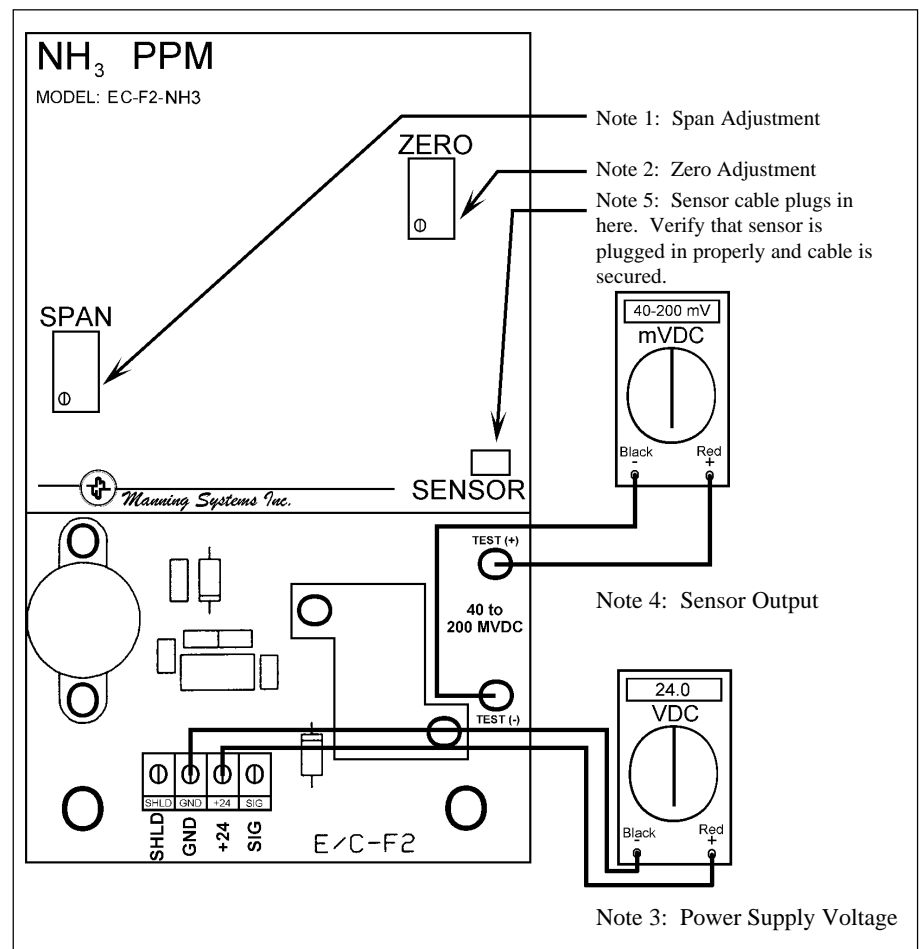

Figure 3: Checking sensor output, power supply voltage, and zero and span adjustments to the EC-F2 Sensor



and configuration. Input impedance must be 250 ohms or less.

Electrical Interference: This sensor has been designed to be highly resistant to EMI/RFI using multiple stages of filtering and protection. However, in extreme environments, some noise pickup can occur directly through the sensor. Ensure that the bare shield wire of the instrument cable is connected to the terminal block marked *SHLD* at the sensor (not touching the metal enclosure) and properly grounded at the readout unit.

Interference Gases: The EC-F2-NH₃ is designed to be quite specific to ammonia. However, some other gases can affect the reading. Phosphene, methyl mercaptan, and hydrogen can give a slight upscale indication. Bromine, ozone, fluorine, chlorine, and nitrogen dioxide can give a slight down-scale indication. Contact Manning Systems if any of these gases are present in your application.

D Maintenance

For proper operation it is essential that the test and calibration schedule be adhered to. Manning Systems recom-

mends the following maintenance schedule:

- Response test once per month. Expose sensor to ammonia/water solution to verify proper sensor response and alarm functions. Test more frequently in highly critical applications.

- Calibration should be performed with certified calibration gas every six months. Calibration kits are available from Manning Systems.

- All tests and calibrations must be logged

Sensor Life: These electrochemical cells are extremely reliable, but several things can cause the cell chemicals to become depleted including:

- a period of time,
- exposure to high temperatures,
- exposure to varying concentrations of the target gas,
- exposure to high moisture for extended periods without proper sensor enclosure.

When the cell becomes depleted, the unit will give no indication of failure other than that the sensor will not respond. For this reason it is **absolutely essential that these units be exercised with a gas sample on a regular and timely basis.**

Typical sensor life in a non-refrigerated area will be 12 months or less. Exposure to high levels of ammonia will shorten these times. In addition to timely response checks, a preventative maintenance program of periodic cell replacement should be implemented.

When the cell becomes depleted, a replacement cell can be obtained from Manning Systems. Simply unplug the ribbon cable from the pins labeled *Sensor*, unscrew the stainless steel housed cell from the bottom of the sensor enclosure, discard the old cell and replace it with a new one. When ordering a new cell, specify that it is in an explosion proof housing.

The sensor should be calibrated after a 24 hour warm-up period.

E Replacement Parts

For replacement parts, contact Manning Systems. Be sure to give serial number of unit and model number.



Limited Warranty

1. Limited Warranty. Manning Systems, Inc. (“Manning”) warrants to the original purchaser and/or ultimate customer (“Purchaser”) of Manning’s Products (“Product”) that if any part thereof proves to be defective in material or workmanship within eighteen (18) months of the date of shipment by Manning or twelve (12) months from the date of first use by the purchaser, whichever comes first, such defective part will be repaired or replaced, free of charge, at Manning’s discretion if shipped prepaid to Manning at 11511 W. 83rd Terrace, Lenexa, Kansas 66214, in a package equal to or in the original container. The Product will be returned freight prepaid and repaired or replaced if it is determined by Manning that the part failed due to defective materials or workmanship. The repair or replacement of any such defective part shall be Manning’s sole and exclusive responsibility and liability under this limited warranty.

2. Exclusions.

A. If gas sensors are part of the Product, the gas sensor is covered by a twelve (12) month limited warranty of the manufacturer.

B. If gas sensors are covered by this limited warranty, the gas sensor is subject to inspection by Manning for extended

exposure to excessive gas concentrations if a claim by the Purchaser is made under this limited warranty. Should such inspection indicate that the gas sensor has been expended rather than failed prematurely, this limited warranty shall not apply to the Product.

C. This limited warranty does not cover consumable items, such as batteries, or items subject to wear or periodic replacement, including lamps, fuses, valves, vanes, sensor elements, cartridges, or filter elements.

3. Warranty Limitation and Exclusion.

Manning will have no further obligation under this limited warranty. All warranty obligations of Manning are extinguishable if the Product has been subject to abuse, misuse, negligence, or accident or if the Purchaser fails to perform any of the duties set forth in this limited warranty or if the Product has not been operated in accordance with instructions, or if the Product serial number has been removed or altered.

4. Disclaimer of Unstated Warranties.

THE WARRANTY PRINTED ABOVE IS THE ONLY WARRANTY APPLICABLE TO THIS PURCHASE. ALL OTHER WARRANTIES, EX-

PRESS OR IMPLIED, INCLUDING, BUT NOT LIMITED TO, THE IMPLIED WARRANTIES OF MERCHANTABILITY OR FITNESS FOR A PARTICULAR PURPOSE ARE HEREBY DISCLAIMED.

5. Limitation of Liability. IT IS UNDERSTOOD AND AGREED THAT MANNING’S LIABILITY, WHETHER IN CONTRACT, IN TORT, UNDER ANY WARRANTY, IN NEGLIGENCE OR OTHERWISE SHALL NOT EXCEED THE AMOUNT OF THE PURCHASE PRICE PAID BY THE PURCHASER FOR THE PRODUCT AND UNDER NO CIRCUMSTANCES SHALL MANNING BE LIABLE FOR SPECIAL, INDIRECT, OR CONSEQUENTIAL DAMAGES. THE PRICE STATED FOR THE PRODUCT IS A CONSIDERATION LIMITING MANNING’S LIABILITY. NO ACTION, REGARDLESS OF FORM, ARISING OUT OF THE TRANSACTIONS UNDER THIS WARRANTY MAY BE BROUGHT BY THE PURCHASER MORE THAN ONE YEAR AFTER THE CAUSE OF ACTION HAS OCCURRED.

